



# Dimensioning Chapter



# TOPICS

- Introduction
- Dimensioning components
- Dimensioning object' s features
- Placement of dimensions.

# ***Introduction***



# ENGINEERING DESIGN

PROCESS

RESULT

TRANSFERRED  
INFORMATION

Design  
a part

Sketches  
of ideas

↓  
Create  
drawings

Multiview  
Drawing

Shape

Dimensioning

1. Size, Location

2. Non-graphic information

↓  
Manufacture

# DEFINITION

***Dimensioning*** is the process of specifying part's information by using of **figures, symbols** and **notes**.

This information are such as:

1. **Sizes and locations of features**
2. **Material's type**
3. **Number required**
4. **Kind of surface finish**
5. **Manufacturing process**
6. **Size and geometric tolerances**

This course

# DIMENSIONING SYSTEM

This  
course

## 1. Metric system : ISO and JIS standards

Examples 32, 32.5, 32.55, 0.5 (*not .5*) etc.

## 2. Decimal-inch system

Examples 0.25 (*not .25*), 5.375 etc.

## 3. Fractional-inch system

Examples  $\frac{1}{4}$ ,  $5\frac{3}{8}$  etc.

# ***Dimensioning Components***



# DIMENSIONING COMPONENTS

- Extension lines
- Dimension lines  
*(with arrowheads)*
- Leader lines

Drawn with  
**4H** pencil

- Dimension figures
- Notes :
  - *local note*
  - *general note*

Lettered with  
**2H** pencil.

# EXTENSION LINES

indicate the location on the object's features that are dimensioned.

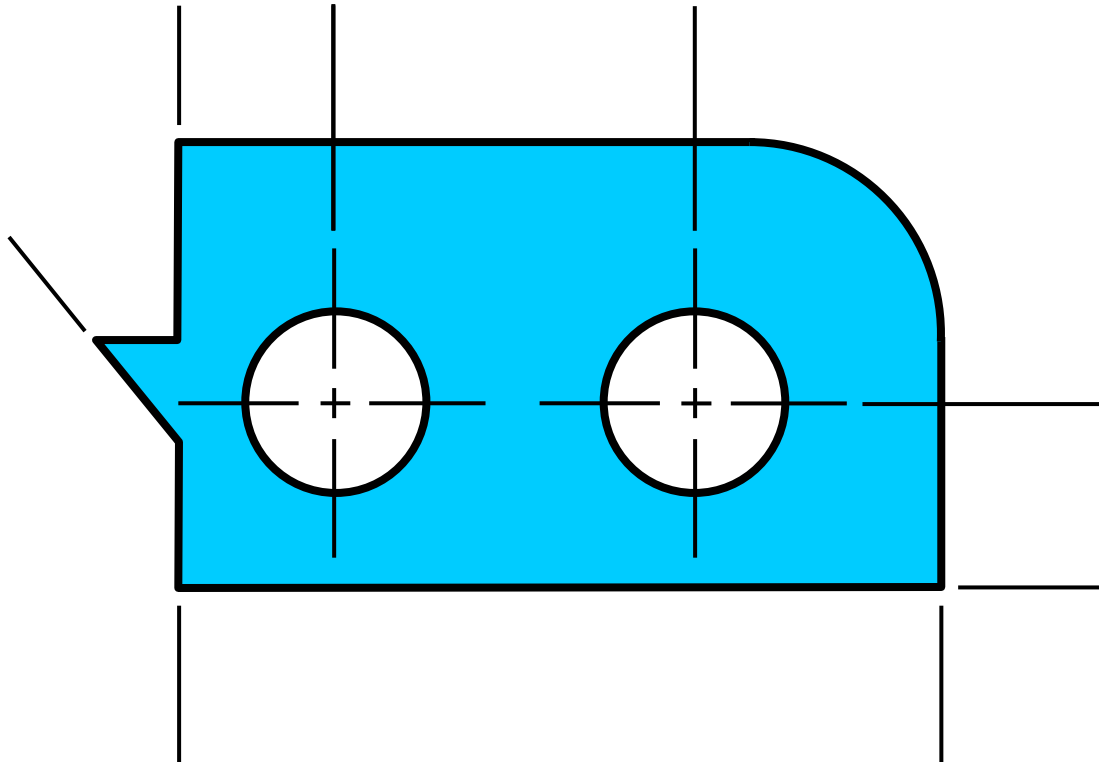

# DIMENSION LINES

indicate the direction and extent of a dimension, and inscribe *dimension figures*.

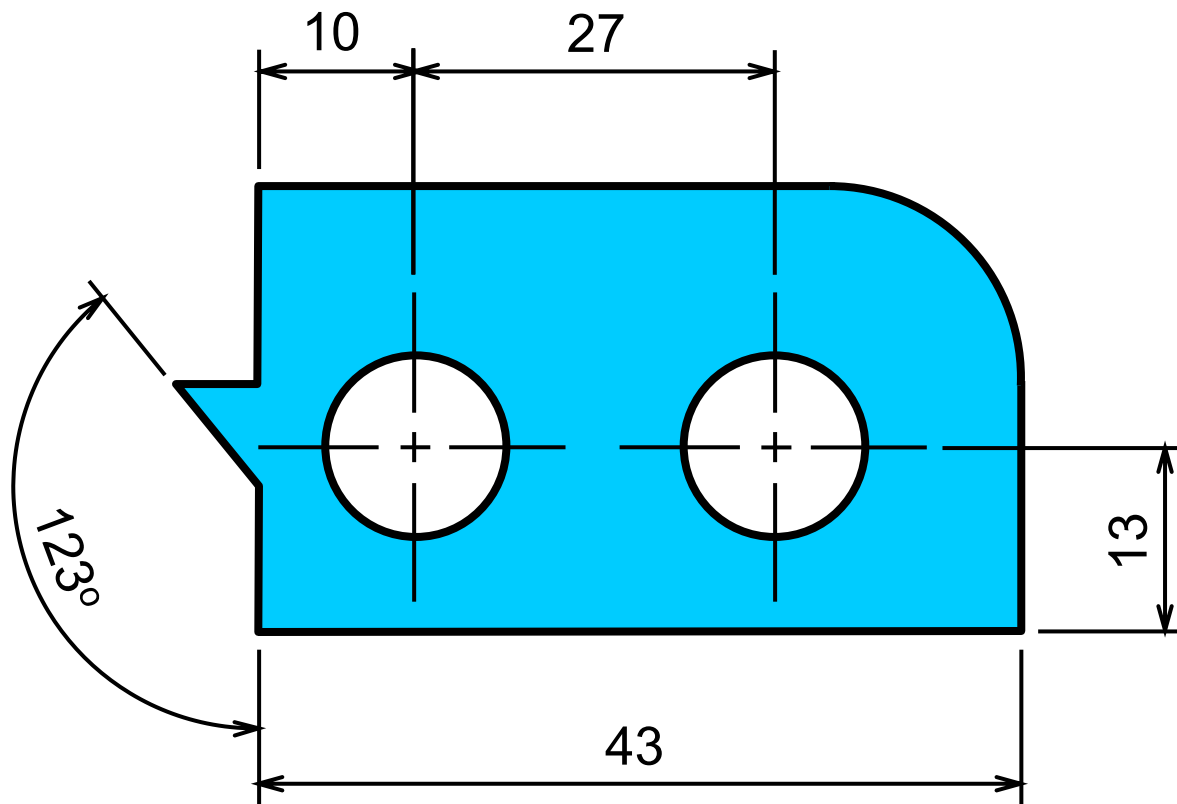

# LEADER LINES

indicate details of the feature with a *local* note.

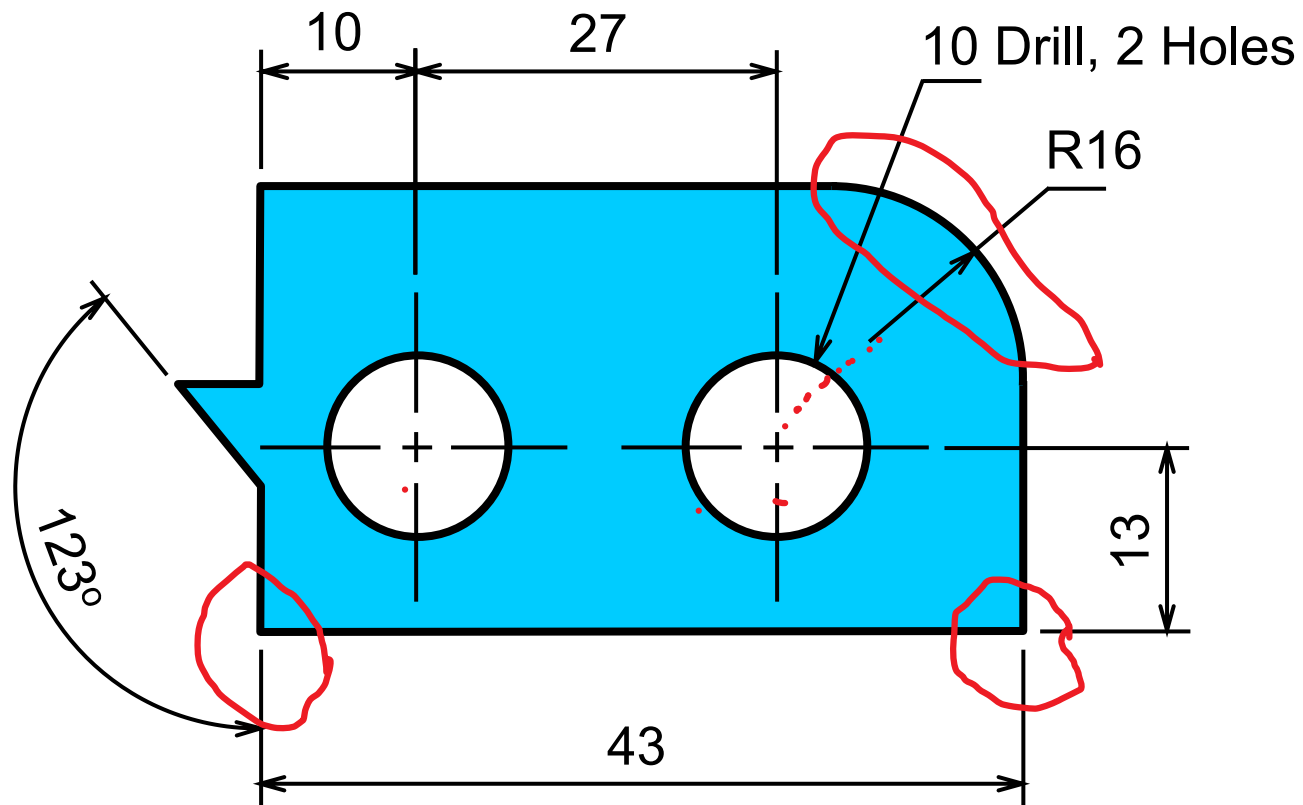

# ***Recommended Practices***



# EXTENSION LINES

- Leave a **visible gap** ( $\approx 1$  mm) from a view and start drawing an extension line.
- Extend the lines beyond the (last) extension line 1-2 mm.

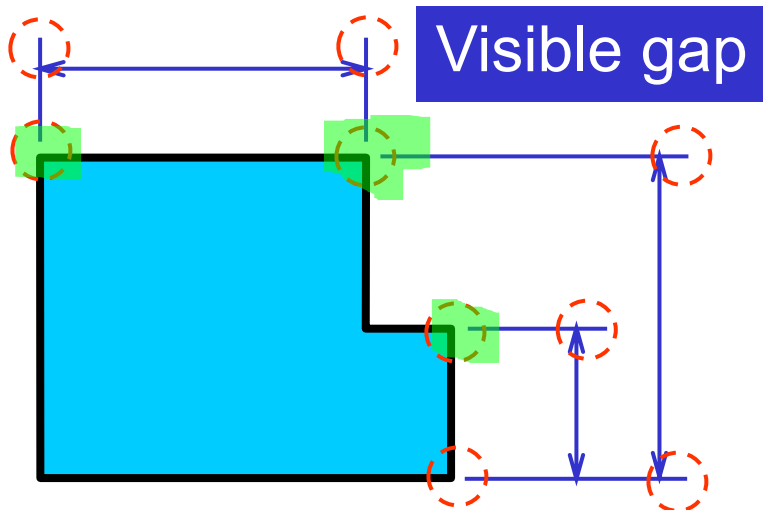

## COMMON MISTAKE

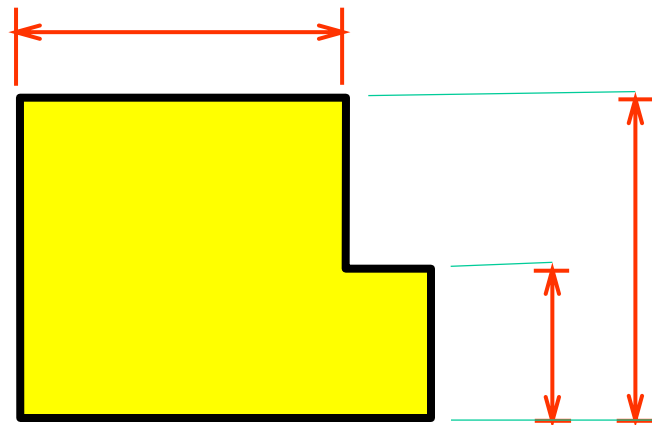

# EXTENSION LINES

- **Do not** break the lines as they cross object lines.

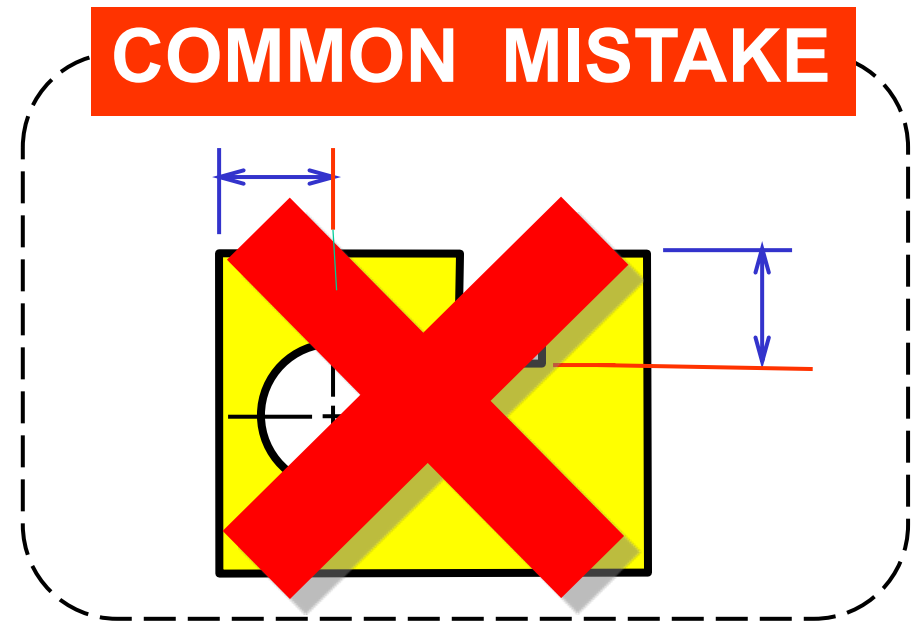
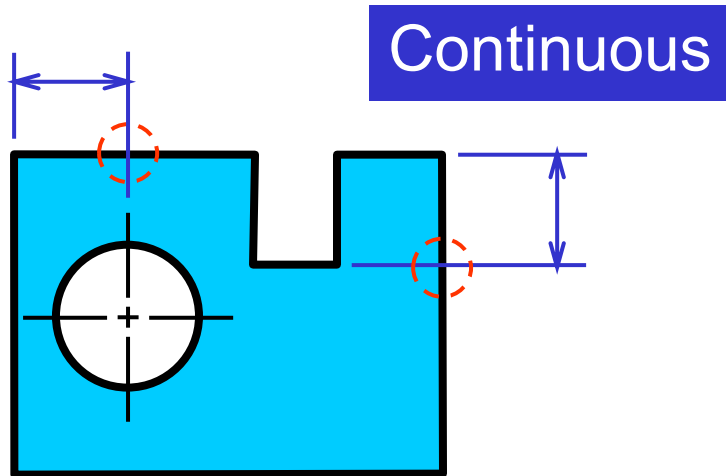

# DIMENSION LINES

- Dimension lines should **not** be spaced too close to each other and to the view.

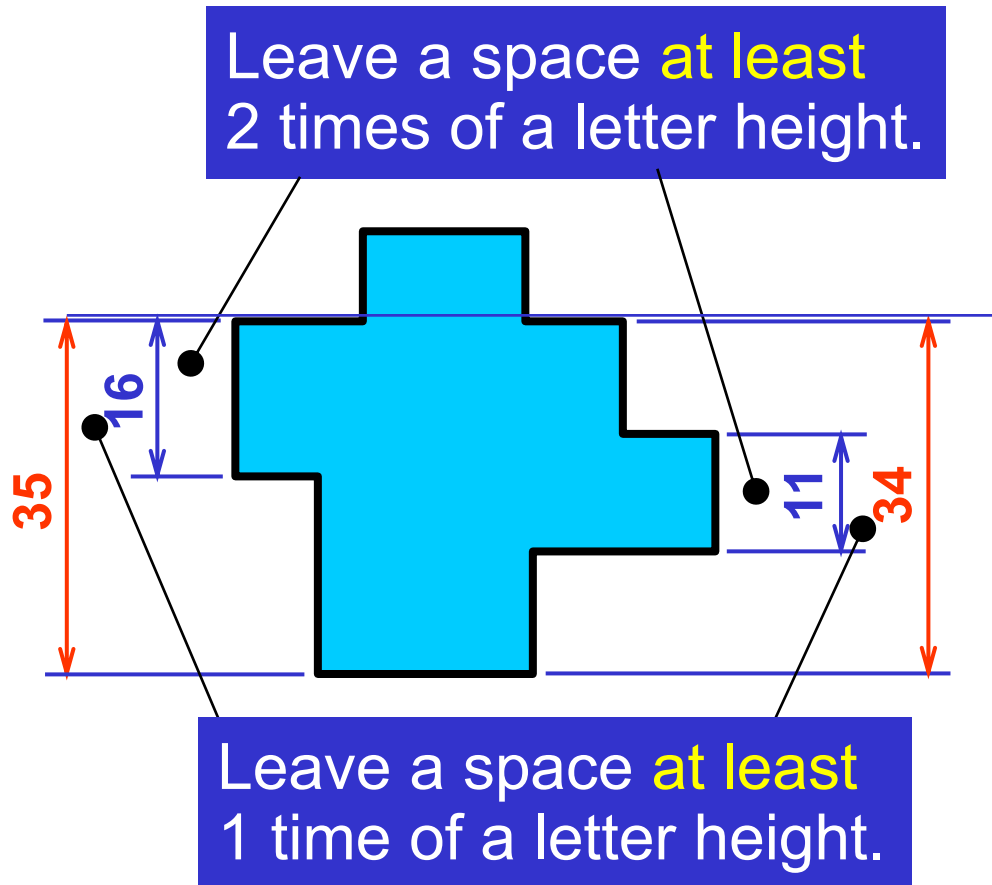

# DIMENSION FIGURES

- The height of figures is suggested to be 2.5~3 mm.
- Place the numbers at about 1 mm *above dimension line* and *between extension lines*.

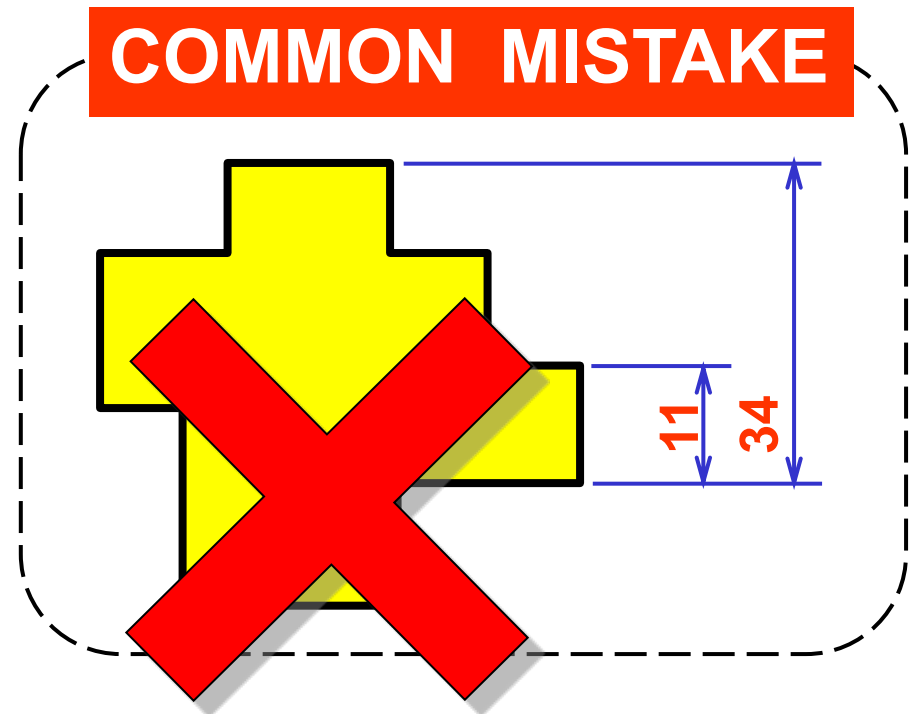
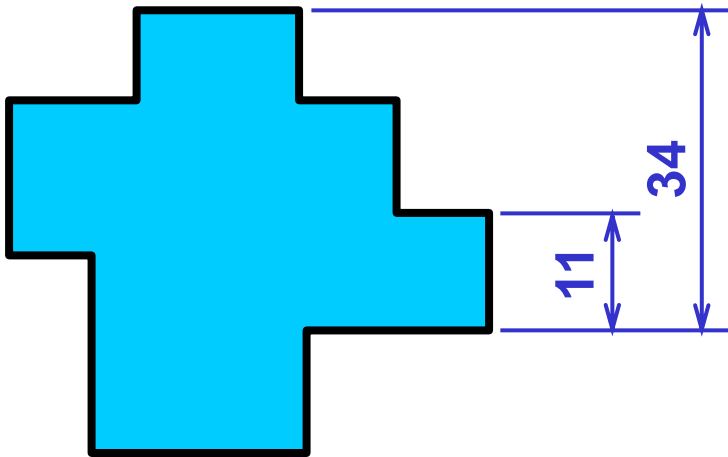

# DIMENSION FIGURES

- When there is **not** enough space for figure or arrows, put it **outside** either of the extension lines.

Not enough space  
for *figures*

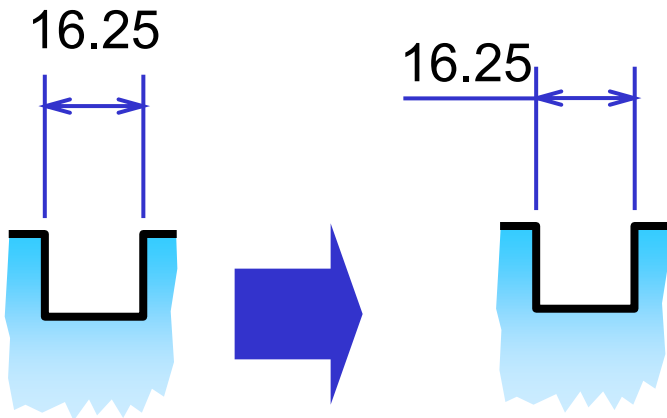

Not enough space  
for *arrows*

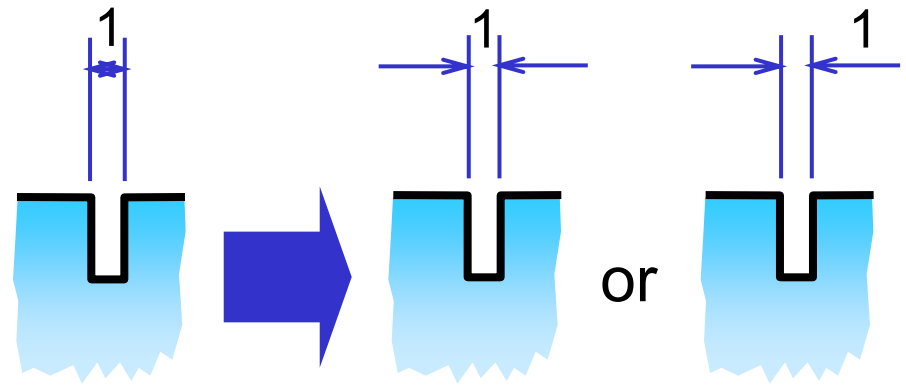

# DIMENSION FIGURES : UNITS

The JIS and ISO standards adopt the unit of

- **Length** dimension in **millimeters** **without** specifying a unit symbol “mm”.
- **Angular** dimension in **degree** with a symbol “°” place behind the figures (and if necessary **minutes** and **seconds** may be used together).

# DIMENSION FIGURES : ORIENTATION

## 1. Aligned method

The dimension figures are placed so that they are readable from the **bottom** and **right side** of the drawing.

## 2. Unidirectional method

The dimension figures are placed so that they can be read from the **bottom** of the drawing.

**Do not** use both system on the same drawing or on the same series of drawing (JIS Z8317)

**EXAMPLE :** Dimension of *length* using *aligned* method.

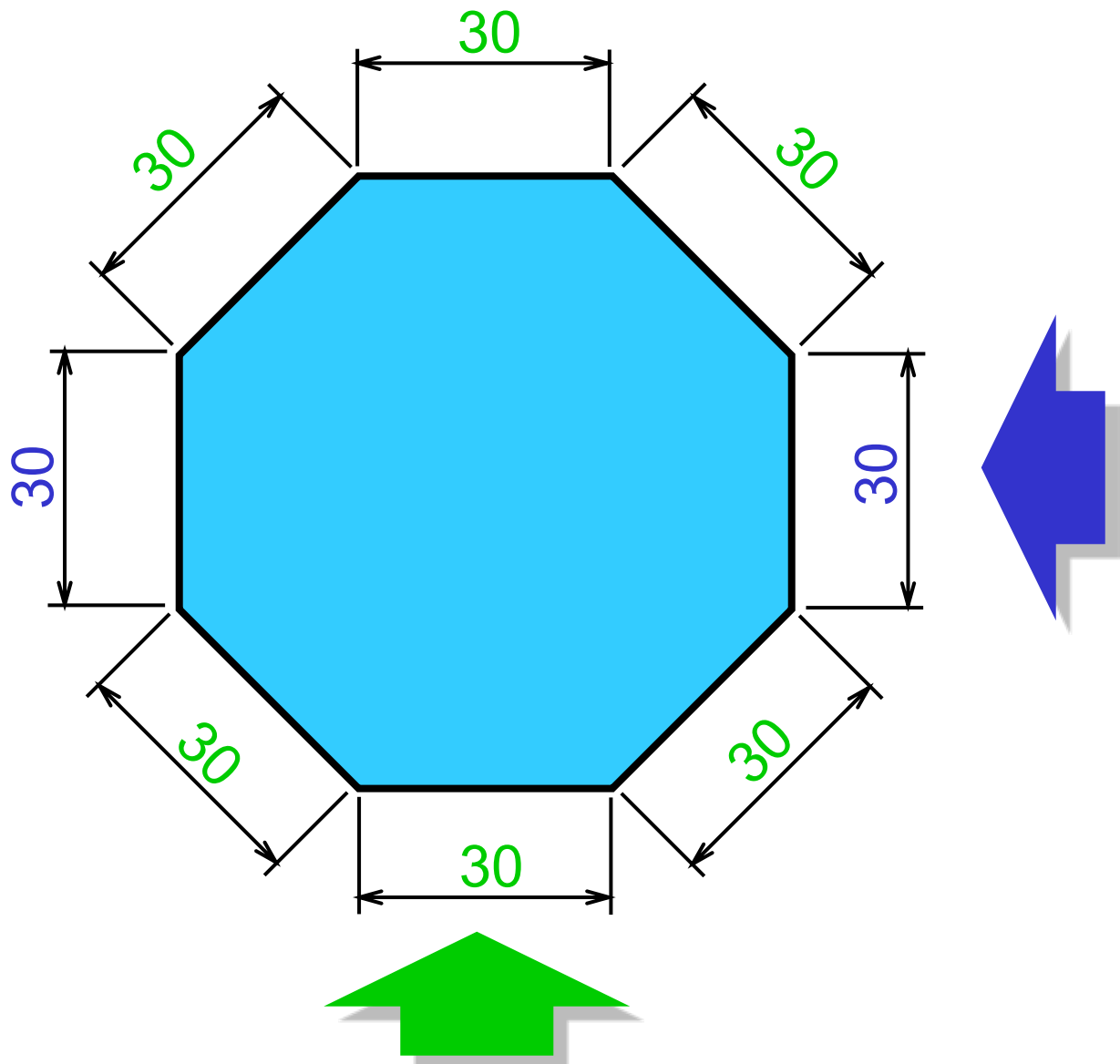

**EXAMPLE :** Dimension of *length* using *unidirectional* method.

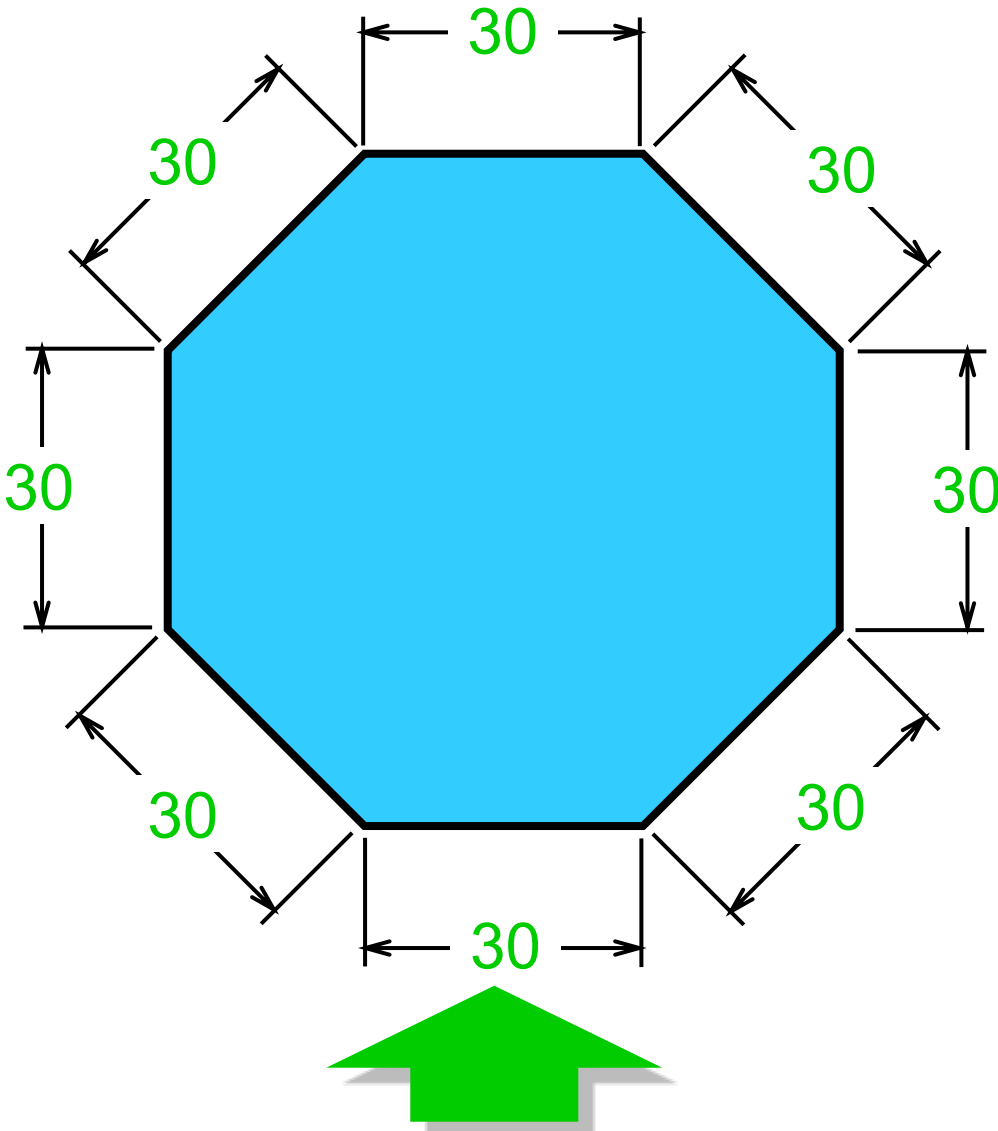

**EXAMPLE :** Dimension of *angle* using *aligned* method.

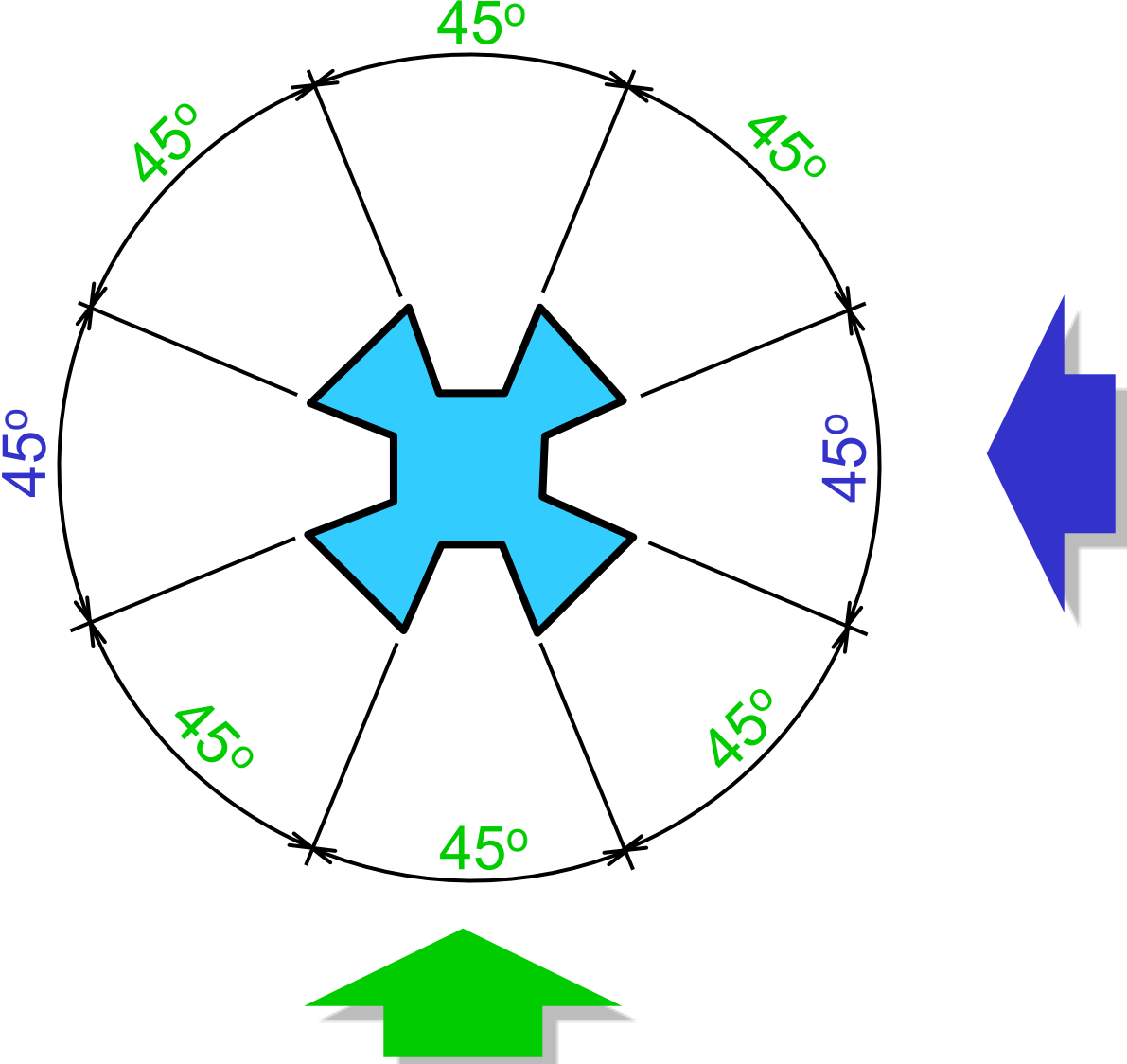

**EXAMPLE :** Dimension of *angle* using *unidirectional* method.

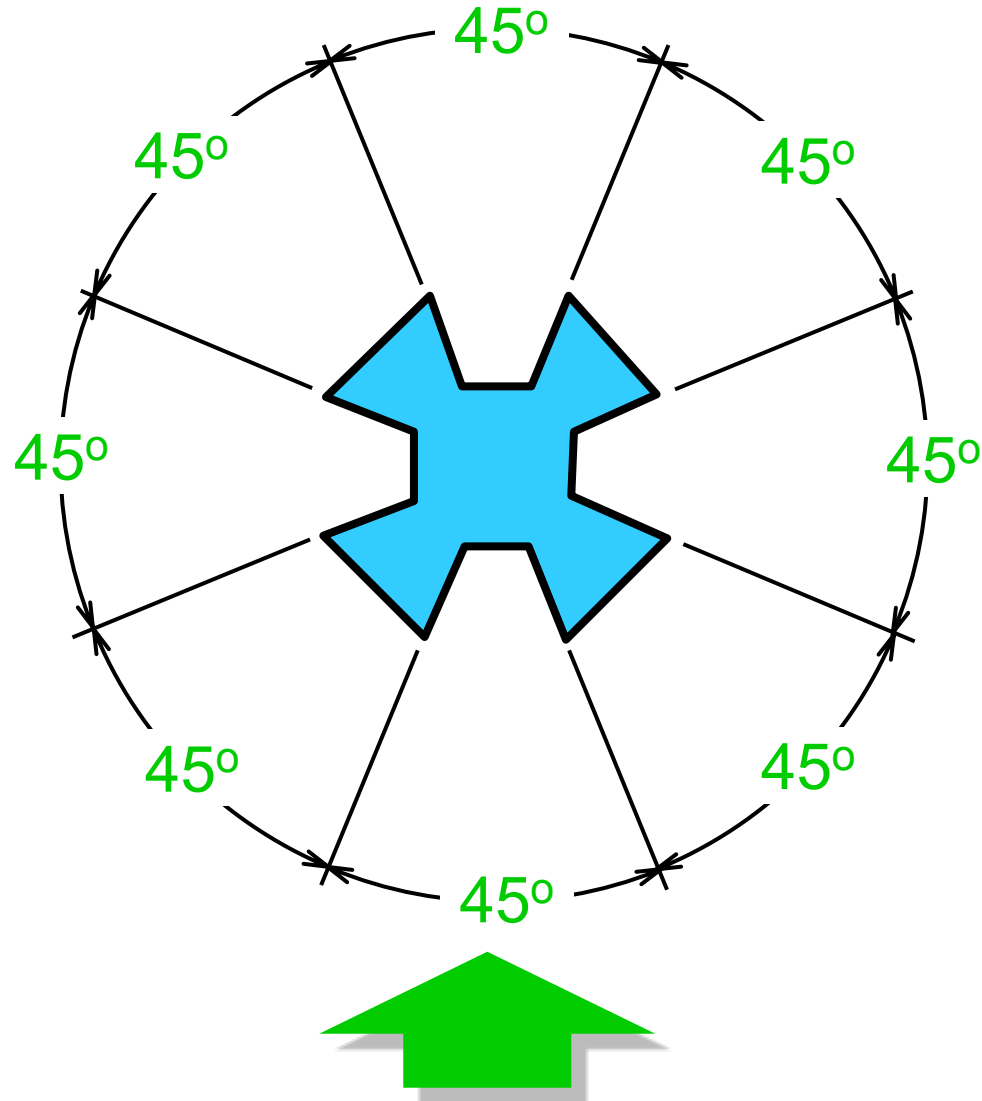

# LOCAL NOTES

- Place the notes **near** to the feature which they apply, and should be placed outside the view.
- Always read **horizontally**.

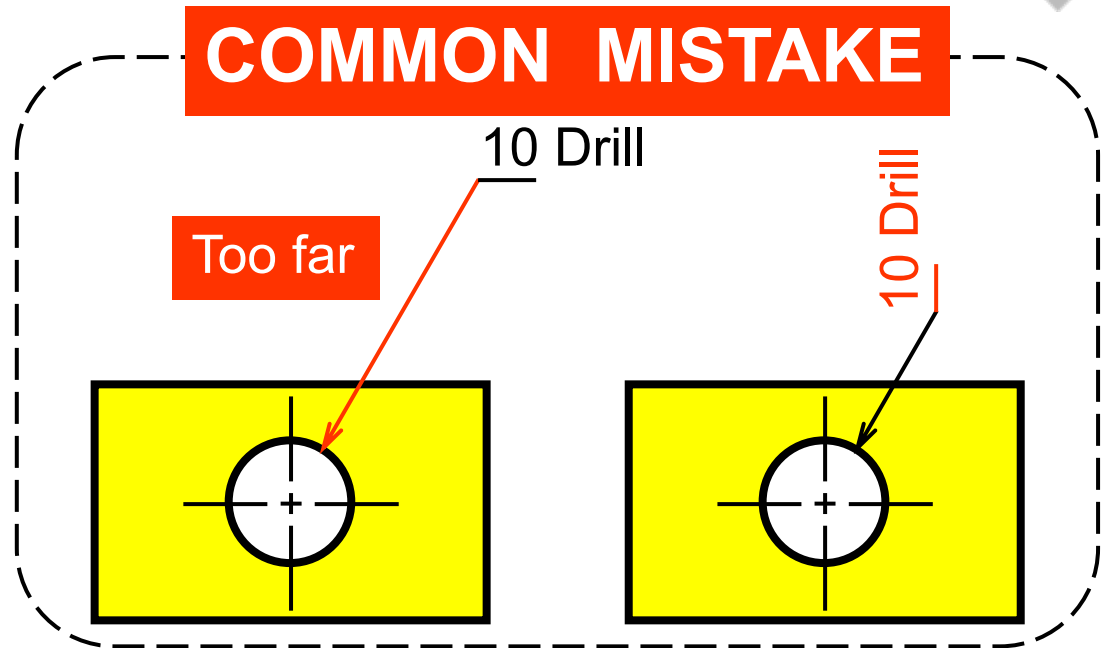
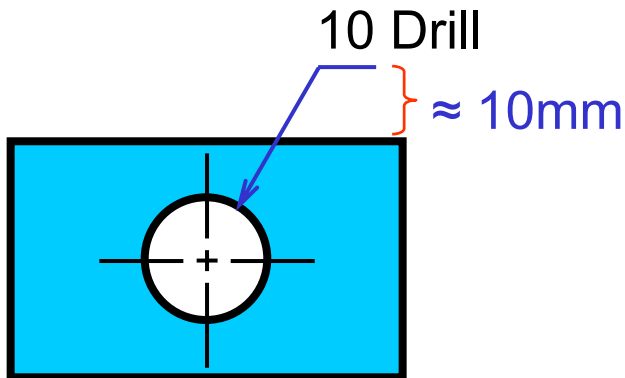

# ***Dimensioning Practices***



# THE BASIC CONCEPT

Dimensioning is accomplished by adding *size* and *location* information *necessary to manufacture* the object.

This information have to be

- Clear
- Complete
- Facilitate the
  - manufacturing method
  - measurement method

# EXAMPLE

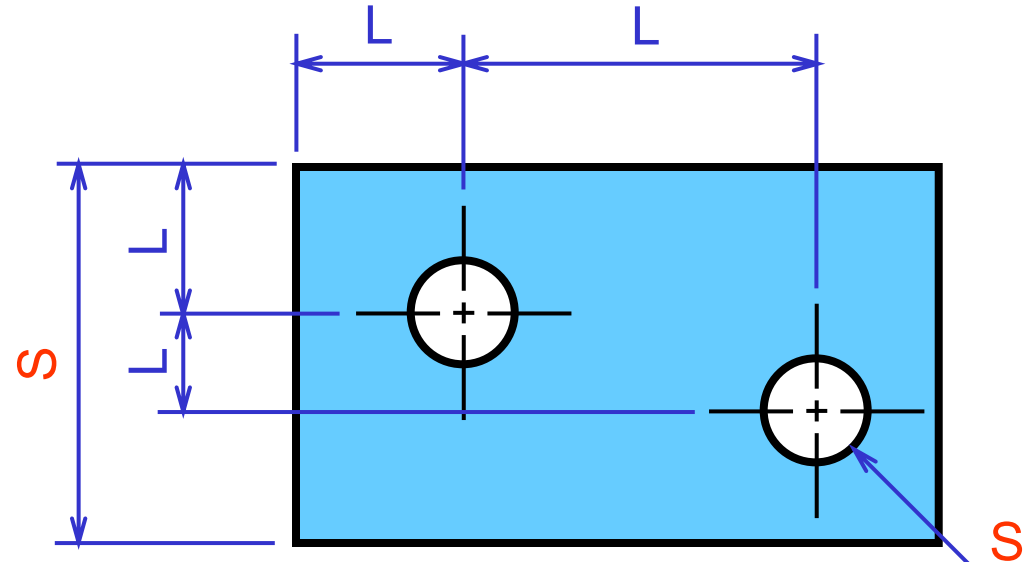
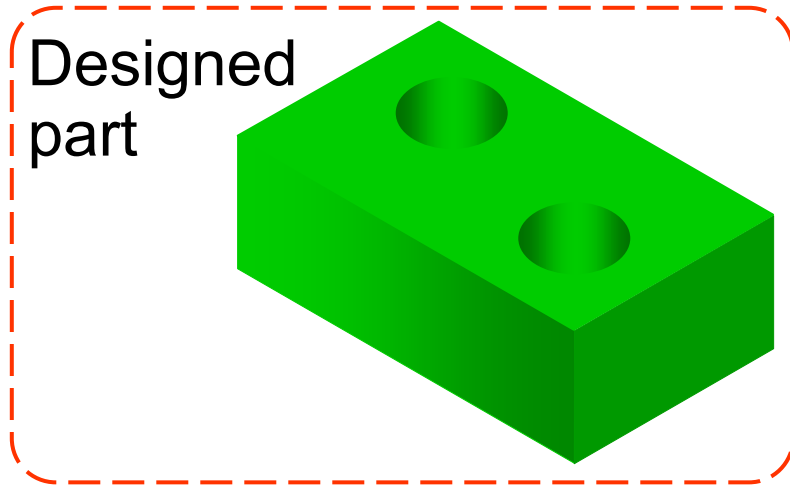

To manufacture this part we need to know...

1. **Width**, **depth** and **thickness** of the part.
2. **Diameter** and **depth** of the hole.
3. **Location** of the holes.

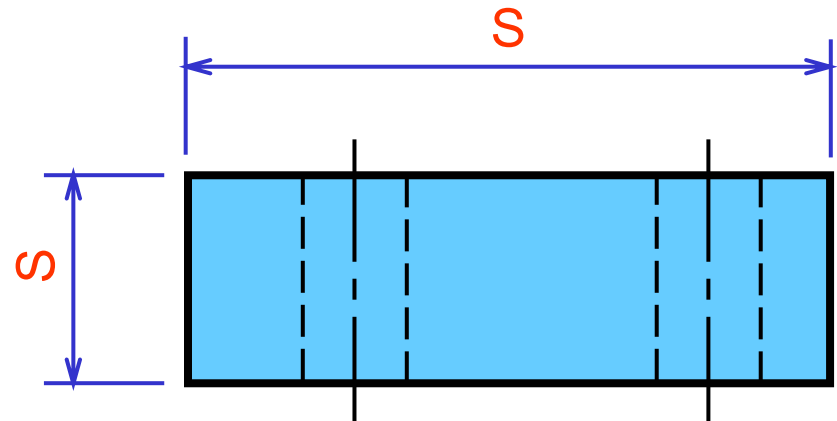

“S” denotes size dimension.  
“L” denotes location dimension.

# ANGLE

- To dimension an angle use **circular dimension line** having the center at the vertex of the angle.

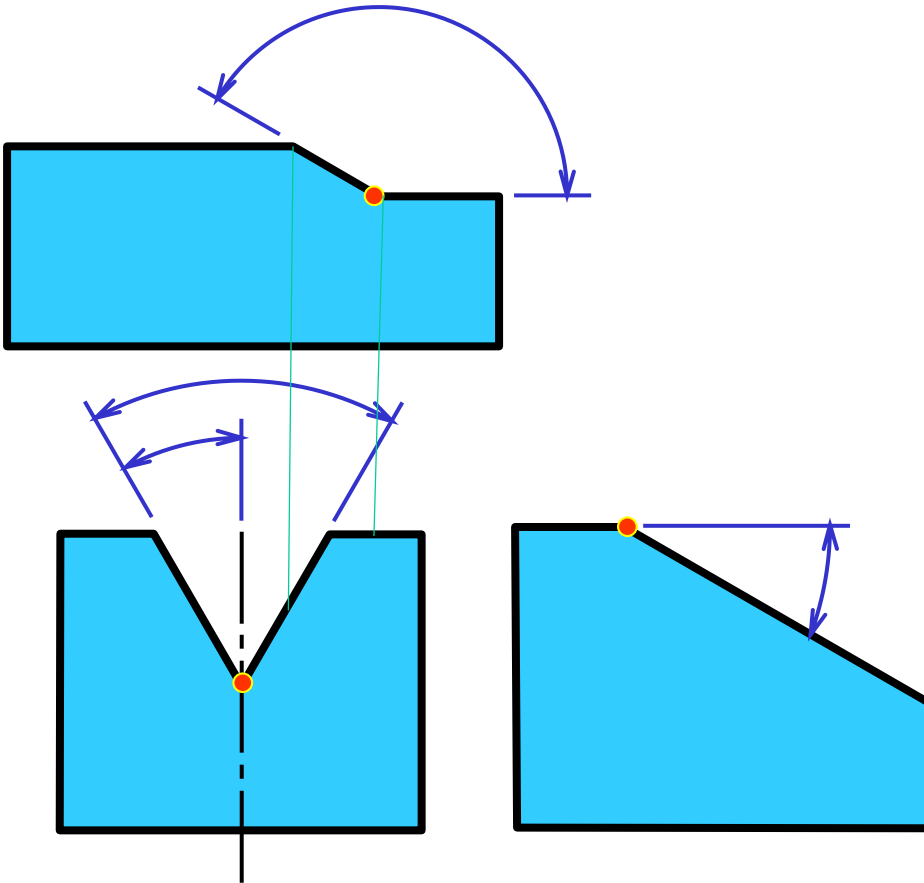

## COMMON MISTAKE

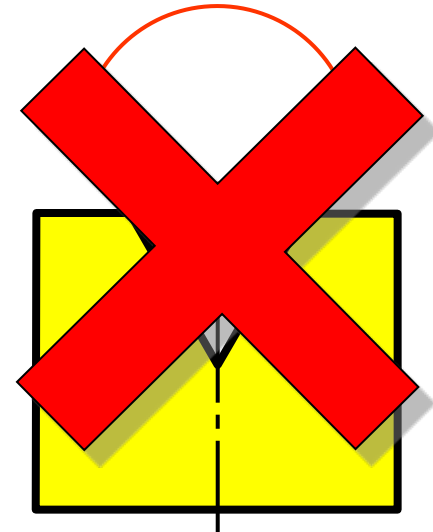

# ARC

- Arcs are dimensioned by giving the **radius**, in the views in which their true shapes appear.
- The letter “R” is **always** lettered before the figures to emphasize that this dimension is radius of an arc.

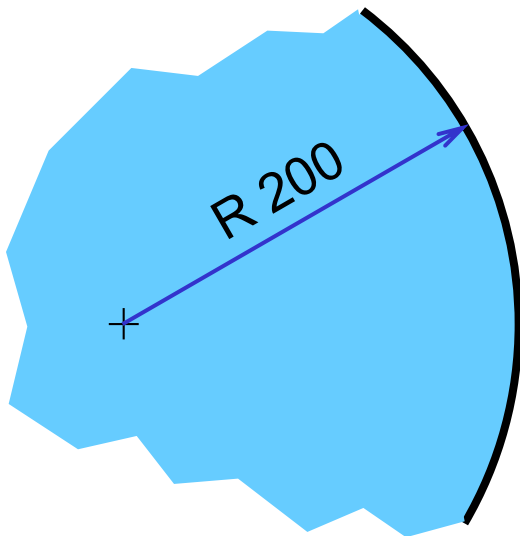

or

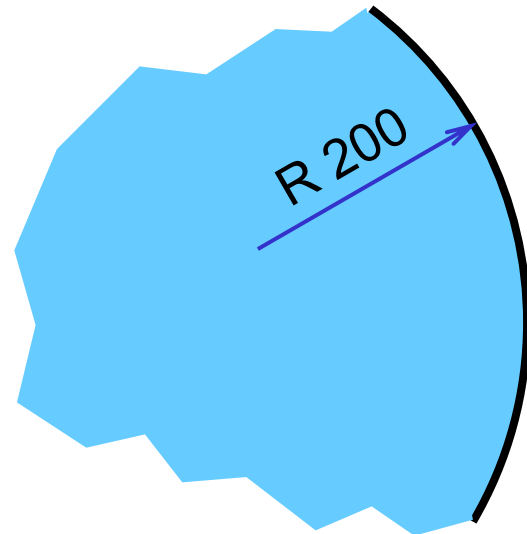

# ARC

- The dimension figure and the arrowhead **should be inside** the arc, where there is sufficient space.

Sufficient space  
for both.

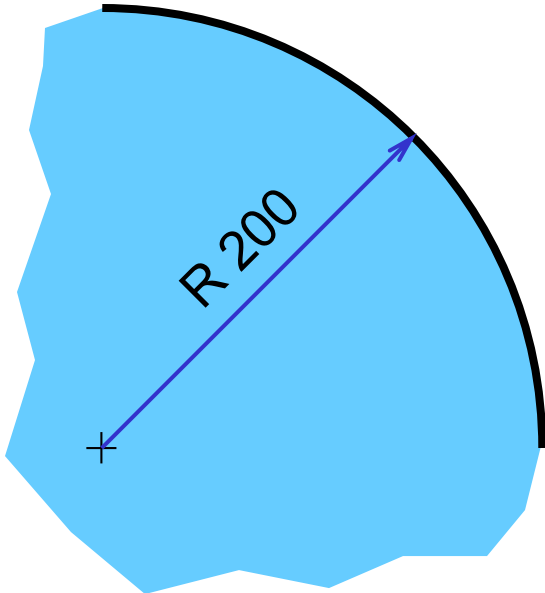

Sufficient space  
for arrowhead only.

Move figure outside

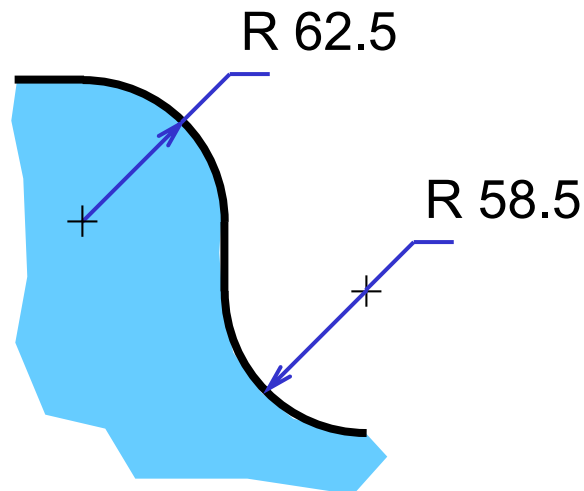

Insufficient space  
for both.

Move both figure  
and arrow outside

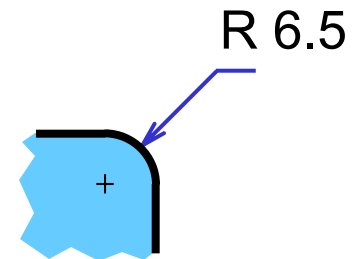

# ARC

- Leader line **must** be **radial** and **inclined** with an angle between 30 ~ 60 degs to the horizontal.

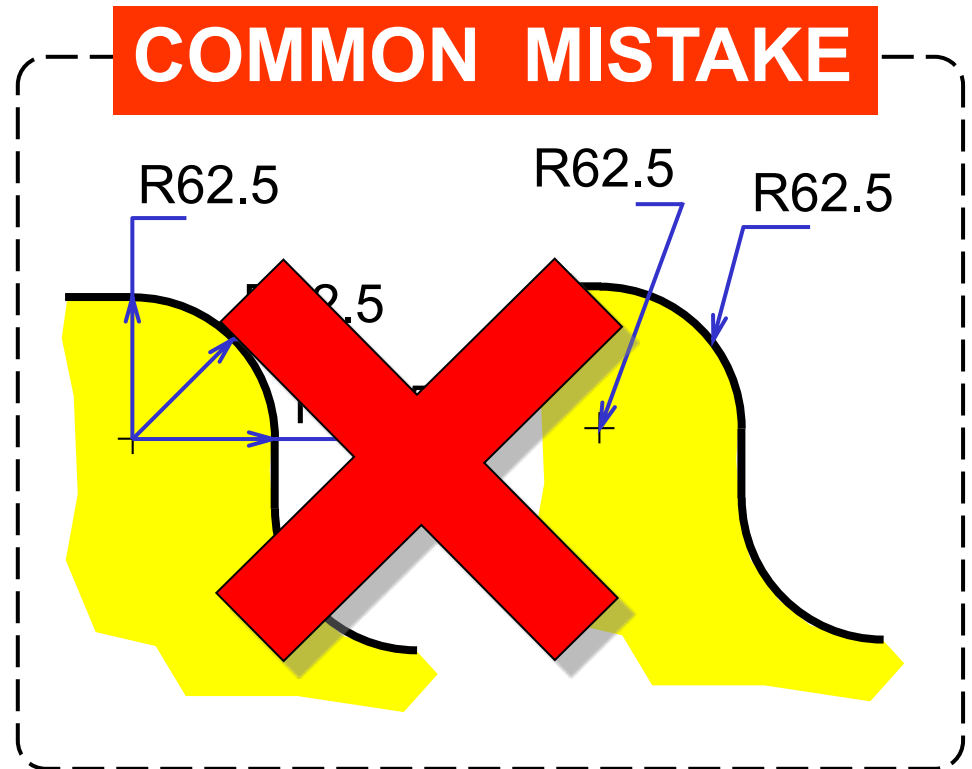
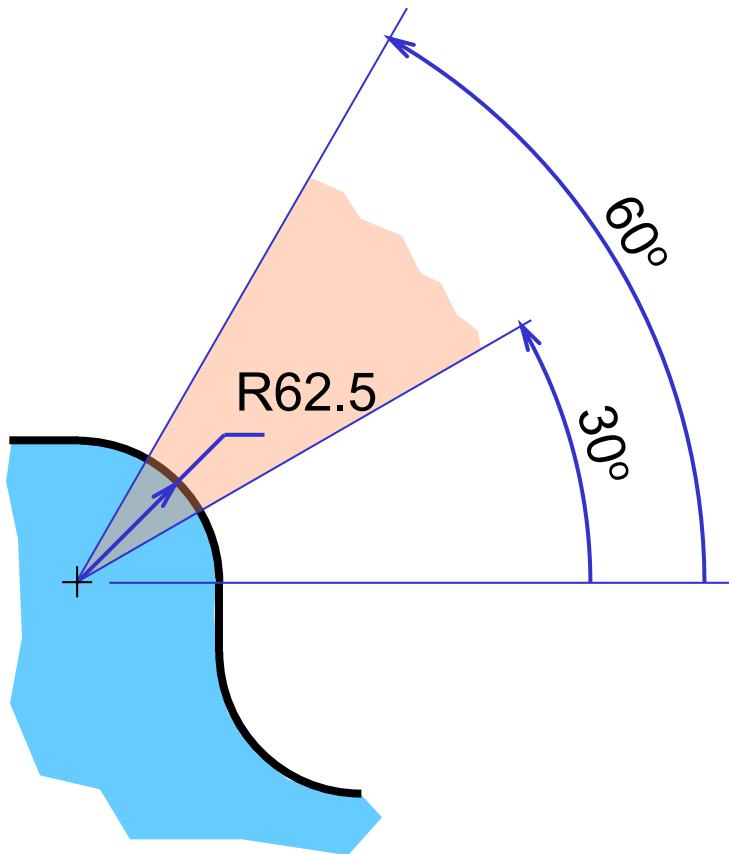

# ARC

- Use the **foreshortened radial dimension line**, when arc's center locates outside the sheet or interfere with other views.

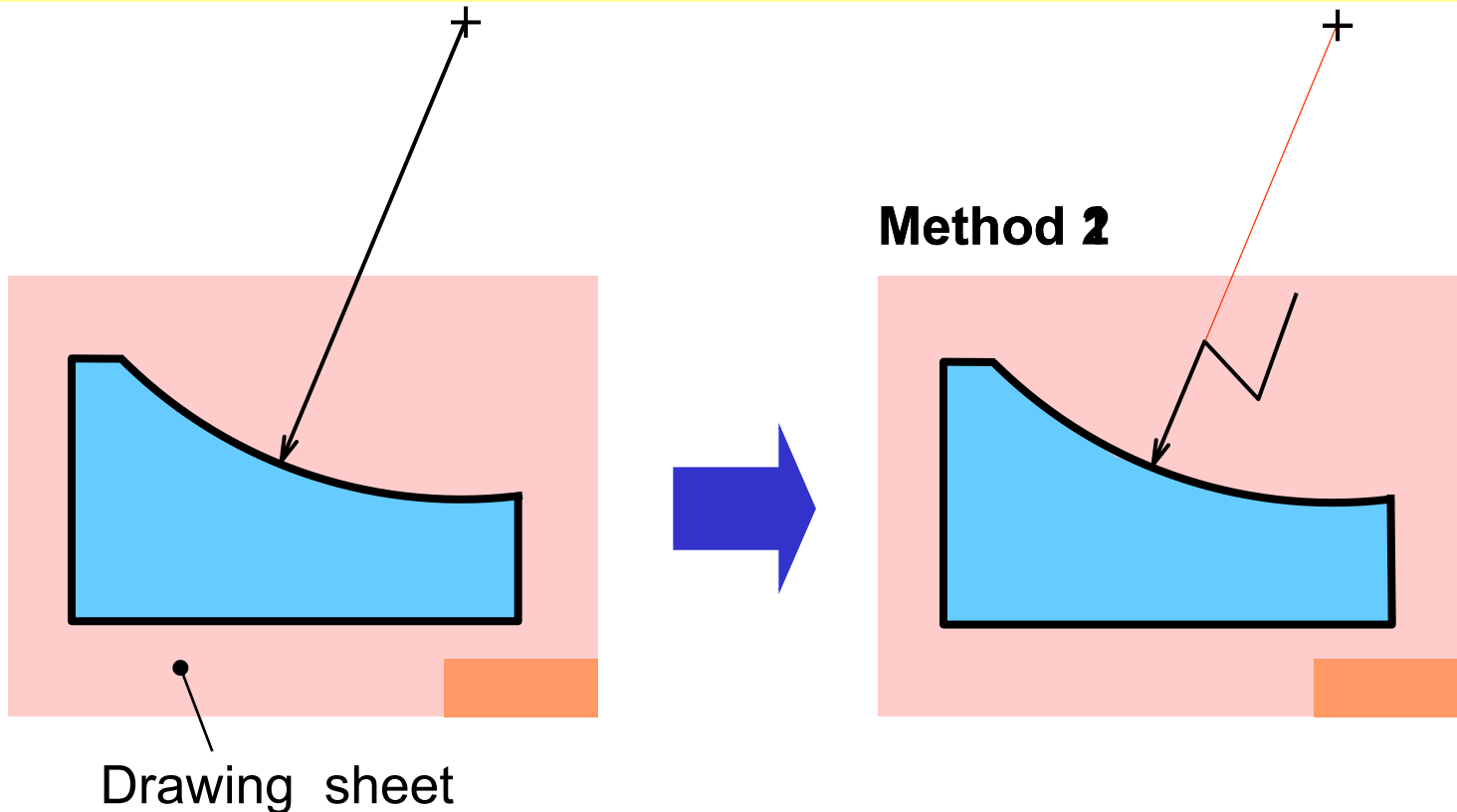

# FILLETS AND ROUNDS

- Give the radius of a typical fillet only by using a *local* note.
- If all fillets and rounds are uniform in size, dimension may be omitted, but it is necessary to add the note “ *All fillets and round are Rxx.* ”

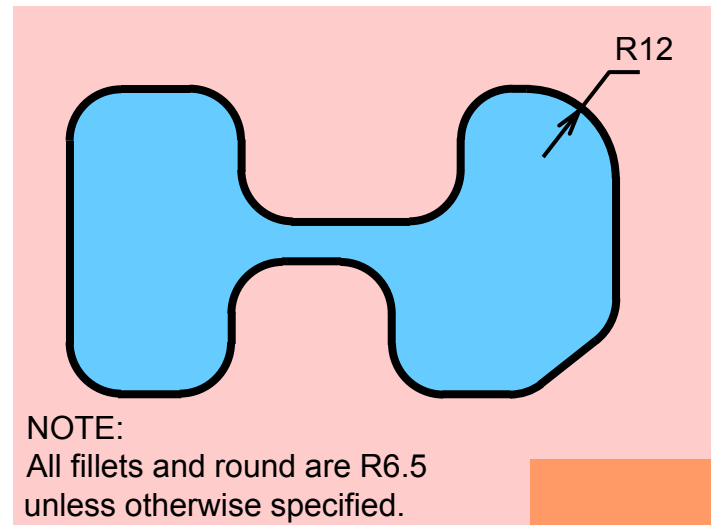
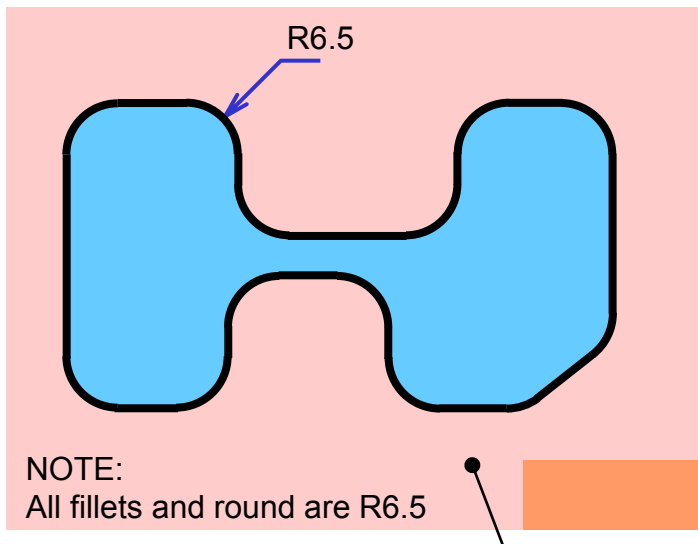

Drawing sheet

# CURVE

- The curve constructed from two or more arcs, requires the dimensions of **radii** and **center's location**.

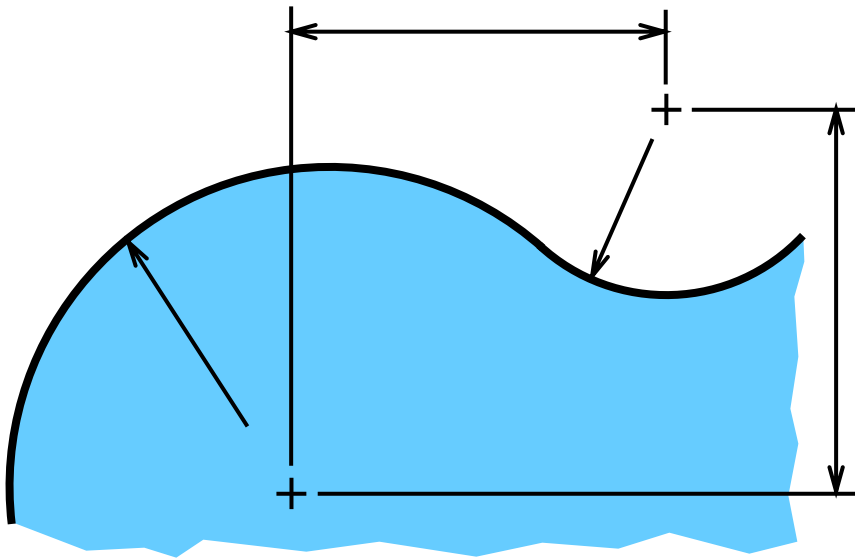

## COMMON MISTAKE

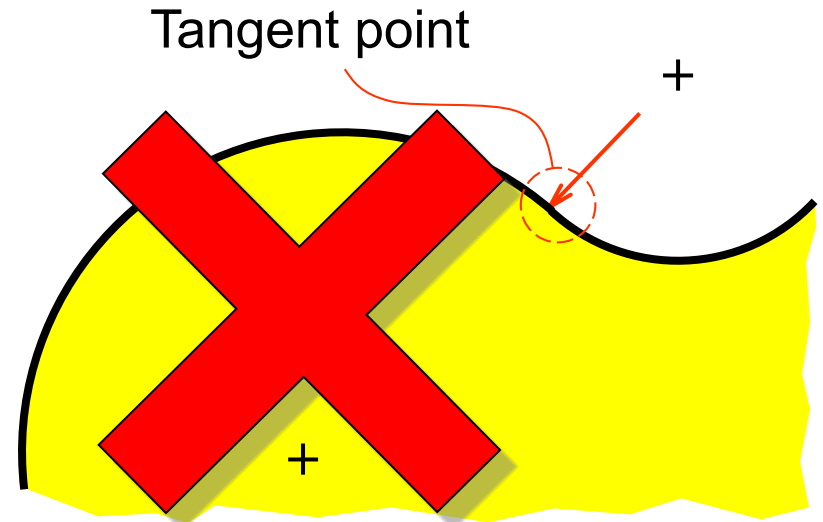

# CYLINDER

- Size dimensions are **diameter** and **length**.
- Location dimension **must** be located from its center lines and **should be** given in circular view.

## Measurement method

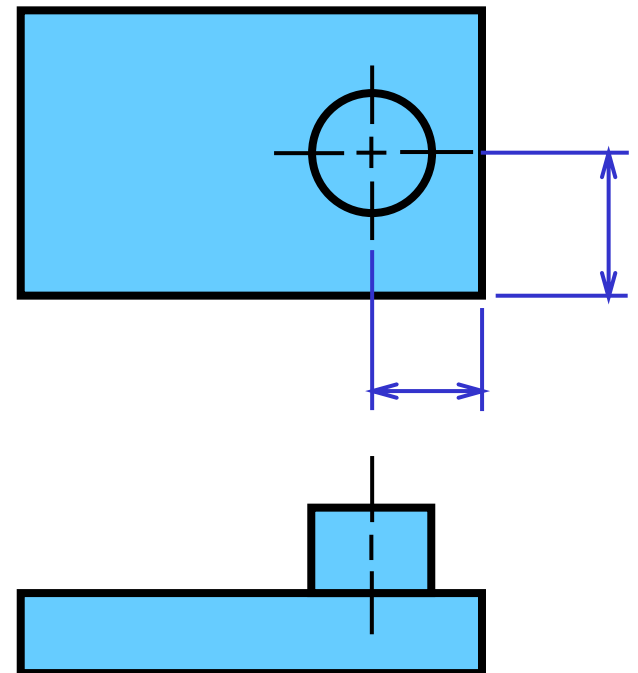
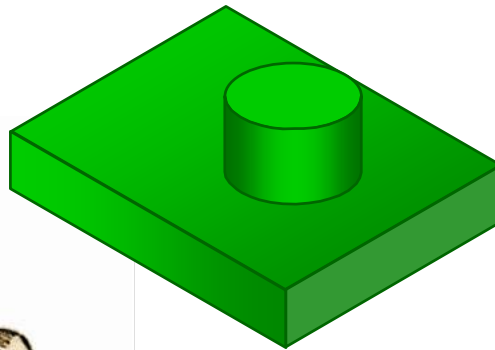
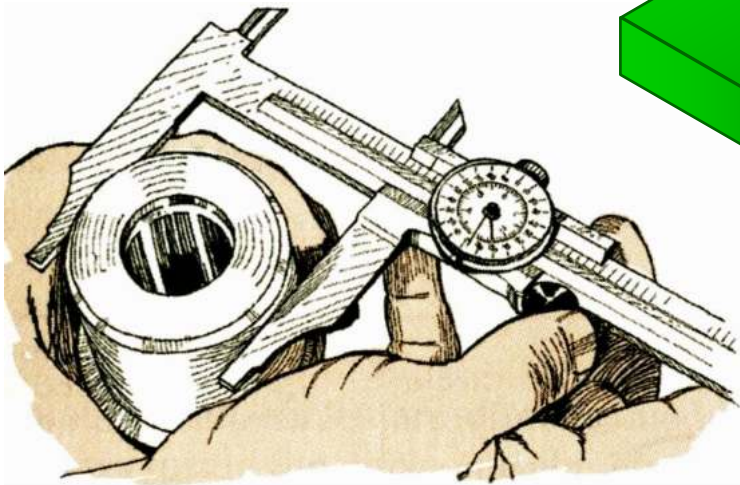

# CYLINDER

- Diameter **should be** given in a longitudinal view with the symbol “ $\phi$ ” placed before the figures.

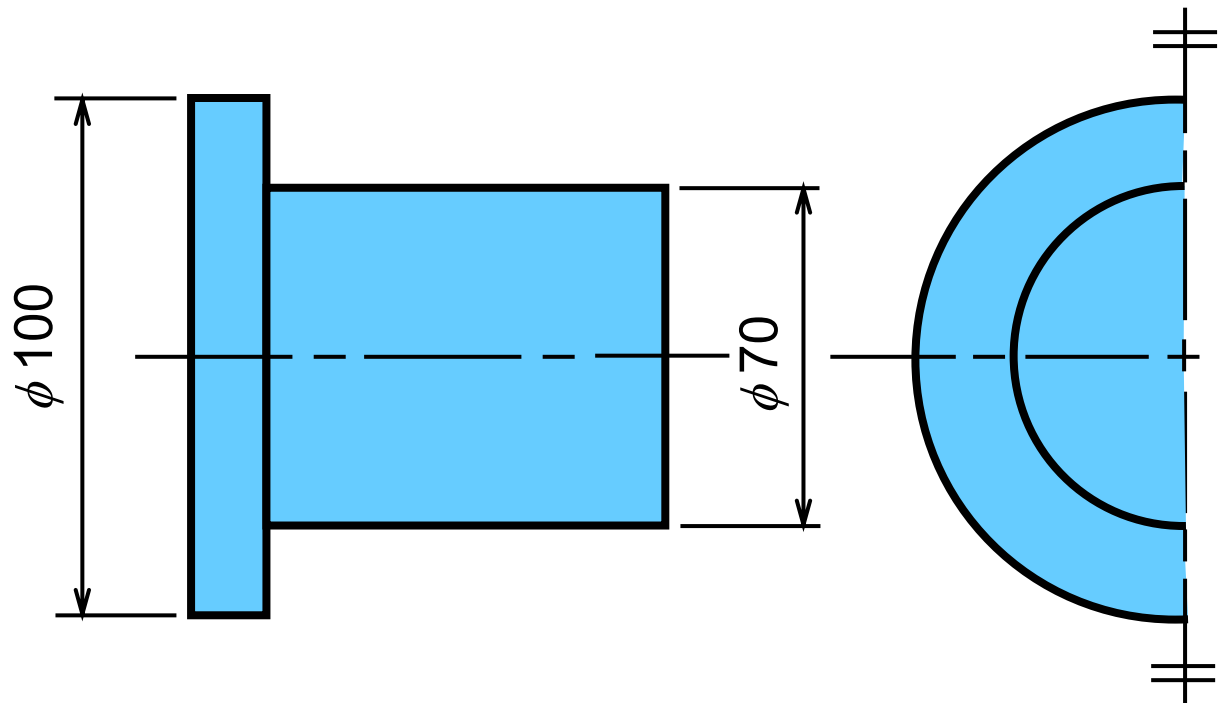
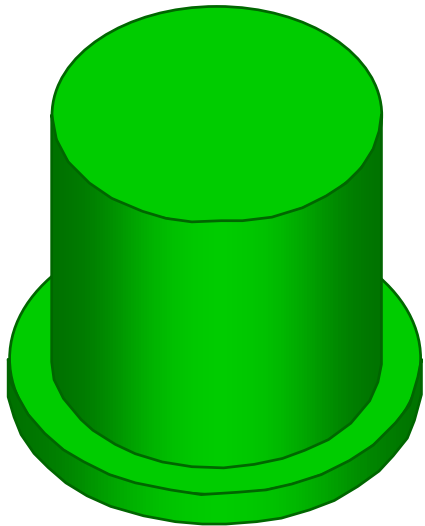

# HOLES

- Size dimensions are **diameter** and **depth**.
- Location dimension **must** be located from its center lines and should be given in circular view.

## Measurement method

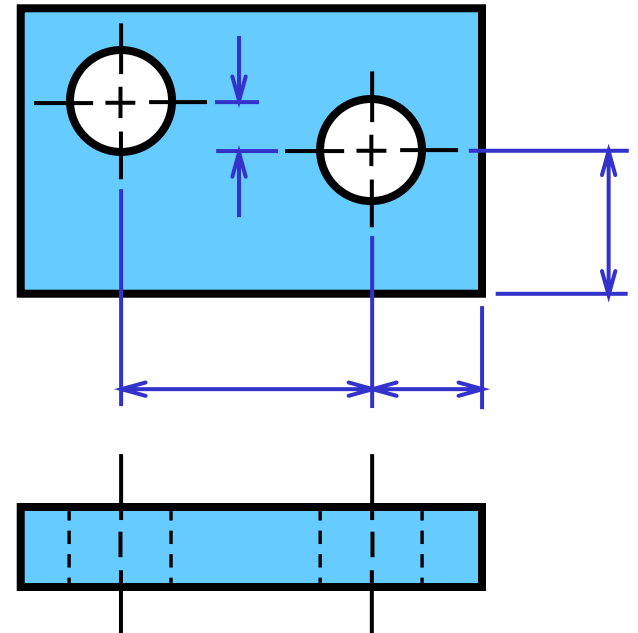
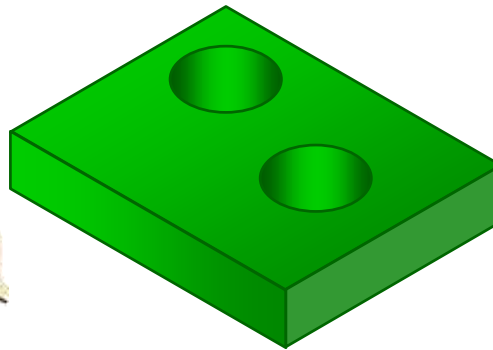
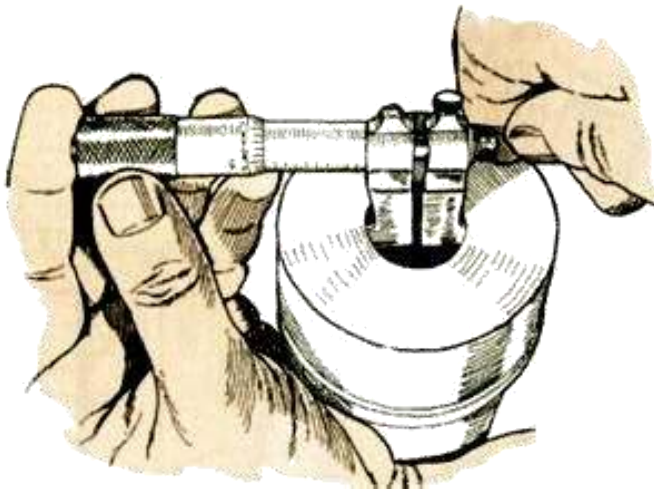

# HOLES : SMALL SIZE

- Use leader line and local note to specify **diameter** and **hole's depth** in the circular view.

## 1) Through thickness hole

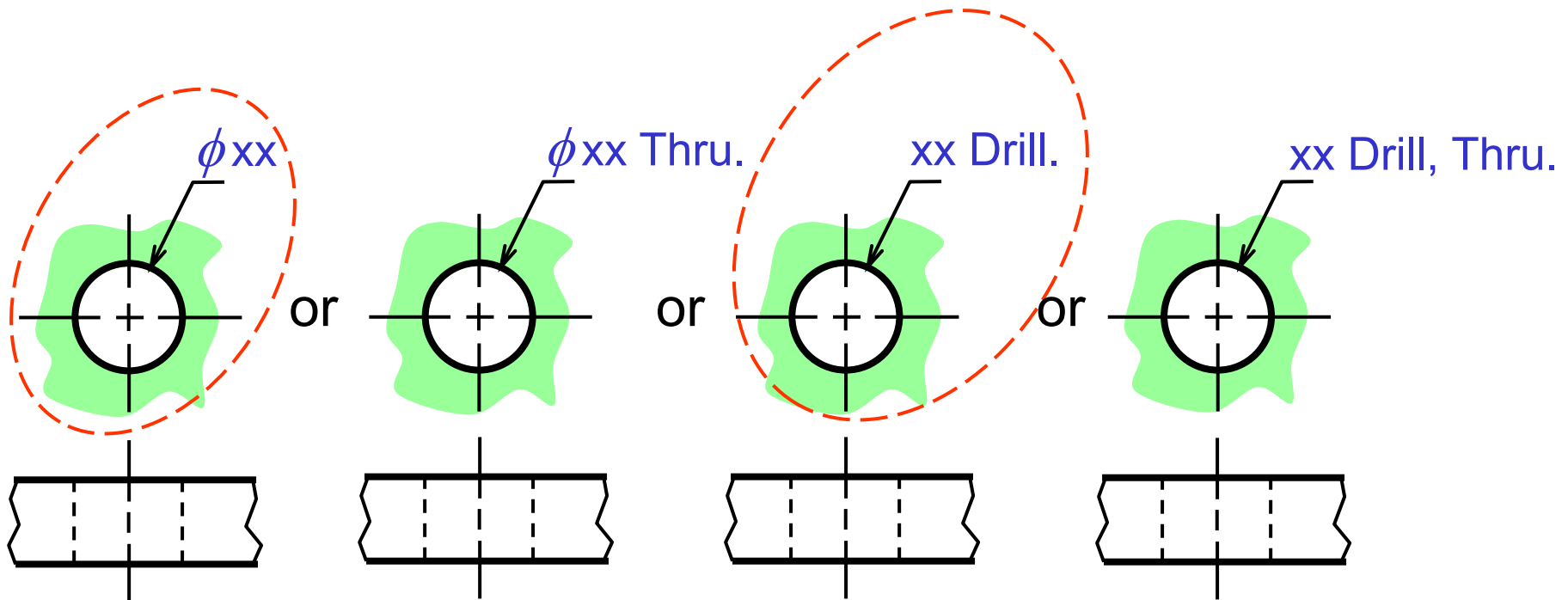

# HOLES : SMALL SIZE

- Use leader line and local note to specify **diameter** and **hole's depth** in the circular view.

## 2) Blind hole

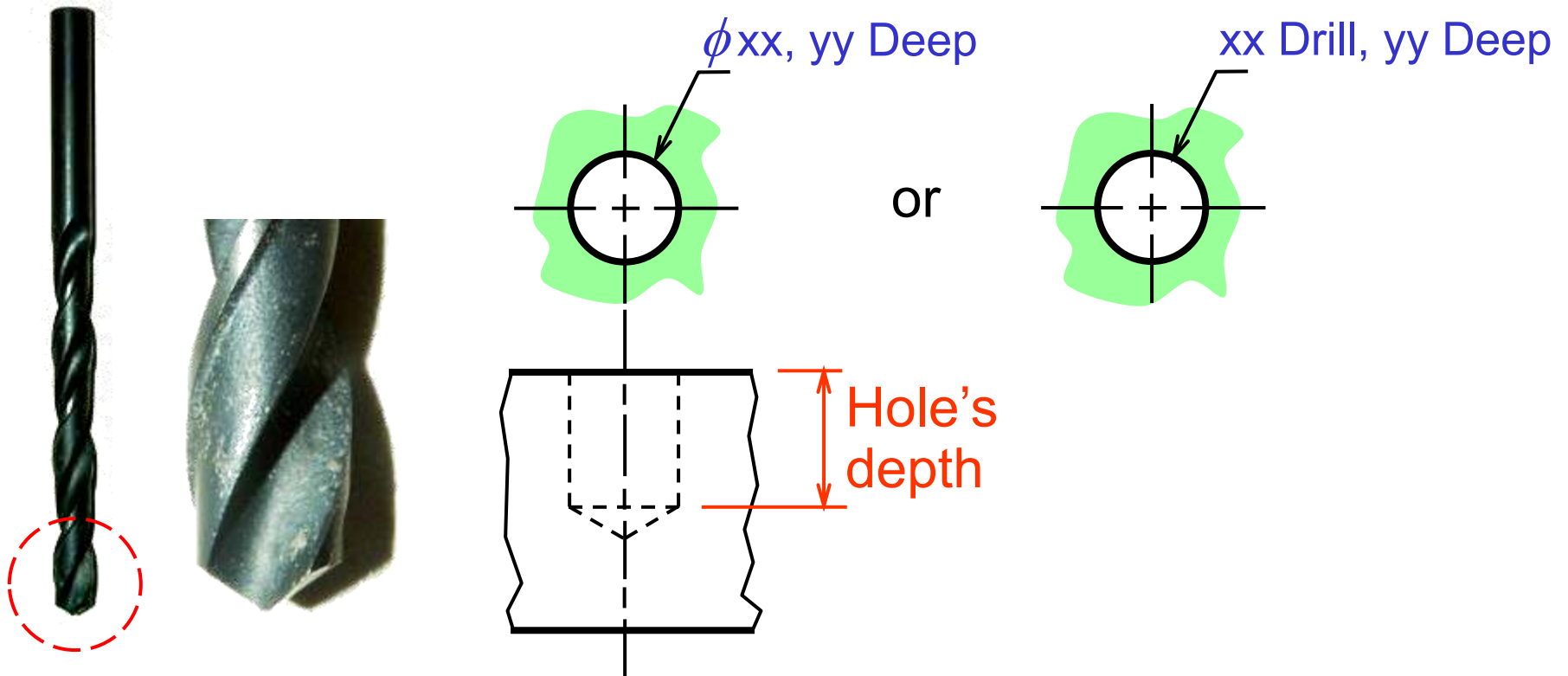

# HOLES : LARGE SIZE

Use extension and  
dimension lines

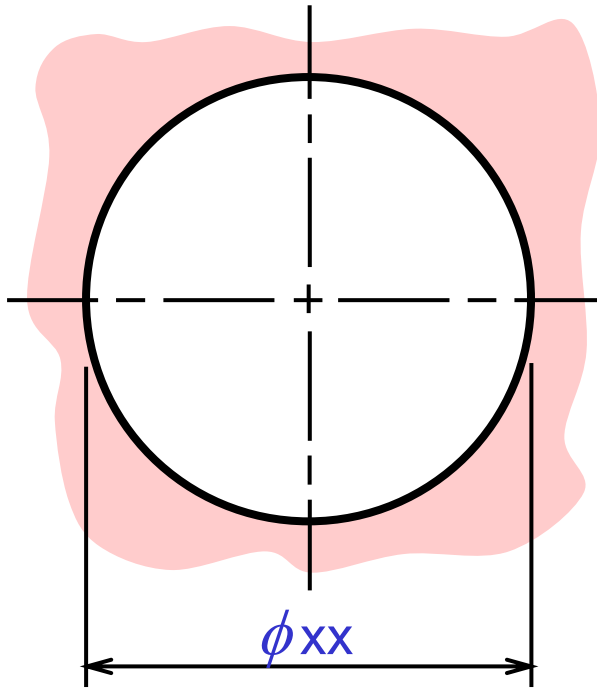

Use diametral  
dimension line

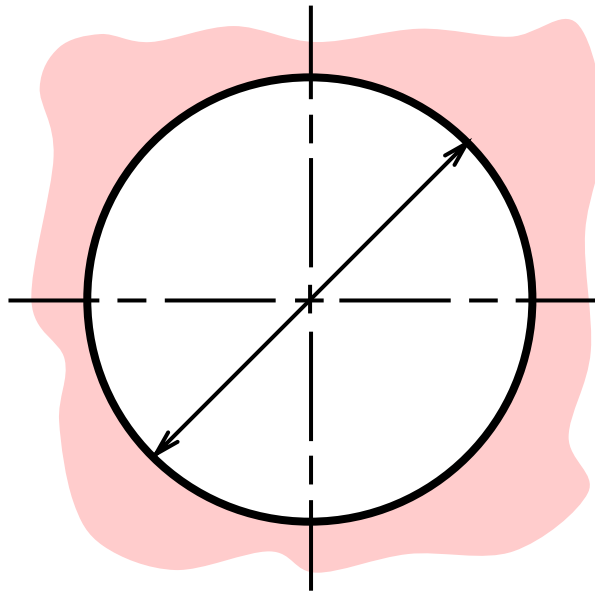

Use leader line  
and note

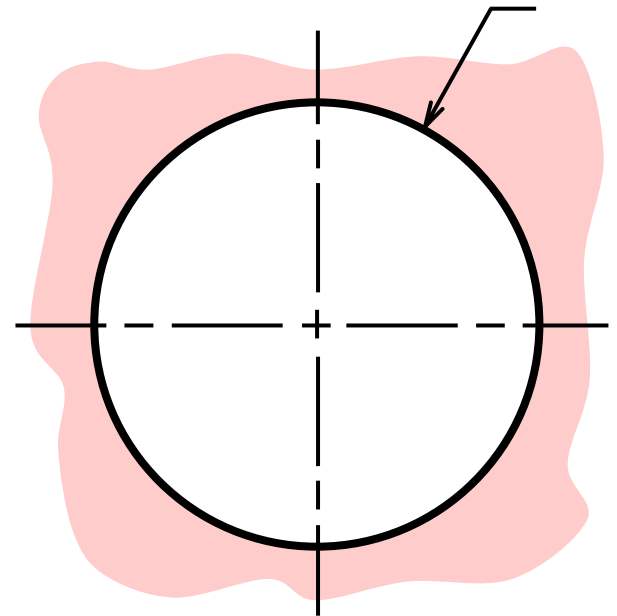

# HOLES

## COMMON MISTAKE

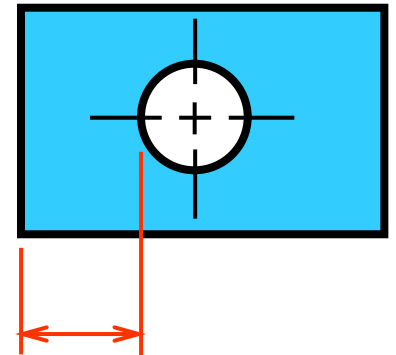
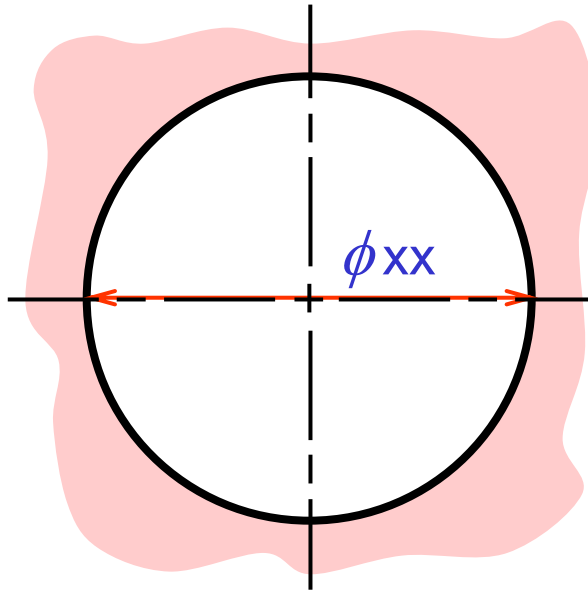
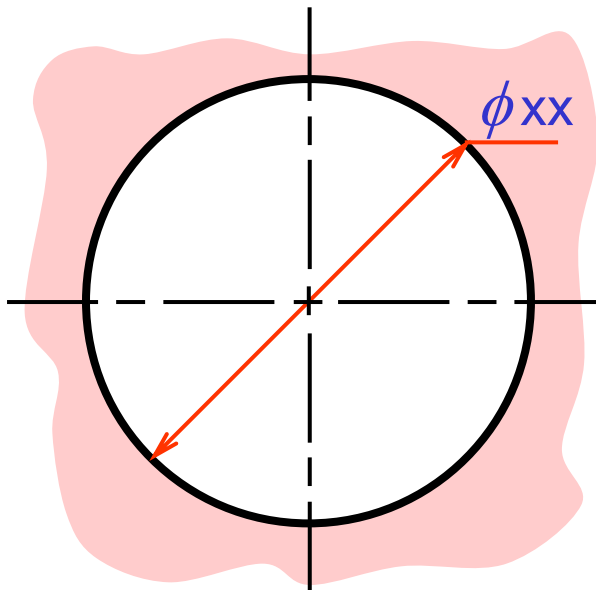
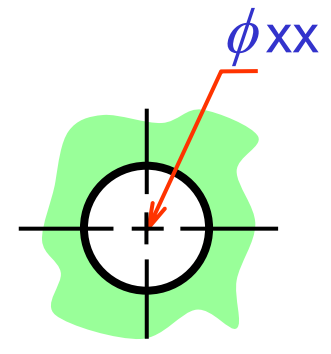
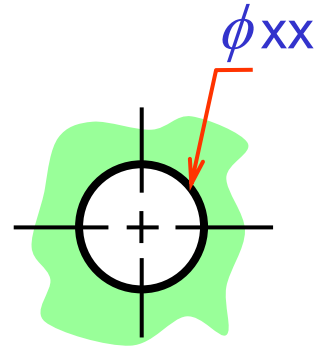
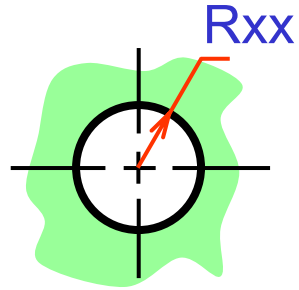
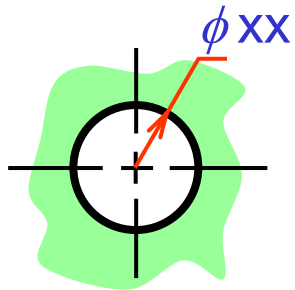

# CHAMFER

- Use leader line and note to indicate **linear distance** and **angle** of the chamfer.

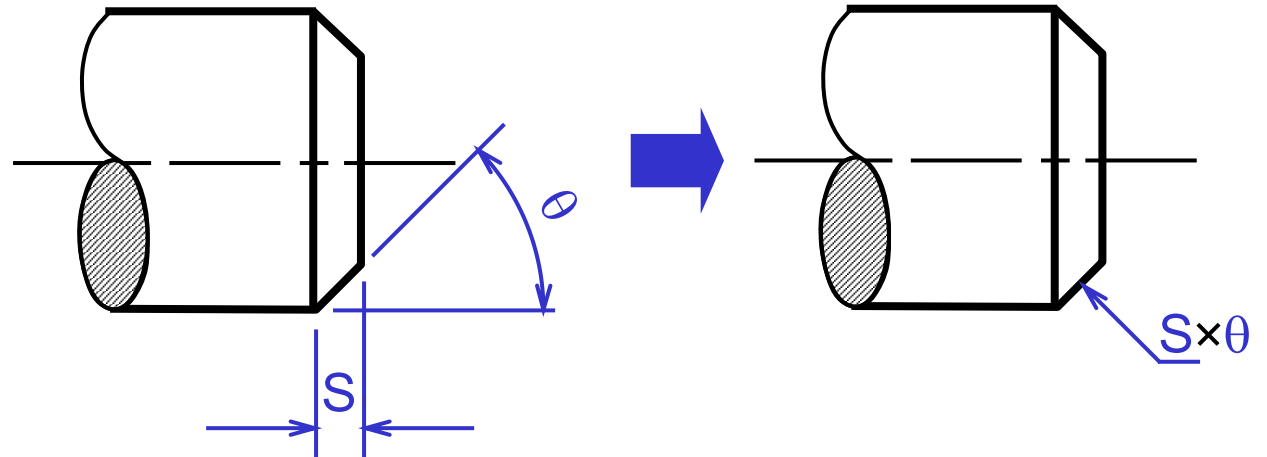
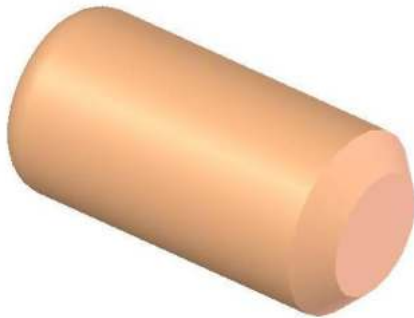

For a 45° chamfer

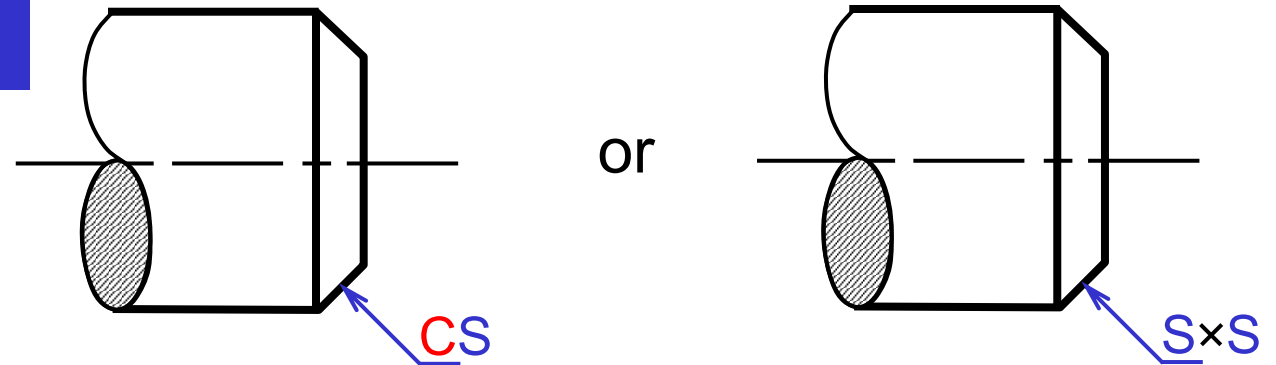

# ROUNDED-END SHAPES

- Dimensioned according to the manufacturing method used.

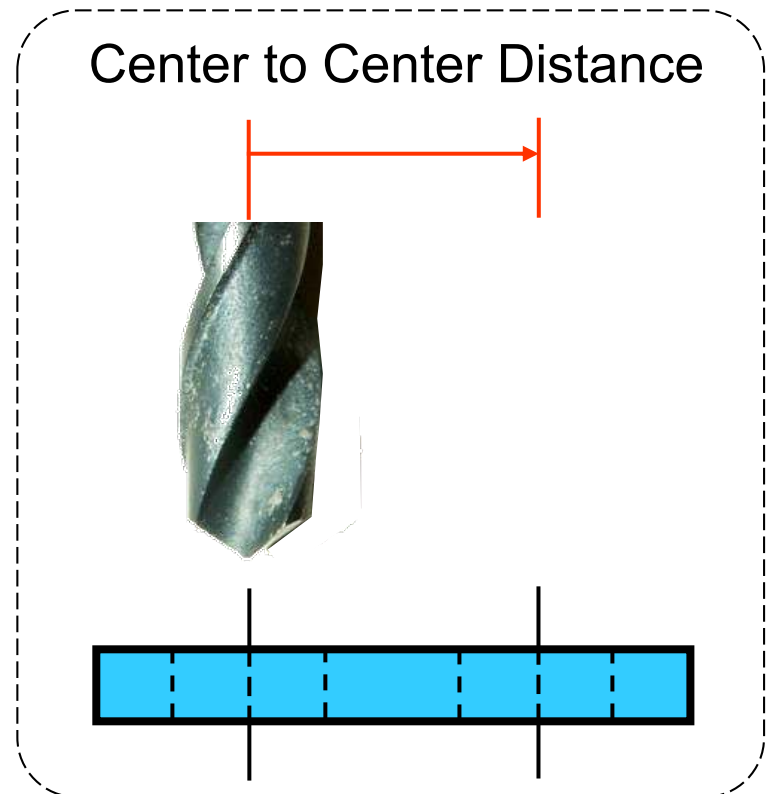
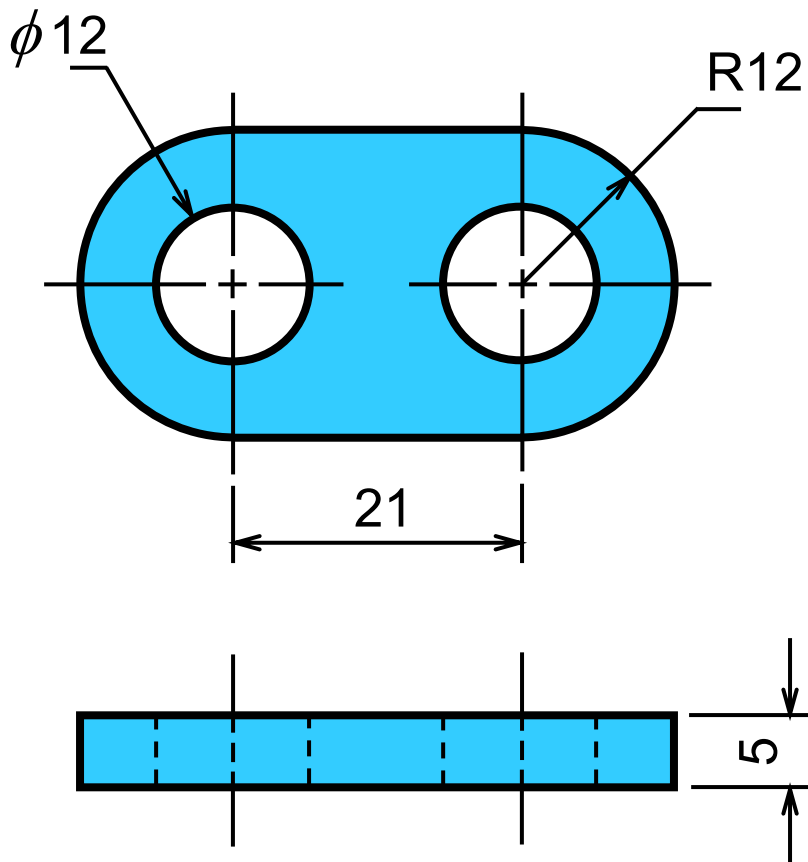

# ROUNDED-END SHAPES

- Dimensioned according to the manufacturing method used.

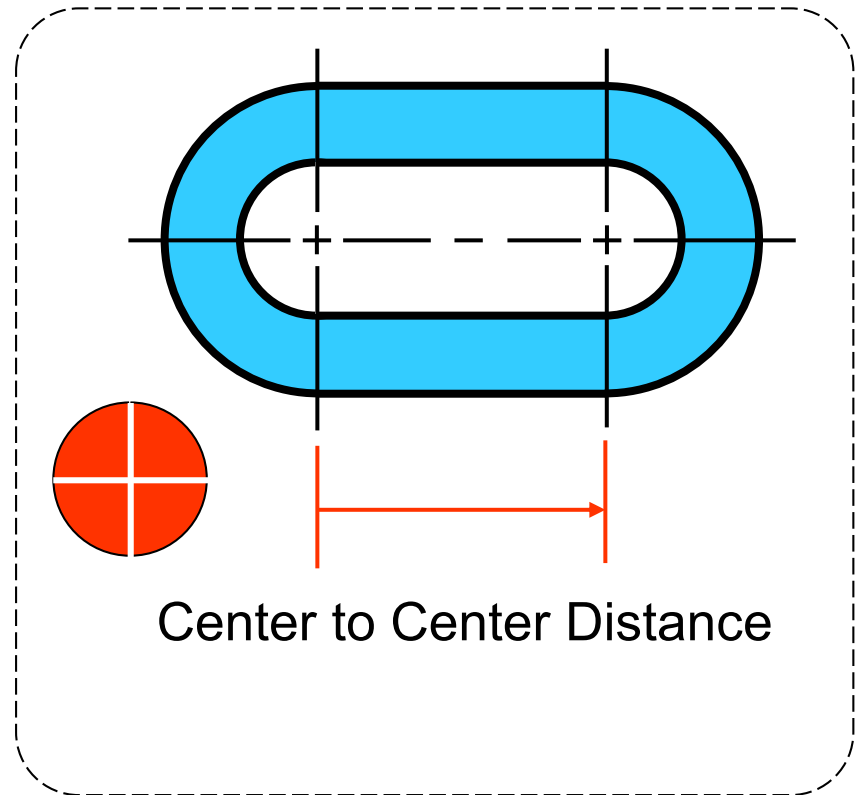
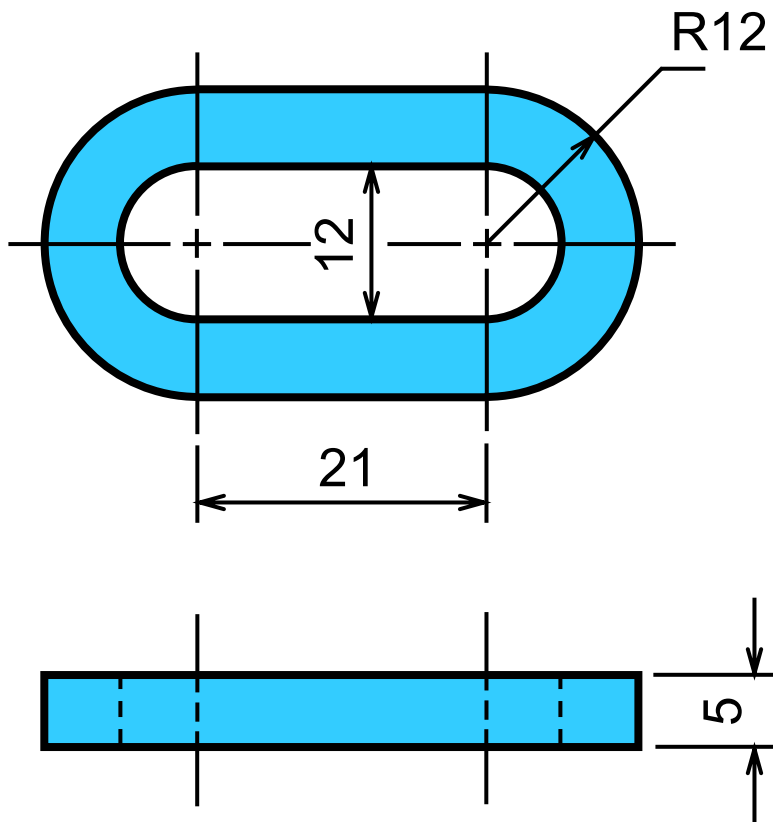

# ROUNDED-END SHAPES

- Dimensioned according to the manufacturing method used.

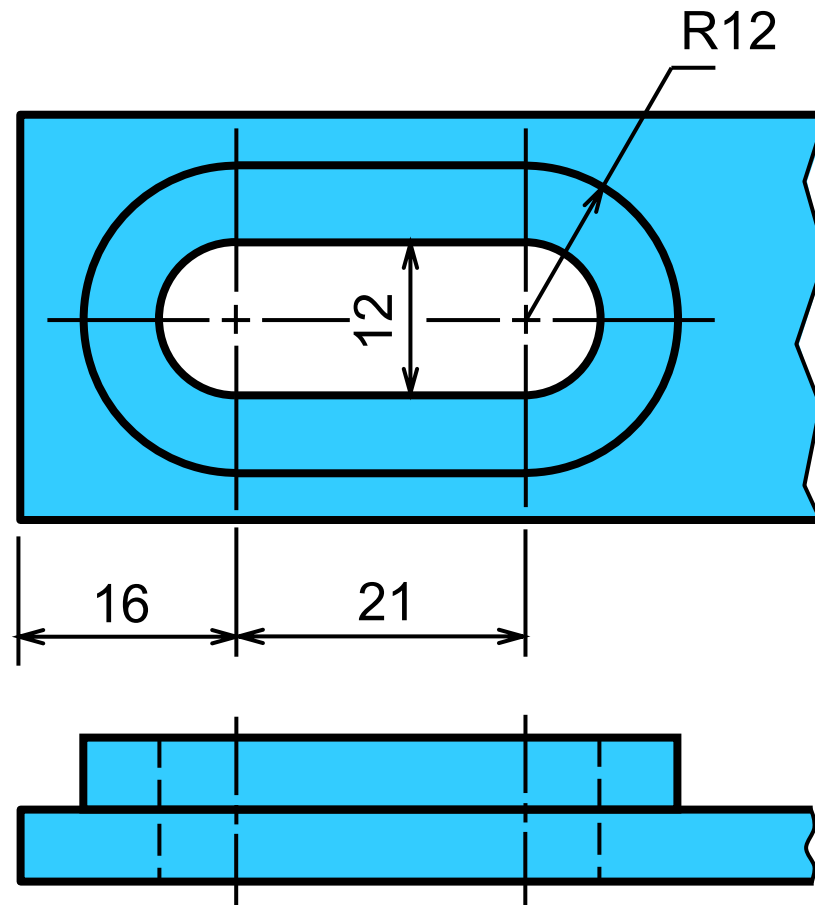

# ROUNDED-END SHAPES

- Dimensioned according to the manufacturing method used.

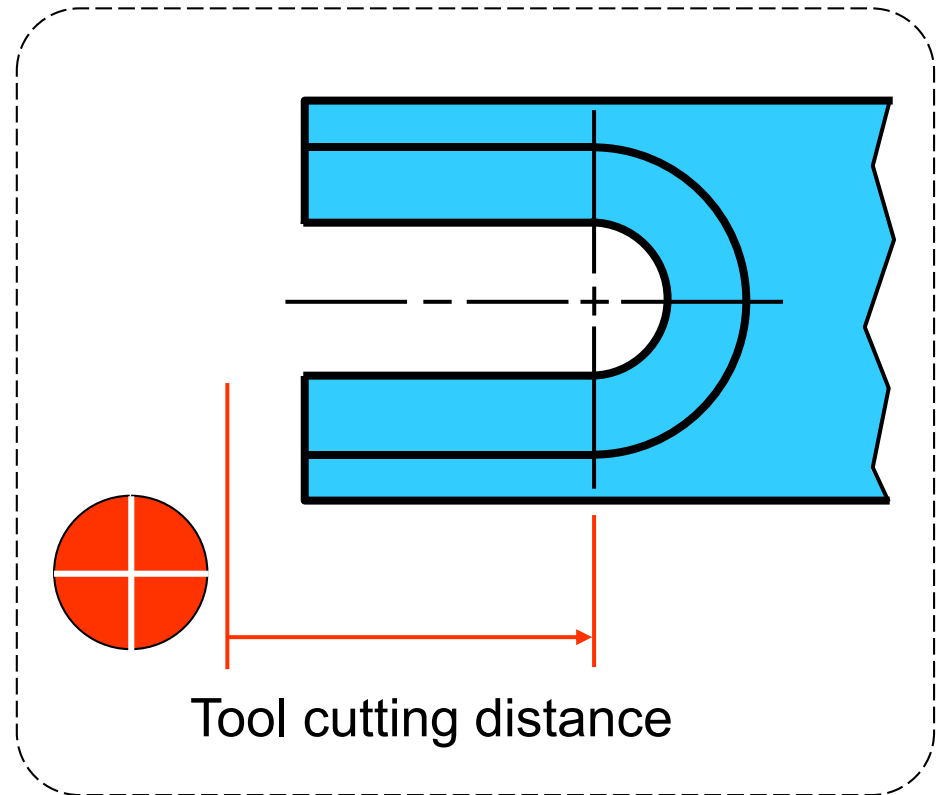
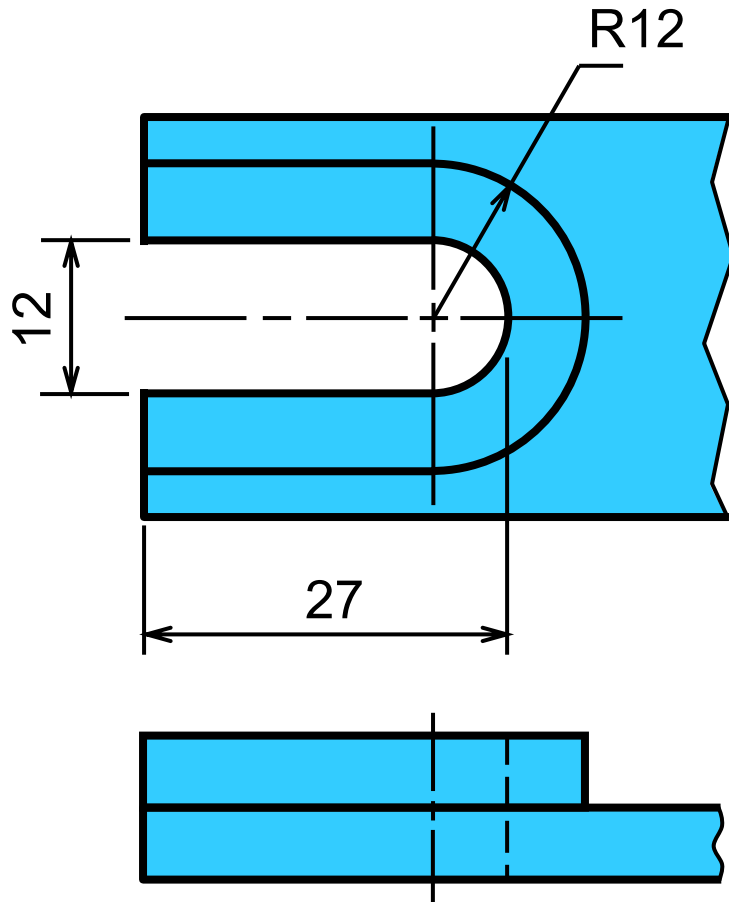

# ROUNDED-END SHAPES

- Dimensioned according to the **standard sizes** of another part to be assembled or manufacturing method used.

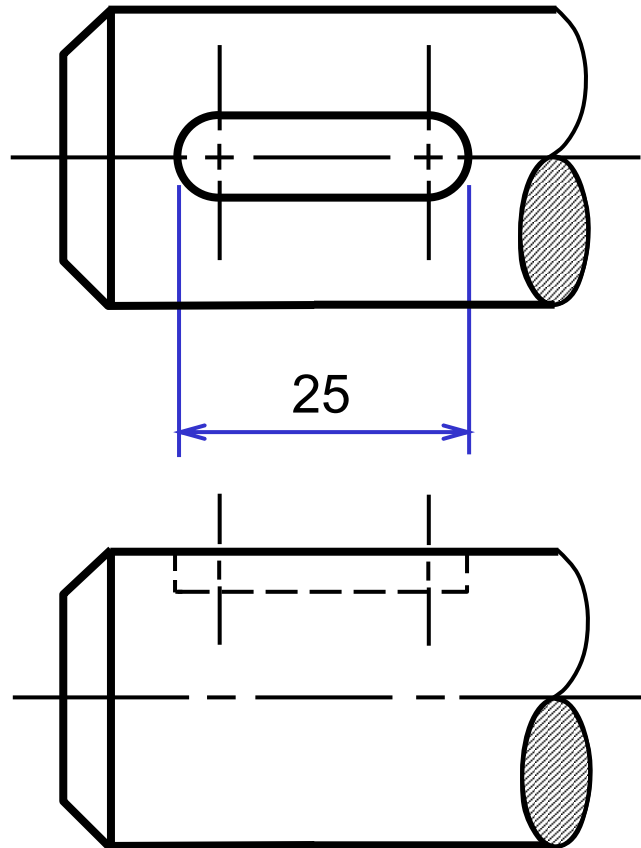

Key  
(standard part)

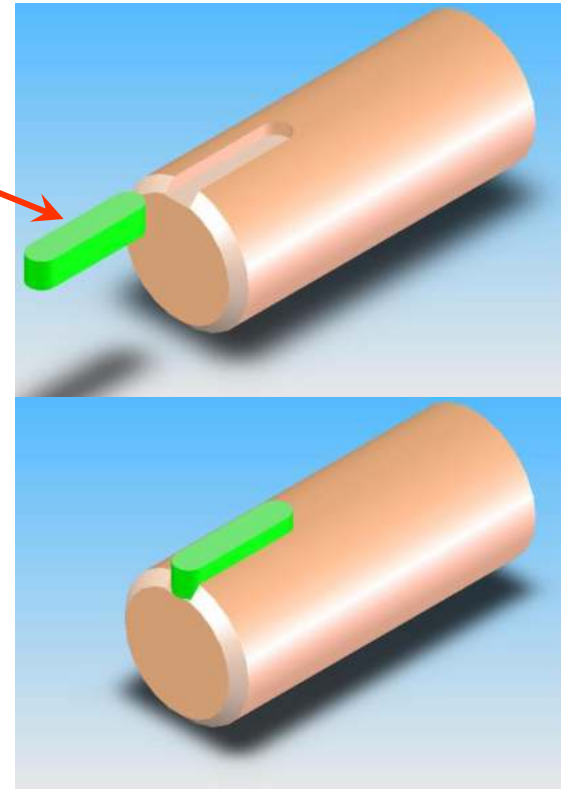

# ROUNDED-END SHAPES

- Dimensioned according to the **standard sizes** of another part to be assembled or manufacturing method used.

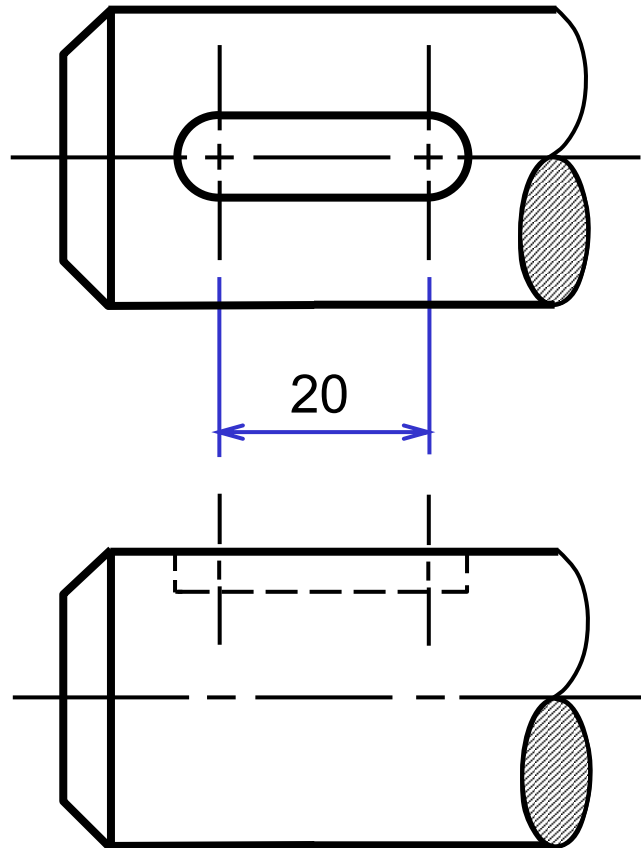

# ***Placement of Dimensions***



# RECOMMENDED PRACTICE

1. Extension lines, leader lines **should not** cross dimension lines.

**POOR**

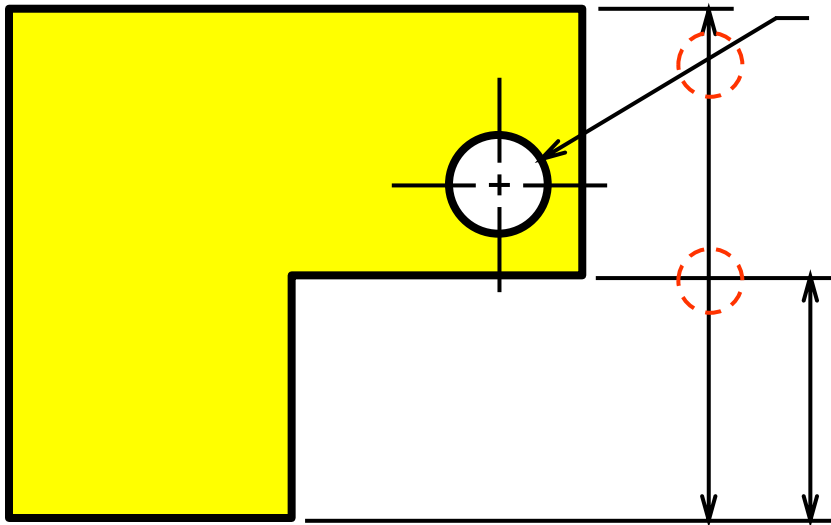

**GOOD**

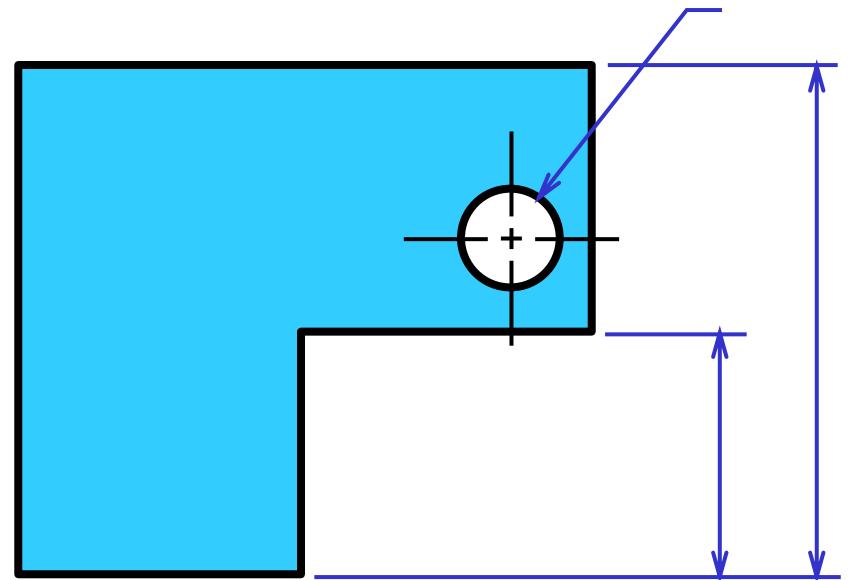

# RECOMMENDED PRACTICE

2. Extension lines **should be** drawn from the nearest points to be dimensioned.

**POOR**

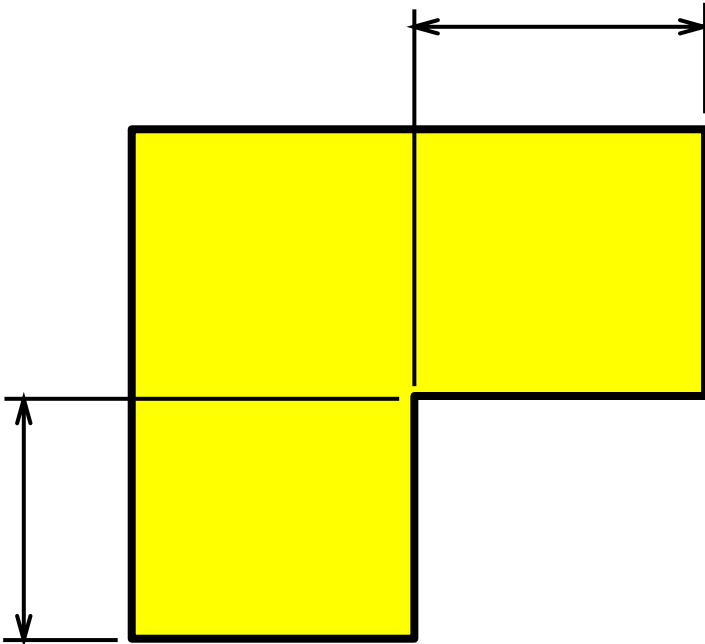

**GOOD**

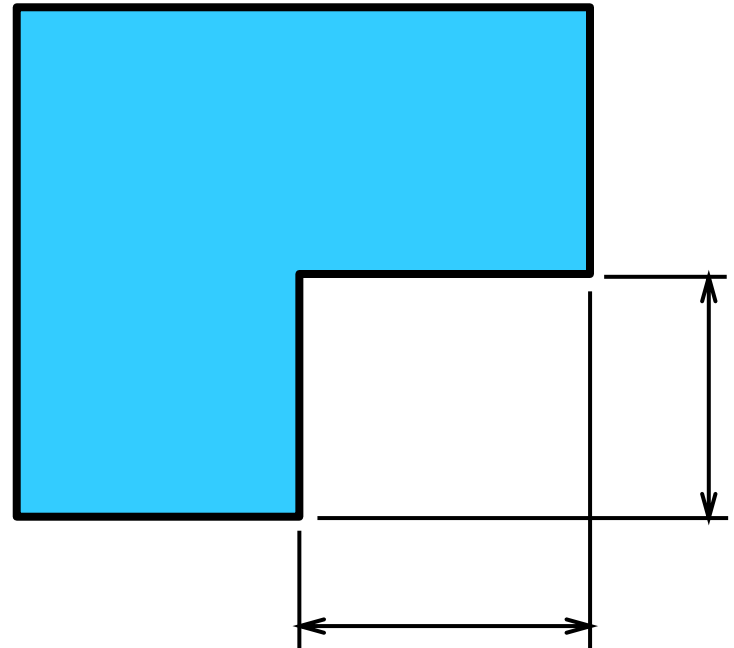

# RECOMMENDED PRACTICE

3. Extension lines of internal feature **can** cross visible lines **without** leaving a gap at the intersection point.

**WRONG**

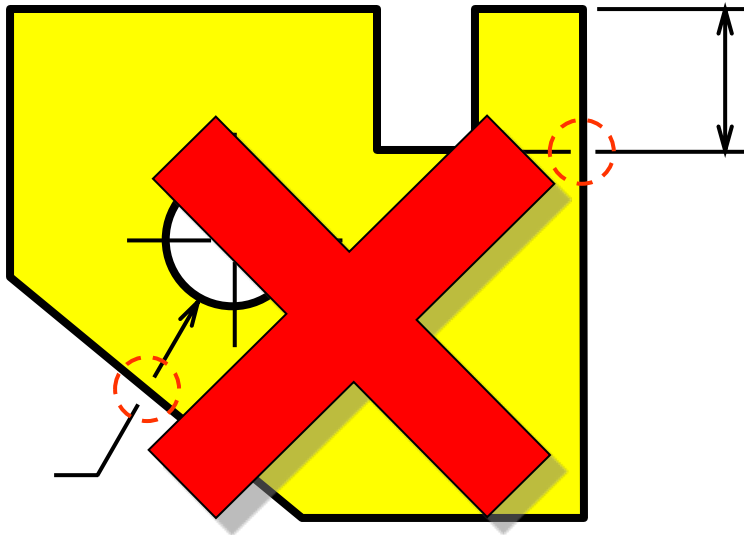

**CORRECT**

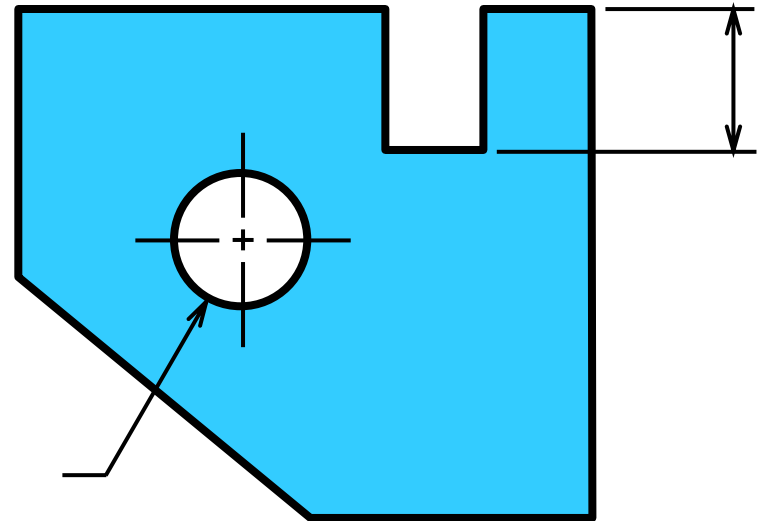

# RECOMMENDED PRACTICE

4. *Do not use object line, center line, and dimension line as an extension lines.*

**POOR**

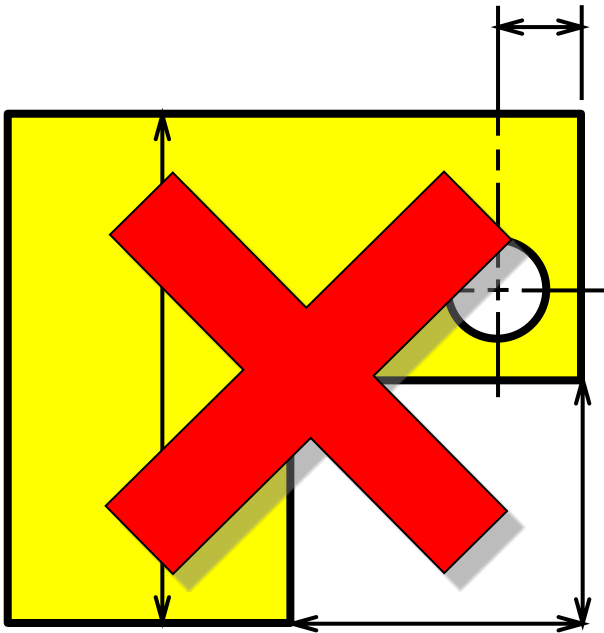

**GOOD**

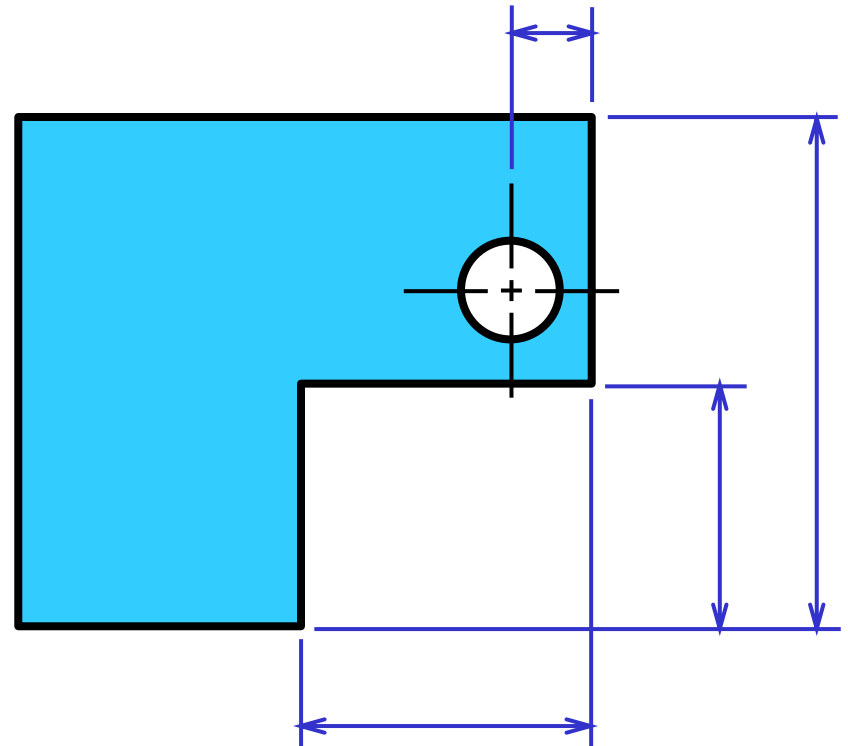

# RECOMMENDED PRACTICE

5. *Avoid dimensioning hidden lines.*

POOR

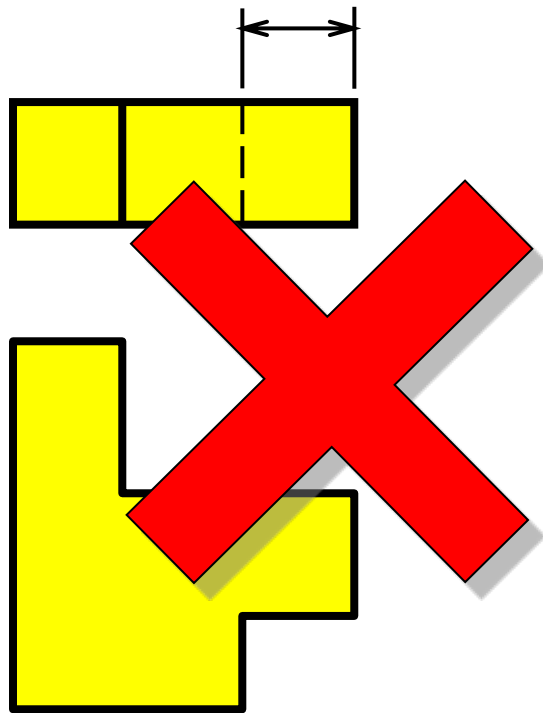

GOOD

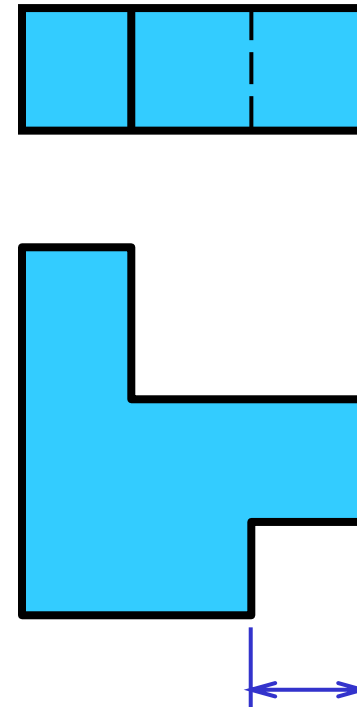

# RECOMMENDED PRACTICE

6. Place dimensions **outside** the view, unless placing them inside improve the clarity.

**POOR**

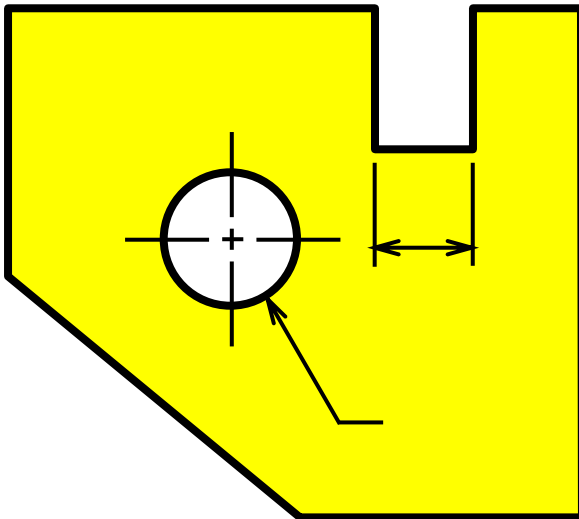

**GOOD**

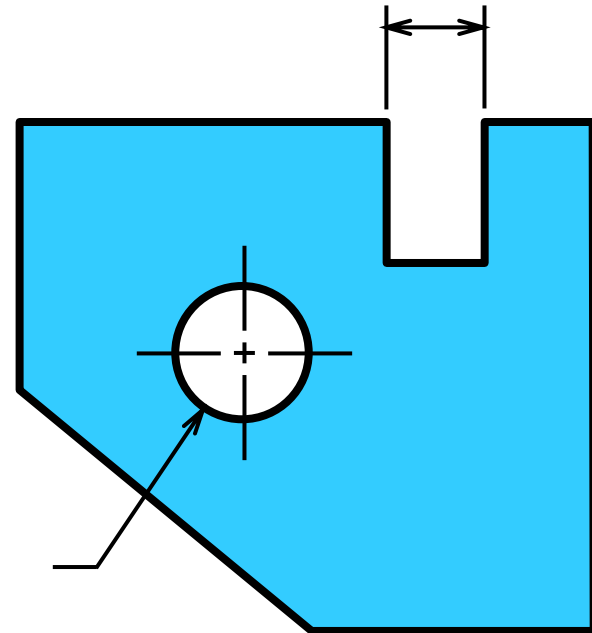

# RECOMMENDED PRACTICE

6. Place dimensions **outside** the view, unless placing them inside improve the clarity.

**JUST OK !!!**

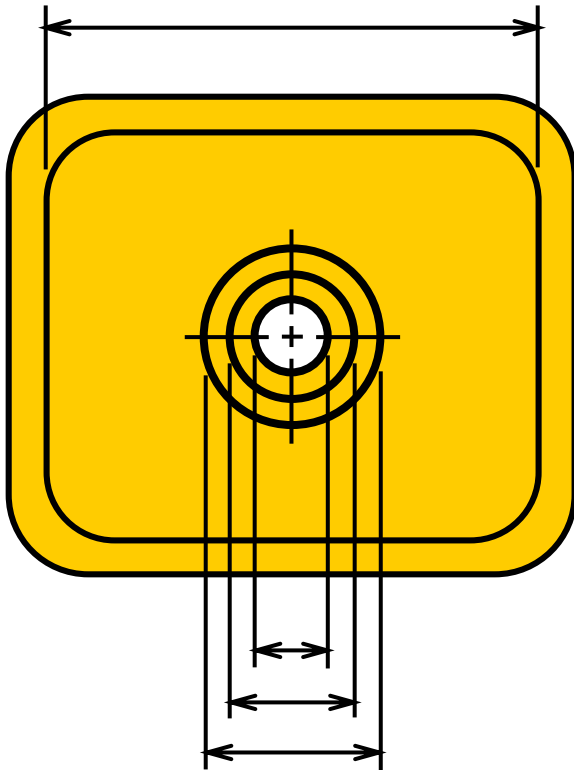

**BETTER**

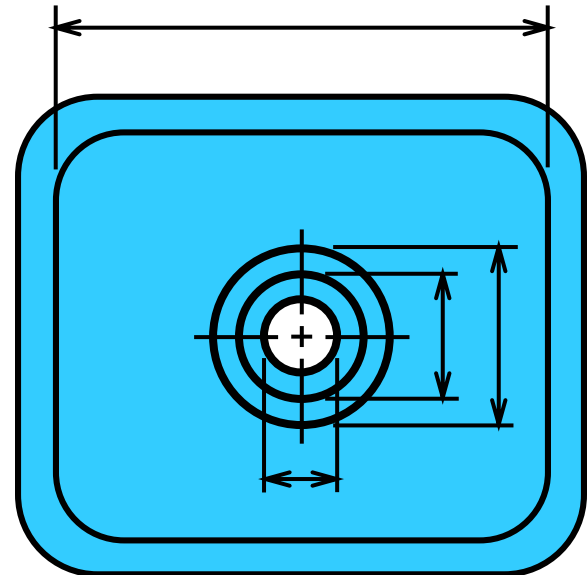

# RECOMMENDED PRACTICE

*7. Apply the dimension to the view that clearly show the shape or features of an object.*

**POOR**

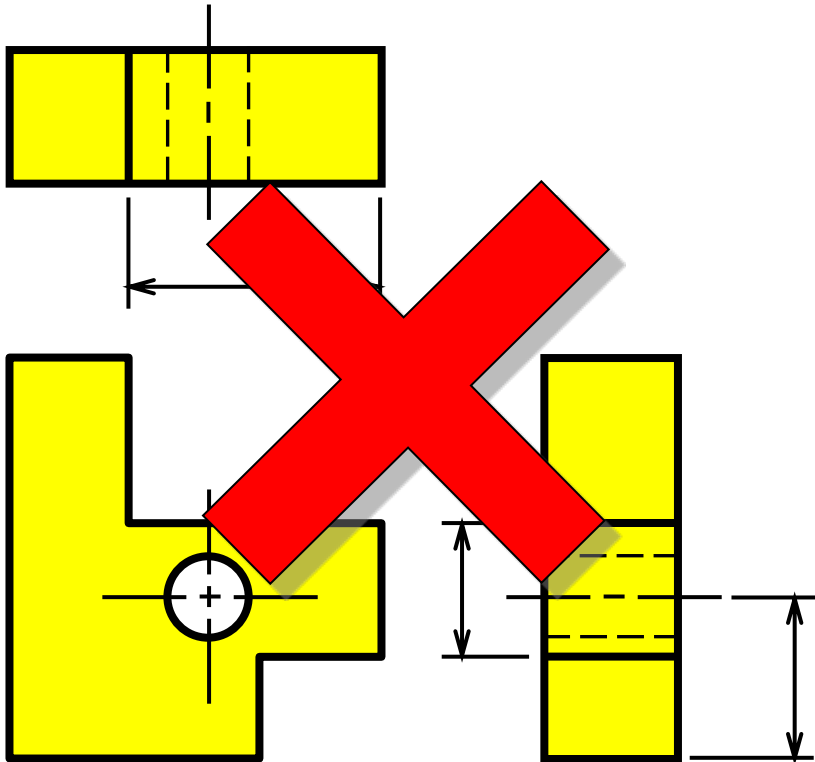

**GOOD**

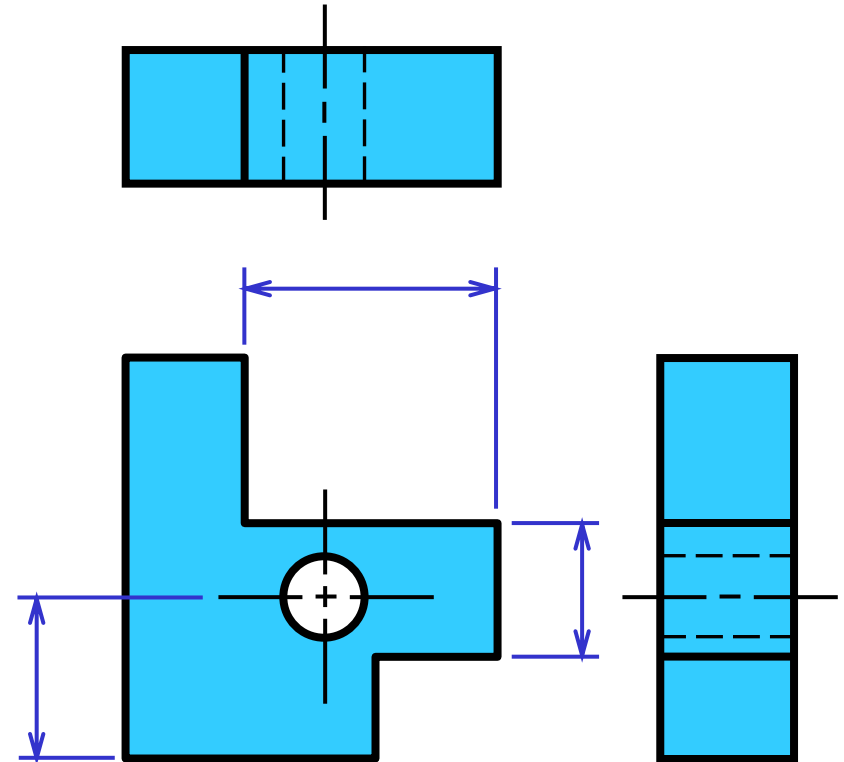

# RECOMMENDED PRACTICE

8. Dimension lines should be lined up and grouped together as much as possible.

**POOR**

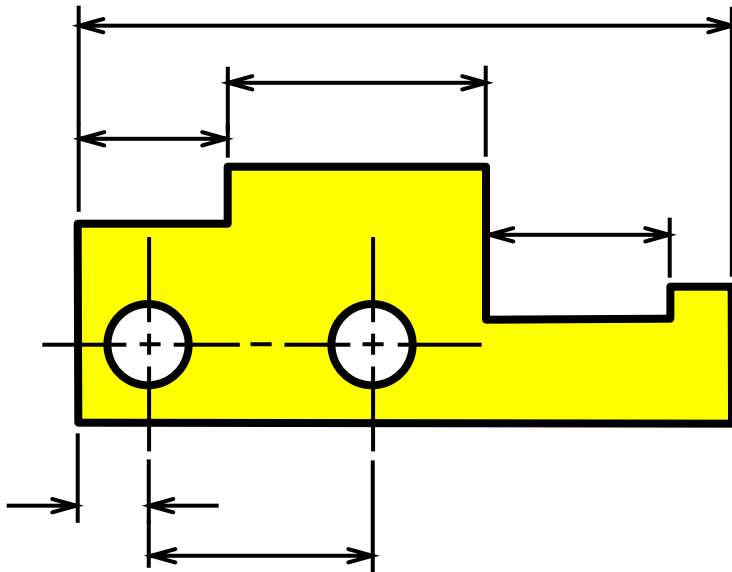

**GOOD**

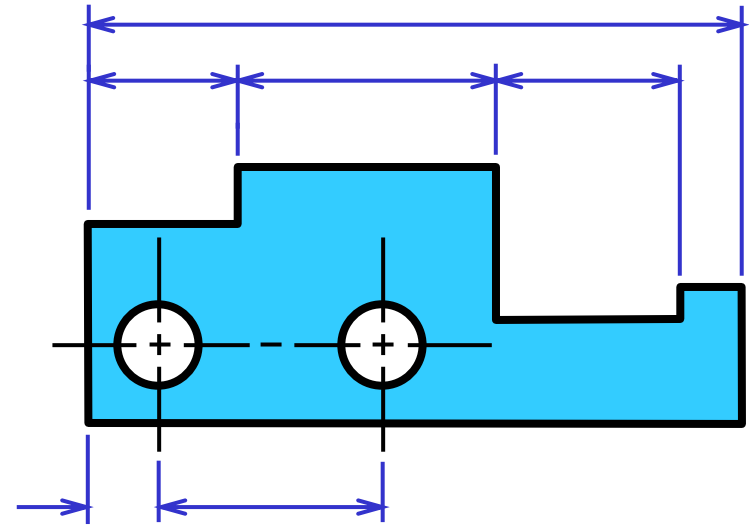

# RECOMMENDED PRACTICE

9. *Do not repeat a dimension.*

**POOR**

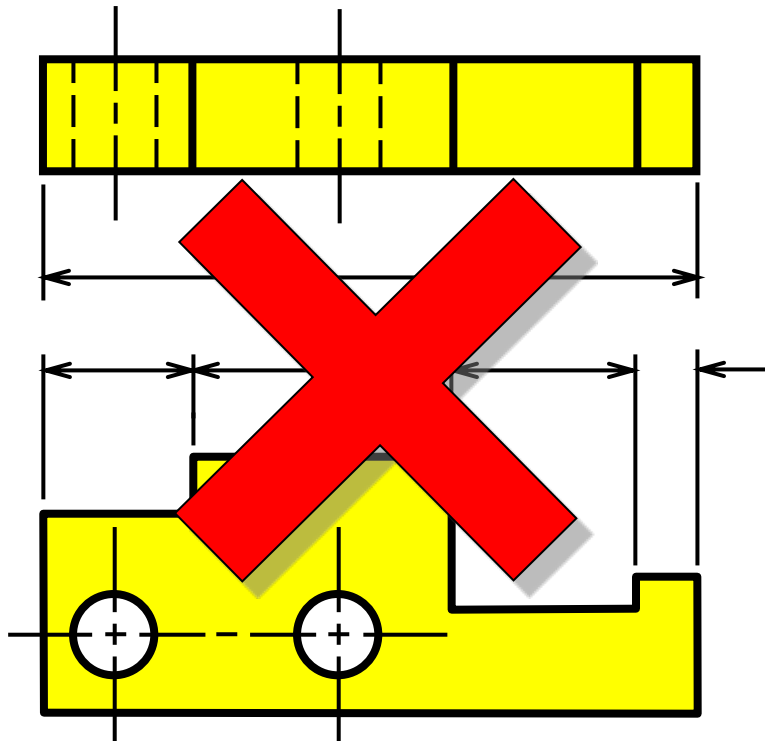

**GOOD**

