



MECH-320 Kinematics of Mechanical Systems

2

Course lectures Slides prepared by

Professor JAMAL M. NAZZAL

Chairman of Mechanical Engineering Department

2020 - 2021

2. Mechanisms and Simple Machines

MECHANISM: THE FUNDAMENTAL PHYSICAL OR CHEMICAL PROCESSES INVOLVED IN OR RESPONSIBLE FOR AN ACTION, REACTION OR OTHER NATURAL PHENOMENON

Machine: an assemblage of parts that transmit forces, motion and energy in a predetermined manner.

Simple Machine: any of various elementary mechanisms having the elements of which all machines are composed. Included in this category are the lever, wheel and axle, pulley, inclined plane, wedge and the screw.

The word mechanism has many meanings. In [kinematics](#), a mechanism is a means of transmitting, controlling, or constraining relative movement ([Hunt78](#)).

Movements which are electrically, magnetically, pneumatically operated are excluded from the concept of **mechanism**.

The central theme for mechanisms is rigid bodies connected together by joints.

A **machine** is a combination of rigid or resistant bodies, formed and connected so that they move with definite relative motions and transmit force from the source of power to the resistance to be overcome. **A machine has two functions:** transmitting definite relative motion and transmitting force. These functions require strength and rigidity to transmit the forces.

The term **mechanism is applied to** the combination of geometrical bodies which constitute a machine or part of a machine. **A mechanism may therefore be defined as a combination of rigid or resistant bodies,** formed and connected so that they move with definite relative motions with respect to one another ([Ham et al. 58](#)).

Although a truly rigid body does not exist, many engineering components are rigid because their deformations and distortions are negligible in comparison with their relative movements.

The similarity between machines and mechanisms is that

- they are both combinations of rigid bodies
- the relative motion among the rigid bodies are definite.

The difference between machine and mechanism is that **machines transform energy to do work**, while mechanisms so not necessarily perform this function. The term machinery generally means machines and mechanisms. Figure 2-1 shows a picture of the main part of a diesel engine. The mechanism of its cylinder-link-crank parts is a slider-crank mechanism, as shown in Figure 2-2.

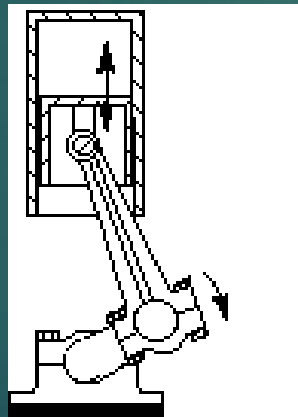

Figure 2-1 Cross section of a power cylinder in a diesel engine

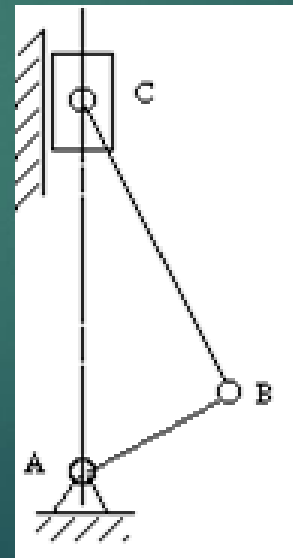
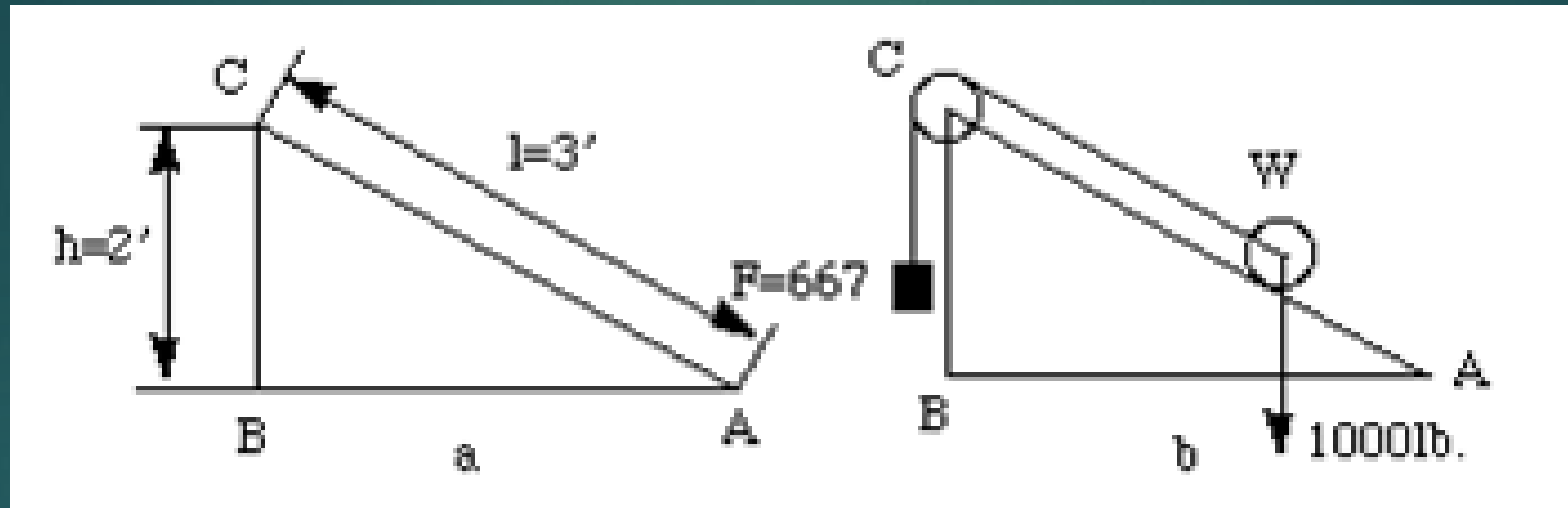

Figure 2-2 Skeleton outline

2.1 The Inclined Plane



2.1.1 Screw Jack

One of the most common application of the principle of the inclined plane is in the screw jack which is used to overcome a heavy pressure or raise a heavy weight of W by a much smaller force F applied at the handle. R represents the length of the handle and P the pitch of the screw, or the distance advances in one complete turn.

$$F \times 2\pi R = W \times P$$

$$F = \frac{W \times P}{2\pi R}$$

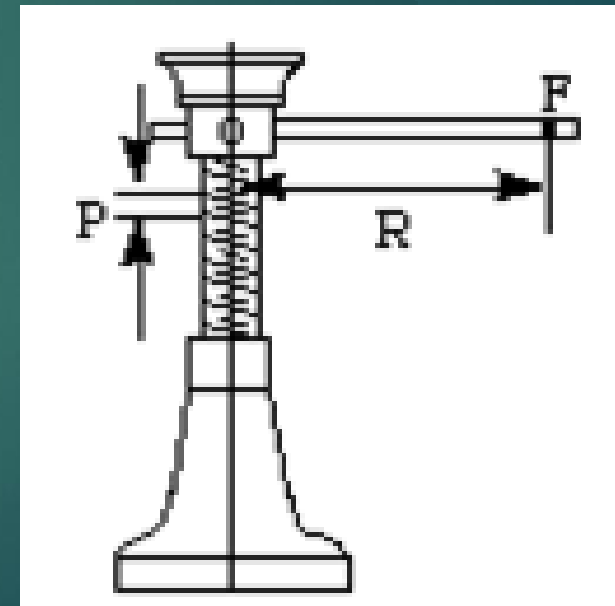

Figure 2-4 The screw jack

2.2 Gears

A gear, or toothed wheel, when in operation, may actually be considered as a lever with the additional feature that it can be rotated continuously, instead of rocking back and forth through a short distance.

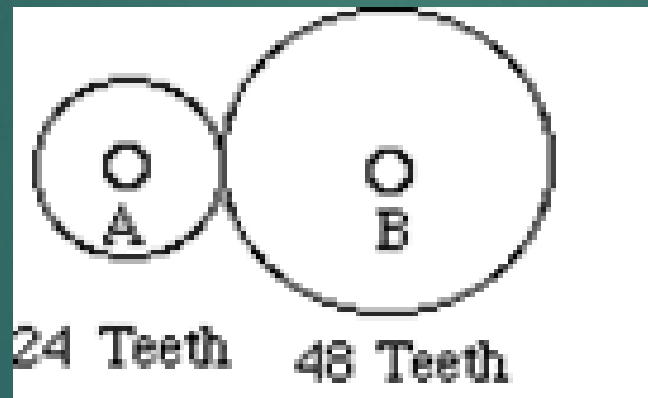

Figure 2-5 Gears

The gear that is closer to the source of power is called the *driver*, and the gear that receives power from the driver is called the *driven gear*.

Efficiency of Machines

In working out the problems on levers, belts and pulleys, inclined planes and so forth, we have not taken account of friction or other sources of energy loss. In other words, we have supposed them to be perfect, when in fact they are not. To measure the performance of a machine, we often find its efficiency, which is defined as

$$\eta = \frac{W_{\text{out}}}{W_{\text{in}}}$$

where

η = the efficiency of a machine,

W_{in} = the input work to a machine, and

W_{out} = the output work of a machine.

2.1 The Inclined Plane

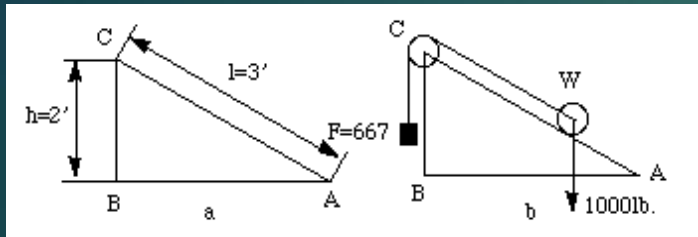

▶ 2.1.1 Screw Jack

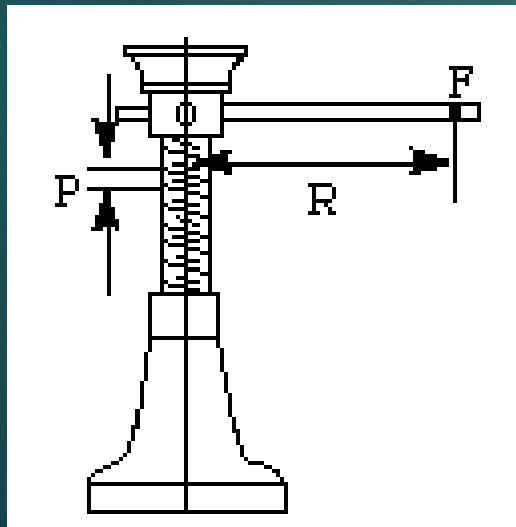

inclined plane is in the *screw jack*

$$F \times 2\pi R = W \times P$$

$$F = \frac{W \times P}{2\pi R}$$

2.2 Gears

One of the basic relationships for a gear is the number of teeth, the diameter, and the rotary velocity of gears.

- ▶ The gear that is closer to the source of power is called the **driver**, and the gear that receives power from the driver is called the **driven** gear.

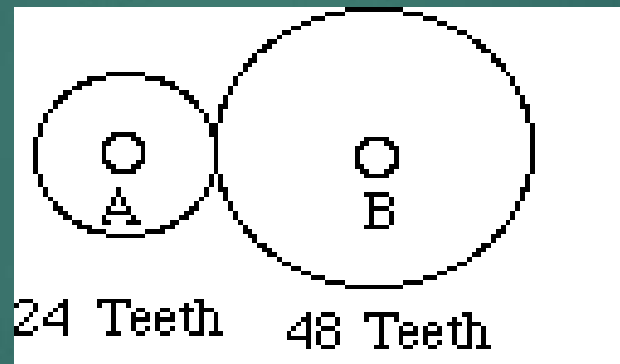

- ▶ The larger gear will make only one-half turn while the smaller makes a complete turn.
- ▶ That is, the ratio of speeds (velocity ratio) of the large to the smaller is as 1 to 2.

2.2.1 Gear Trains

A *gear train* may have several drivers and several driven gears.

- ▶ When gear A turns once clockwise, gear B turns 4 times counter-clockwise and gear C turns once clockwise. Hence gear B does not change the speed of C from what it would have been if geared directly to gear A, but it changes its direction from counterclockwise to clockwise.

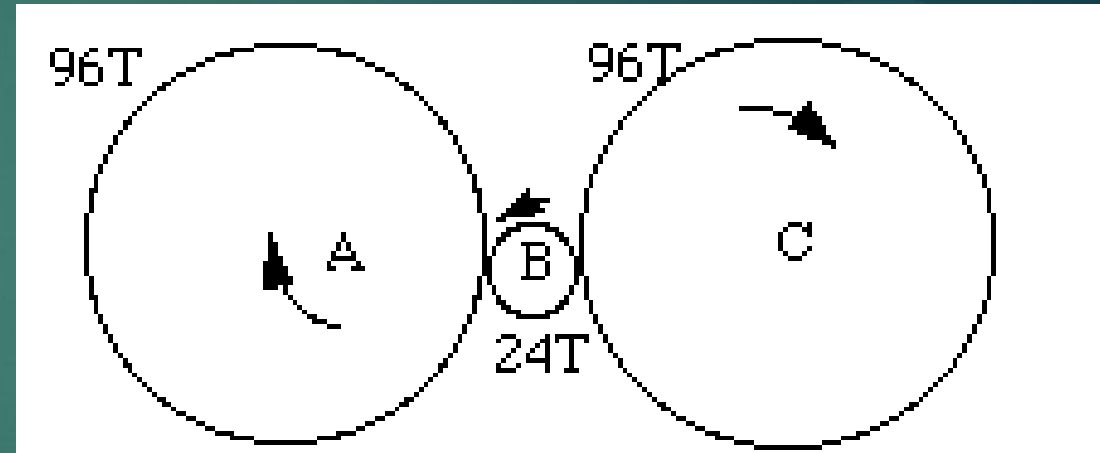

- ▶ The velocity ratio of the first and last gears in a train of simple gears does not change by putting any number of gears between them.

compound gears in which two gears are on the middle shaft

- ▶ Gears B and D rotate at the same speed since they are keyed (fixed) to the same shaft.

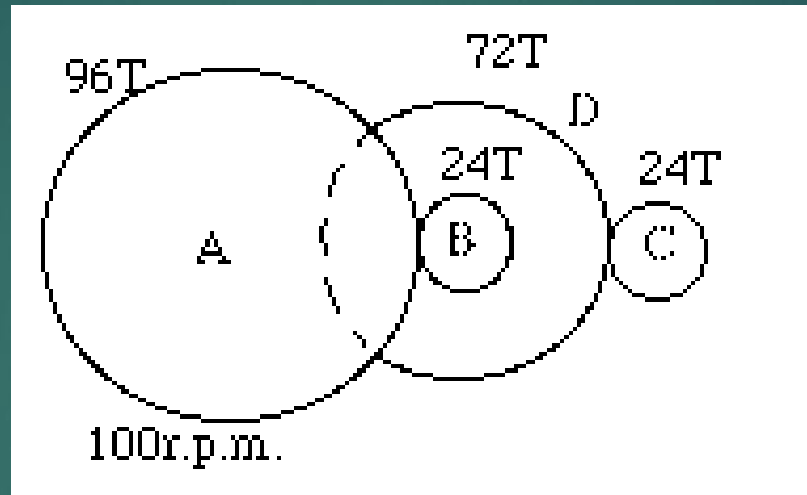

- ▶ if gear **A** rotates at 100 r.p.m. clockwise, gear **B** turns 400 r.p.m. (rotations per minute) counterclockwise and gear **C** turns 1200 r.p.m. clockwise.
- ▶ **2.2.2 Gear Ratios**
- ▶ It is important when working with gears to know what number of teeth the gears should have so that they can mesh properly in a gear train. The size of the teeth for connecting gears must be match properly.

2.3 Belts and Pulleys

- ▶ **Belts** and **pulleys** are an important part of most machines. **Pulleys** are nothing but gears without teeth and instead of running together directly they are made to drive one another by cords, ropes, cables, or belting of some kinds.
- ▶ As with gears, the velocities of pulleys are inversely proportional to their diameters.
- ▶ Pulleys can also be arranged as a block and tackle.

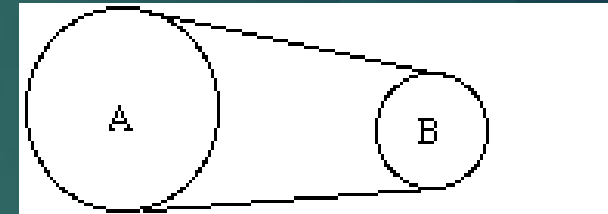

▶ 2.7 Efficiency of Machines

- ▶ In working out the problems on *levers, belts and pulleys, inclined planes* and so forth, we have not taken account of friction or other sources of energy loss. In other words, we have supposed them to be perfect, when in fact they are not. To measure the performance of a machine, we often find its **efficiency**, which is defined as:

η = the efficiency of a machine,
 W_{in} = the input work to a machine, and
 W_{out} = the output work of a machine.

$$\eta = \frac{W_{out}}{W_{in}}$$