

**IE-352**  
**Manufacturing Processes (2)**  
**Summer- 2013**  
**Lecture 5: Fundamentals of Machining**

**Dr Ashraf Afifi**  
**Industrial Engineering Department**  
**King Saud University**

# Outline

2

1. Introduction
2. Mechanics of Cutting
3. Cutting Forces and Power
4. Temperatures in Cutting
5. Tool Life: Wear and Failure
6. Surface Finish and Integrity
7. Machinability

# Introduction

3

- Cutting processes remove material from the surface of a workpiece by producing **chips**.

- Common cutting processes:

1. **Turning** (workpiece rotates; tool moves left, removes layer of material)

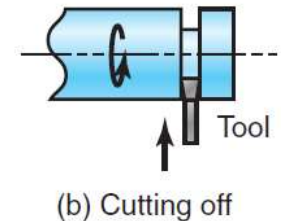
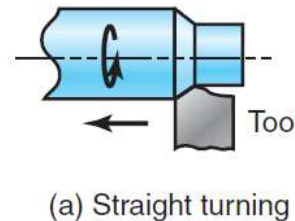

2. **Cutting off** (cutting tool moves radially inward).

3. **Slab milling**  
(rotating cutting tool removes material from workpiece).

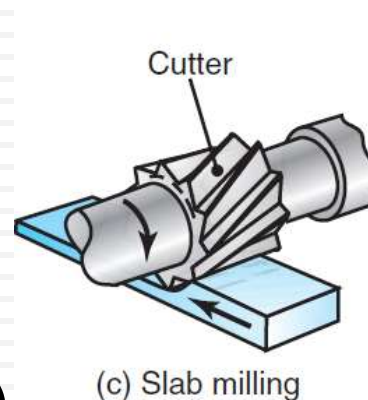

4. **End milling** (rotating cutter; produces cavity)

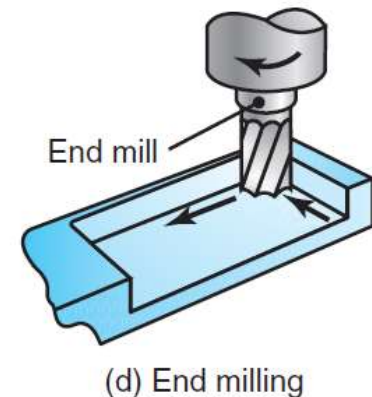

# Introduction

4

- In the **turning process**, the cutting tool is set at a certain *depth of cut* [mm] and travels to the left (with a certain velocity) as the workpiece rotates.
- *Feed*, or *feed rate*, is the distance the tool travels horizontally per unit revolution of the workpiece [mm/rev].

- This tool movement produces chips, which move up the face of the tool.

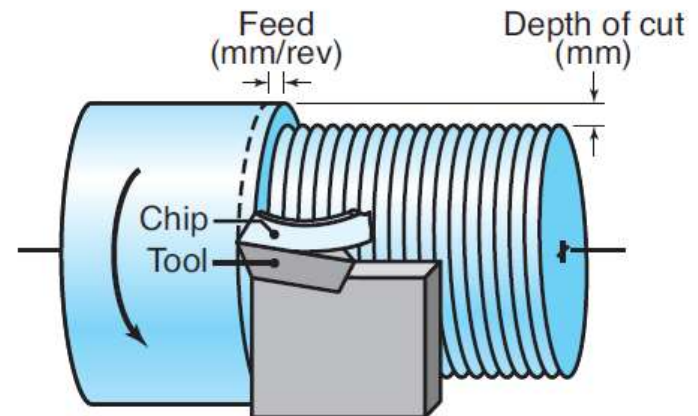

# Introduction

5

- In idealized model, a cutting tool moves to the left along the workpiece at a constant velocity,  $V$ , and a depth of cut,  $t_o$ .
- Chip thickness,  $t_c$

Idealized model; Orthogonal (2-D) cutting with a well-defined shear plane; also called M.E. Merchant model.

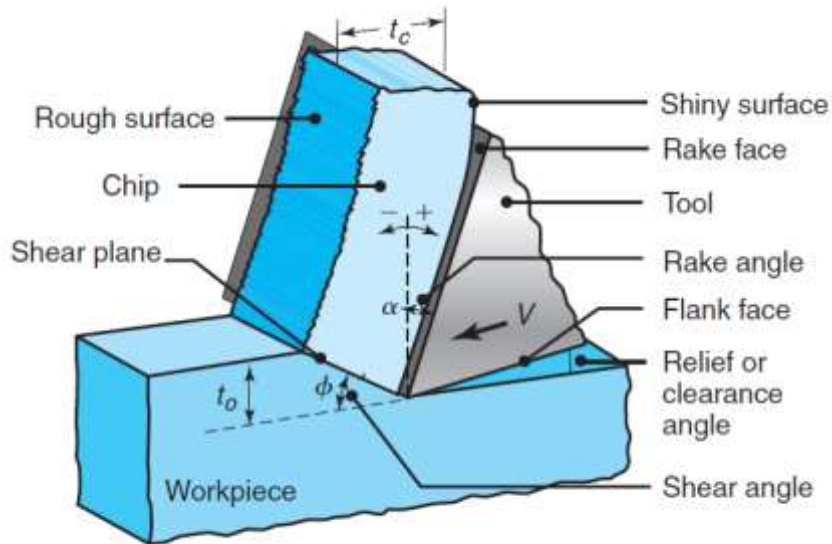

Orthogonal (2-D) cutting without a well-defined shear plane: "shear zone".

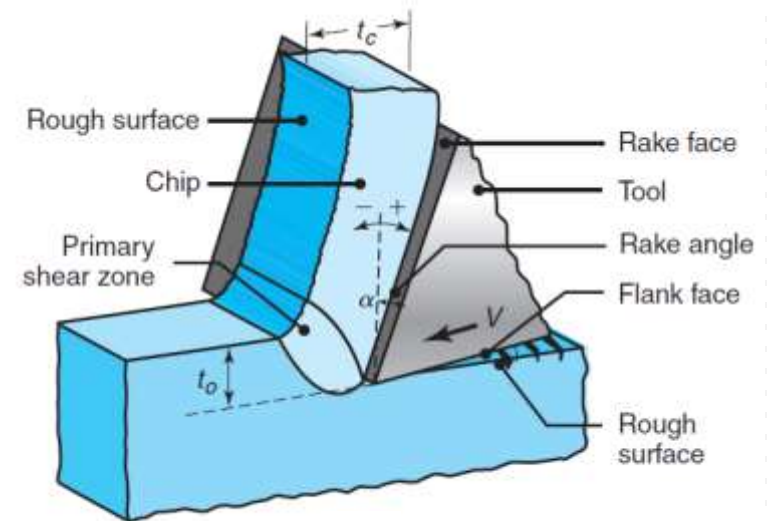

# Mechanics of Cutting

6

## Factors Influencing Machining Operations

Parameter	Influence and interrelationship
Cutting speed, depth of cut, feed, cutting fluids	Forces, power, temperature rise, tool life, type of chip, surface finish and integrity
Tool angles	As above; influence on chip flow direction; resistance to tool wear and chipping
Continuous chip	Good surface finish; steady cutting forces; undesirable, especially in automated machinery
Built-up edge chip	Poor surface finish and integrity; if thin and stable, edge can protect tool surfaces
Discontinuous chip	Desirable for ease of chip disposal; fluctuating cutting forces; can affect surface finish and cause vibration and chatter
Temperature rise	Influences tool life, particularly crater wear and dimensional accuracy of workpiece; may cause thermal damage to workpiece surface
Tool wear	Influences surface finish and integrity, dimensional accuracy, temperature rise, forces and power
Machinability	Related to tool life, surface finish, forces and power, and type of chip

# Mechanics of Cutting

7

- Major *independent variables* in the cutting process:
  1. Tool material and coatings,
  2. Tool shape, surface finish, and sharpness,
  3. Workpiece material and condition,
  4. Cutting speed, feed, and depth of cut,
  5. Cutting fluids,
  6. Characteristics of the machine tool,
  7. Work holding and fixturing.

# Mechanics of Cutting

8

- *Dependent variables* in cutting (influenced by changes in independent variables):
  1. Type of chip produced (studied since early 1940's),
  2. Force and energy dissipated during cutting,
  3. Temperature rise in the workpiece, the tool and the chip,
  4. Tool wear and failure,
  5. Surface finish and surface integrity of the work piece.

# Mechanics of Cutting

9

- Merchant model is known as **orthogonal cutting**.
- It is two dimensional and the forces involved are perpendicular to each other.
- Cutting tool has a **rake angle** of  $\alpha$  and a **relief** or **clearance angle**.
- Shearing takes place in a **shear zone** at a **shear angle**  $\phi$ .

Basic mechanism of chip formation by shearing

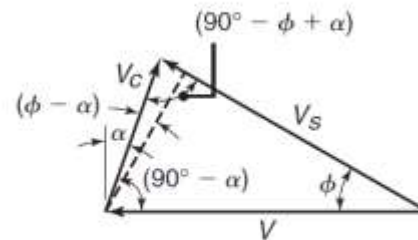
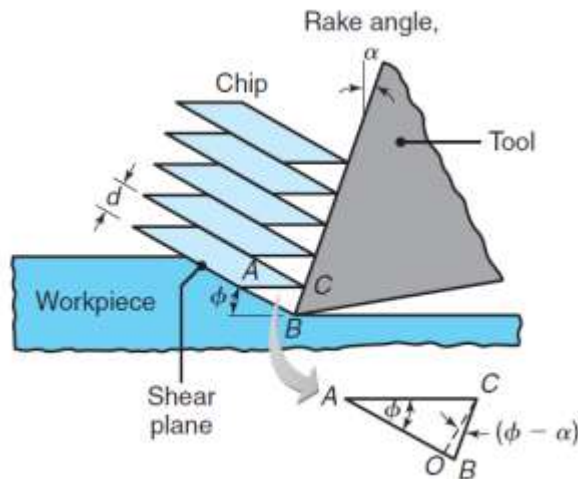

Velocity diagram showing angular relationship among 3 speeds in cutting zone:

$V$ : cutting speed

$V_s$ : shearing speed

$V_c$ : chip velocity

# Mechanics of Cutting

10

- Imagine shearing: “deck of cards” sliding along each other.
- Below shear plane, the workpiece is un-deformed.
- Above shear plane: the chip moves up the rake face.
- Dimension  $d$  (the distance between shear planes,  $OC$ ).
  - highly exaggerated to show mechanism
  - It is only in order of  $10^{-2}$  to  $10^{-3}$  mm
- Some materials shear in a zone (not plane).
  - e.g. cast iron
  - this leads to surface defects in workpiece

# Mechanics of Cutting

11

## Cutting Ratio (or chip-thickness ratio, $r$ )

- The ratio is related to the two angles
  - ▣ *shear angle,  $\phi$*
  - ▣ *rake angle,  $\alpha$*

$$\tan \phi = \frac{r \cos \alpha}{1 - r \sin \alpha} \Rightarrow r = \frac{t_0}{t_c} = \frac{\sin \phi}{\cos(\phi - \alpha)}$$

- Chip thickness  $t_c$  is always  $>$  than the depth of cut,  $t_0$ 
  - ▣  $\Rightarrow$  the value of  $r$  is always less than unity (i.e.  $<1$ ).
- Reciprocal of  $r$  (i.e.  $1/r$ ) is known as the *chip-compression ratio* or *chip-compression factor*.
  - ▣ It is a measure of how thick the chip has become,
  - ▣ Always  $> 1$ .

# Mechanics of Cutting

12

Making use of cutting ratio in evaluating cutting conditions:

- depth of cut,  $t_o$ : machine setting (i.e. independent variable).
- chip thickness,  $t_c$ , can be measured using a micrometer.
- cutting ratio,  $r$ , can then be easily calculated.
- rake angle,  $\alpha$ , is also known for a given cutting operation.
  - ▣ It is a function of the tool and workpiece geometry.
- Cutting ratio and rake angle can be used to find shear angle,  $\phi$  (equation in the [previous slide](#)).

# Mechanics of Cutting

13

## Shear Strain

- The **shear strain** (i.e. deformation relative to original size) that the material undergoes can be expressed as:

$$\gamma = \frac{AB}{OC} = \frac{AO}{OC} + \frac{OB}{OC} \Rightarrow \gamma = \cot \phi + \tan(\phi - \alpha)$$

- Large shear strains ( $\geq 5$ ) are associated with low shear angles or with low or negative rake angles.
- Based on the assumption that the shear angle adjusts itself to minimize the cutting force,

$$\phi = 45^\circ + \frac{\alpha}{2} - \frac{\beta}{2} \quad \begin{array}{l} \beta = \text{friction angle, related to } \mu : \\ \mu = \tan \beta \rightarrow \text{coefficient of friction} \end{array}$$

$$\Rightarrow \phi = 45^\circ + \alpha - \beta \quad (\text{when } \mu = 0.5 \sim 2) \quad \text{More general form}$$

# Mechanics of Cutting

14

- Chip encounters friction as it moves up the rake face.
- Large variations in contact pressure and temperature are encountered at the tool-chip interface (rake face).
- This causes big changes in  $\mu$  and it is thus called “apparent mean coefficient of friction”.
- Equation (first one in [previous slide](#)) thus indicates:
  - As rake angle  $\downarrow$  or friction at rake face  $\uparrow$   
 $\Rightarrow$  shear angle  $\downarrow$  and chip becomes thicker.
  - Thicker chip  $\Rightarrow$  more energy lost because shear strain is higher.
  - Because work done during cutting is converted into heat  $\Rightarrow$  temperature rise is higher.

# Mechanics of Cutting

15

## Velocities in the Cutting Zone

- Since  $t_c > t_o \Rightarrow V_c$  (velocity of chip)  $< V$  (cutting speed)
- Since mass continuity is maintained,

$$Vt_0 = V_c t_c \text{ or } V_c = Vr \Rightarrow V_c = \frac{V \sin \phi}{\cos(\phi - \alpha)}$$

- From the *Velocity diagram*, the following equation can be obtained using trigonometric relationships ( $V_s$  velocity at shearing plane):

$$\frac{V}{\cos(\phi - \alpha)} = \frac{V_s}{\cos \alpha} = \frac{V_c}{\sin \phi}$$

- Note also that

$$r = \frac{t_0}{t_c} = \frac{V_c}{V}$$

# Mechanics of Cutting:

## Types of Chips Produced in Metal Cutting

16

- Types of metal chips commonly observed in practice (orthogonal metal cutting)
- There are 4 main types:

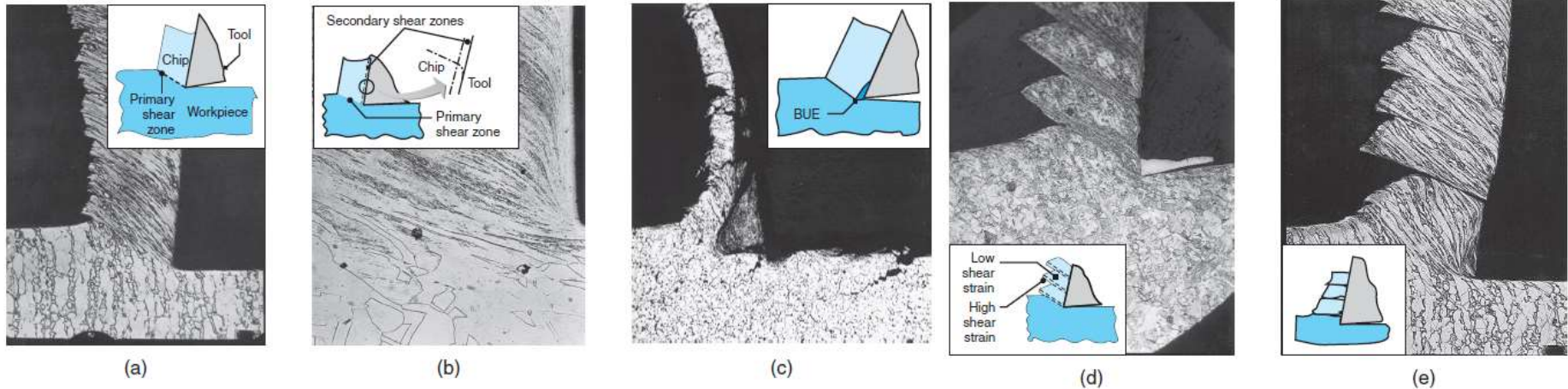

- Continuous chip (with narrow, straight, primary shear zone),
- Continuous chip with secondary shear zone at the tool-chip interface,
- Built-up edge, BUE chip,
- Serrated or segmented or non-homogenous chip,
- Discontinuous chip.

# Mechanics of Cutting:

## Types of Chips Produced in Metal Cutting

17

### All Chips

- Chip has two surfaces:
  - Surface in contact with the rake face.
    - Shiny and polished,
    - Caused by rubbing of the chip on the tool surface.
  - Outer surface from the original surface of the workpiece.
    - Jagged, rough appearance,
    - Caused by shearing mechanism,
    - Note, this surface remains exposed to the environment, and does not come into contact with any other surface.

# Mechanics of Cutting:

## Types of Chips Produced in Metal Cutting

18

### Continuous Chips

- Formed with ductile materials machined at high cutting speeds and/or high rake angles.
- Deformation takes place along a narrow shear zone called the (*primary shear zone*).
- Continuous chips may develop a *secondary shear zone* due to high friction at the tool-chip interface.
  - This zone becomes thicker as friction increases.
- Continuous chips may also occur with wide primary shear zone with curved boundaries.
  - Note, lower boundary of deformation zone drops below machined surface ⇒ distortion in workpiece, poor finish.
  - Occurs: machining soft metals at low speeds, low rake angles.

# Mechanics of Cutting:

## Types of Chips Produced in Metal Cutting

19

### Built-up Edge (BUE) Chips

- Consists of layers of material from the workpiece that are deposited on the tool tip.
- As it grows larger, the BUE becomes unstable and eventually breaks apart.
- BUE can be reduced by:
  1. Increase the cutting speeds,
  2. Decrease the depth of cut,
  3. Increase the rake angle,
  4. Use a sharp tool,
  5. Use an effective cutting fluid,
  6. Use cutting tool with lower chemical affinity than workpiece material.

Hardness distribution with BUE chip  
note BUE chip much harder than chip

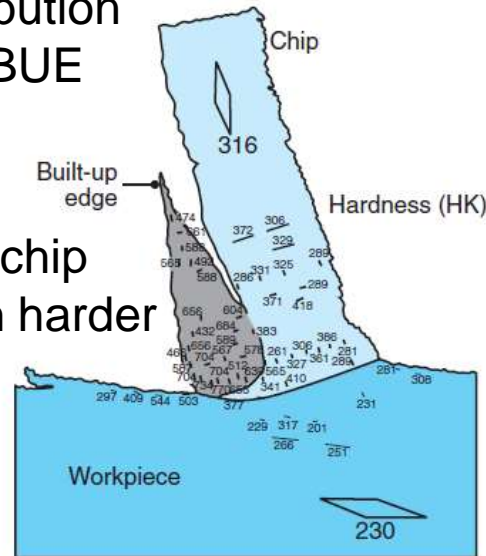

BUE: turning

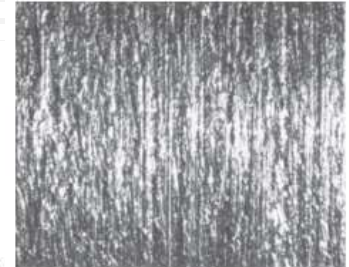

BUE: milling



# Mechanics of Cutting:

## Types of Chips Produced in Metal Cutting

20

### Serrated Chips

- Also called *segmented* or *nonhomogeneous* chips
- They are semicontinuous chips with
  - large zones of low shear strain and,
  - small zones of high shear strain (*shear localization*).
- Example: metals with low thermal conductivity and strength that decreases sharply with temperature, i.e. thermal softening (e.g. titanium).
- Chips have a sawtooth-like appearance

# Mechanics of Cutting:

## Types of Chips Produced in Metal Cutting

21

### Discontinuous Chips

- Consist of segments that are attached firmly or loosely to each other.
  
- Form under the following conditions:
  1. Brittle workpiece materials,
  2. Materials with hard inclusions and impurities,
  3. Very low or very high cutting speeds,
  4. Large depths of cut,
  5. Low rake angles,
  6. Lack of an effective cutting fluid,
  7. Low stiffness of the machine tool ( $\Rightarrow$  vibration, chatter).

# Mechanics of Cutting:

## Types of Chips Produced in Metal Cutting

22

### Chip Curl

- Chips will develop a curvature (*chip curl*) as they leave the workpiece surface.
  
- Factors affecting the chip curl conditions are:
  1. Distribution of stresses in the primary and secondary shear zones,
  2. Thermal effects,
  3. Work-hardening characteristics of the workpiece material,
  4. Geometry of the cutting tool,
  5. Cutting fluids.
  
- Note, as cutting depth ↓, chip radius ↓.

# Mechanics of Cutting:

## Types of Chips Produced in Metal Cutting

23

### Chip Breakers

- Long, continuous chips are undesirable since:
  - ▣ become entangled and greatly interfere with machining,
  - ▣ potential safety hazard.

- *chip-breaker*: breaks chips intermittently with cutting tools.
- Traditionally are clamped to rake face: bend and break the chip.
- Modern tools: built-in chip breakers.
- Ideal chip: “C” or “9” shape.

action of chip breaker

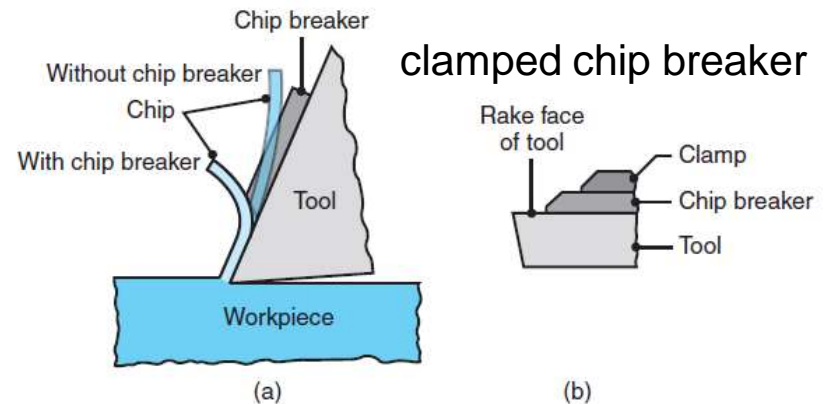

Grooves in tools act as chip breakers

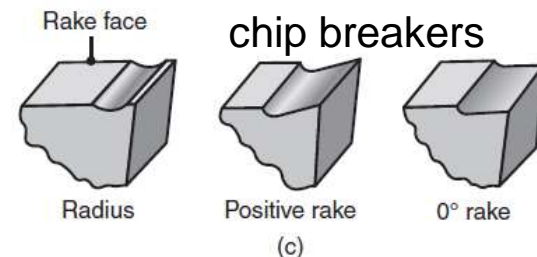

# Mechanics of Cutting:

## Types of Chips Produced in Metal Cutting

24

### Chip Breakers

- Chips can also be broken by changing the tool geometry to control chip flow.

#### Chips produced in turning



(a)

Tightly curled chip

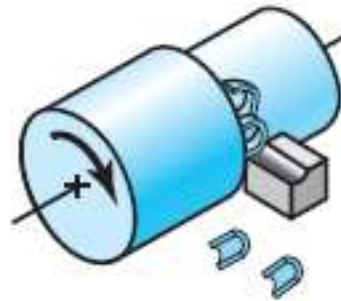

(b)

Chip hits workpiece  
and breaks

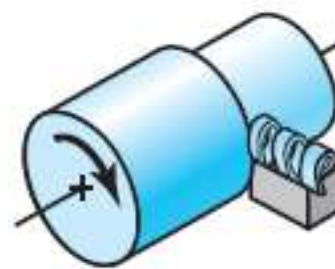

(c)

Continuous chip  
moving radially  
away from the  
workpiece

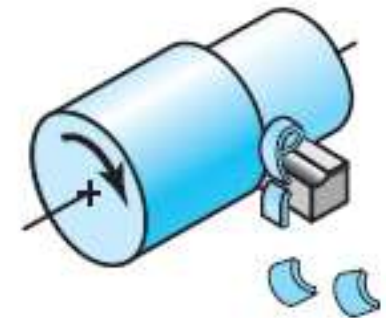

(d)

Chip hits tool  
shank (body) and  
breaks off

# Mechanics of Cutting:

## Oblique Cutting

25

- Majority of machining operations involve tool shapes that are 3-D where the cutting is said to be *oblique*.
- Difference between oblique and orthogonal cutting can be seen in chip movement and shape.

**Cutting with an Oblique Tool**  
(note the direction of chip movement)

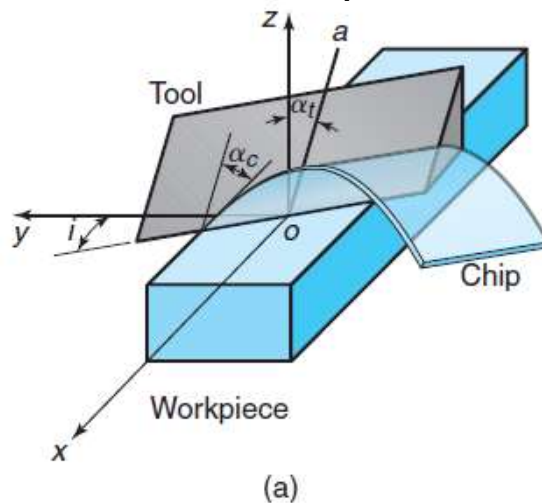

Top view, showing inclination angle,  $i$

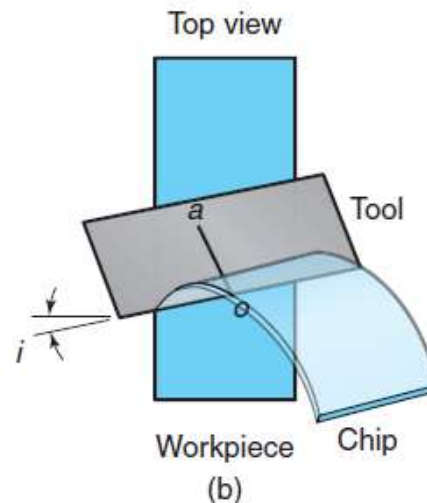

Types of chips produced with tools at increasing inclination angles

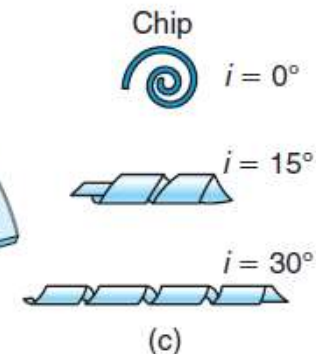

# Mechanics of Cutting:

## Oblique Cutting

26

- Orthogonal cutting: chip slides directly up face of the tool.
  
- Oblique cutting: chip is *helical*, at an **inclination angle**.
  - Chip movement is like snow from snowplow blade: sideways.
  
  - i.e. helical chip does not interfere with the cutting zone, unlike orthogonal cutting.
  
  - As  $i \uparrow \Rightarrow$  chip becomes thinner and longer (see [last slide](#))  
 $\Rightarrow$  cutting force  $\downarrow$ .

# Mechanics of Cutting:

## Oblique Cutting

27

### Shaving and Skiving

- Thin layers of material can be removed from straight or curved surfaces (similar to shaving wood with a plane).
- *Shaving* can improve the surface finish and dimensional accuracy.
- Parts that are long or have a combination of shapes are shaved by *skiving*.
  - A specially shaped cutting tool is moved tangentially across the length of the workpiece.

# Cutting Forces and Power

28

- Knowledge of *cutting forces* and *power* involves:
  1. Data on cutting forces
    - ▣ important to minimize distortions, maintain required dimensional accuracy, help select appropriate toolholders.
  2. Power requirements
    - ▣ enable appropriate tool selection.

**Forces acting in the cutting zone during 2-D (orthogonal) cutting**

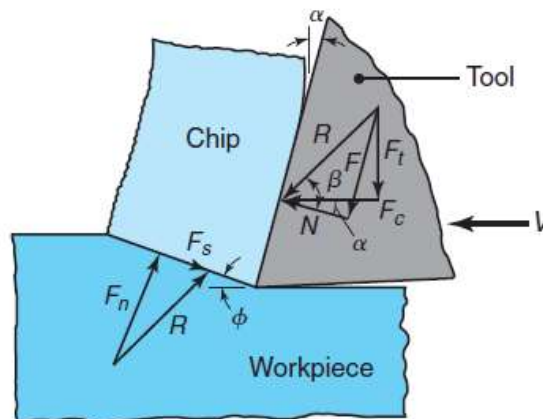

(a)

**Force circle to determine various forces in cutting zone**

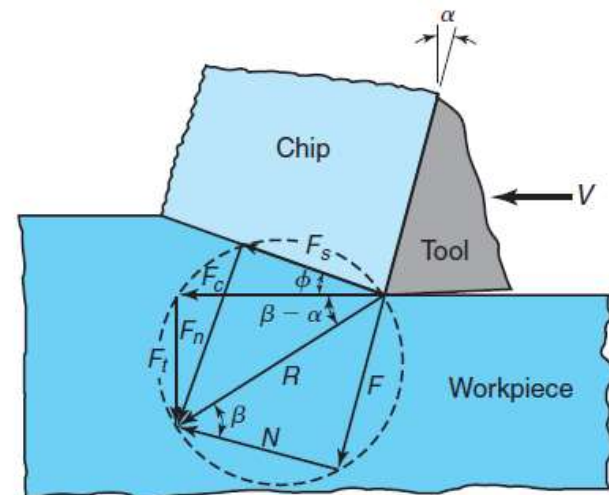

(b)

# Cutting Forces and Power

29

- Forces considered in orthogonal cutting include:
  - ▣ Cutting, friction (tool face), and shear forces.
- **Cutting force**,  $F_c$ , acts in the direction of the cutting speed  $V$ , and supplies the energy required for cutting.
  - ▣ Ratio of  $F_c$  to cross-sectional area being cut (i.e. product of width and depth of cut,  $t_0$ ) is called: *specific cutting force*.
- **Thrust force**,  $F_t$ , acts in a direction normal to the cutting force.
- These two forces produces the **resultant force**,  $R$ 
  - ▣ see force circle ([last slide](#))
- On the tool face, the resultant force can be resolved into:
  - ▣ **Friction force**,  $F$  along the tool-chip interface,
  - ▣ **Normal force**,  $N$  to  $\perp$  to friction force.

# Cutting Forces and Power

30

- It can also be shown that ( $\beta$  is the friction angle):

$$F = R \sin \beta \Rightarrow N = R \cos \beta$$

- Resultant force,  $R$  is balanced by an equal and opposite force along the shear plane.

- It is resolved into **shear force**,  $F_s$  and **normal force**,  $F_n$

- Thus, 
$$F_s = F_c \cos \phi - F_t \sin \phi$$

$$F_n = F_c \sin \phi + F_t \cos \phi$$

- The magnitude of the **coefficient of friction**,  $\mu$ , is

$$\mu = \frac{F}{N} = \frac{F_t + F_c \tan \alpha}{F_c - F_t \tan \alpha}$$

# Cutting Forces and Power

31

## Thrust Force

- The toolholder, the work-holding devices, and the machine tool must be stiff to support the thrust force with minimal deflections.
  - If  $F_t$  is too high  $\Rightarrow$  the tool will be pushed away from the workpiece.
  - this will reduce depth of cut and dimensional accuracy.

- The effect of rake angle and friction angle on the direction of thrust force is

$$F_t = R \sin(\beta - \alpha) \text{ or } F_t = F_c \tan(\beta - \alpha)$$

- The magnitude of the cutting force,  $F_c$ , is always positive as it is the force that supplies the work required in cutting.
- However,  $F_t$  can be +ve or -ve; i.e.  $F_t$  can be upward (that is -ve) with a) high rake angle, b) low tool-chip friction, or c) both.

# Cutting Forces and Power

32

## Power

- The power input in cutting is

$$Power = F_c V$$

- Power is dissipated in
  - ▣ shear plane/zone (due to the energy required to shear material).
  - ▣ Rake face (due to the tool-chip interface friction).

- Power dissipated in shearing is

$$Power \text{ for shearing} = F_s V_s$$

- Denoting the width of cut as  $w$ , (i.e. area of cut:  $wt_0$ ), the **specific energy for shearing**, is

$$u_s = \frac{Power \text{ for shearing}}{Material \text{ removal rate}} = \frac{F_s V_s}{wt_0 V}$$

# Cutting Forces and Power

33

## Power

- The power dissipated in friction is

$$\text{Power for friction} = FV_c$$

- The **specific energy for friction,  $u_f$** , is

$$u_f = \frac{\text{Power of friction}}{\text{Material removal rate}} = \frac{FV_c}{wt_0V} = \frac{Fr}{wt_0}$$

- **Total specific energy,  $u_t$** , is

$$u_t = u_s + u_f$$

# Cutting Forces and Power

34

## Power

- Prediction of forces is based largely on the experimental data.
- Wide ranges of values is due to differences in material strengths.
- Sharpness of the tool tip also influences forces and power.
- Duller tools require higher forces and power.

**Approximate Range of Energy Requirements in Cutting Operations at the Drive Motor of the Machine Tool (for Dull Tools, Multiply by 1.25)**

Material	Specific energy $W \cdot s/mm^3$
Aluminum alloys	0.4–1
Cast irons	1.1–5.4
Copper alloys	1.4–3.2
High-temperature alloys	3.2–8
Magnesium alloys	0.3–0.6
Nickel alloys	4.8–6.7
Refractory alloys	3–9
Stainless steels	2–5
Steels	2–9
Titanium alloys	2–5

# Cutting Forces and Power

35

## Measuring Cutting Forces and Power

- Cutting forces can be measured using a **force transducer**, a **dynamometer** or a **load cell** mounted on the cutting-tool holder.
- It is also possible to calculate the cutting force from the **power consumption** during cutting (provided that the mechanical efficiency of the machine tool can be determined).
- The *specific energy* in cutting can also be used to calculate cutting forces.

# Cutting Forces and Power

36

## EXAMPLE 1:

### Relative Energies in Cutting

In an orthogonal cutting operation,  $t_o = 0.13$  mm,  $V = 120$  m/min,  $\alpha = 10^\circ$  and the width of cut 6 mm. It is observed that  $t_c = 0.23$  mm,  $F_c = 500$  N and  $F_t = 200$  N. Calculate the percentage of the total energy that goes into overcoming friction at the tool–chip interface.

# Cutting Forces and Power

37

## Solution

The percentage of the energy can be expressed as

$$\frac{\text{Friction Energy}}{\text{Total Energy}} = \frac{FV_c}{F_c V} = \frac{Fr}{F_c}$$

where

$$r = \frac{t_0}{t_c} = \frac{0.13}{0.23} = 0.565$$

We have

$$F = R \sin \beta, \quad F_c = R \cos(\beta - \alpha) \quad \text{and}$$

$$R = \sqrt{(F_t^2 + F_c^2)} = \sqrt{200^2 + 500^2} = 539 \text{ N}$$

# Cutting Forces and Power

38

Thus,

$$500 = 539 \cos(\beta - 10) \Rightarrow \beta = 32^\circ$$

$$F = 539 \sin 32^\circ = 286 \text{ N}$$

Hence

$$\text{Percentage} = \frac{(286)(0.565)}{500} = 0.32 \text{ or } 32\%$$

# Temperatures in Cutting

39

- The major adverse effects of the **temperature rise** in the cutting zone (due to heat lost in cutting) are:
  1. Lower strength, hardness, stiffness and wear resistance of the cutting tool (i.e. alters tool shape),
  2. Uneven dimensional changes (machined parts), and
  3. Thermal damage and metallurgical changes in the machined surface ( $\Rightarrow$  properties adversely affected).
  
- **Sources of heat** in machining:
  1. Work done in shearing (primary shear zone),
  2. Energy lost due to friction (tool-chip interface), and
  3. Heat generated due to the tool rubbing on the machined surface (especially dull or worn tools).

# Temperatures in Cutting

40

- Expression: *mean temperature* in orthogonal cutting:

$$T = \frac{0.000665Y_f}{\rho c} \sqrt[3]{\frac{Vt_0}{K}}$$

where,

- $T$ : (also called  $T_{mean}$ ) mean temperature in [k].
- $Y_f$ : flow stress in [MPa], [1 Pa = 1 N/m<sup>2</sup>], [1 N = 1 kg.m/s<sup>2</sup>].
- $\rho c$ : volumetric specific heat in [J/m<sup>3</sup>.k],  $\rho$ : density [kg/m<sup>3</sup>],  $c$ : specific heat (the amount of heat per unit mass required to raise the temperature by one degree kelvin) [J/kg.k], [1 J = 1 N.m].
- $K$ : thermal diffusivity (ratio of thermal conductivity (the material ability to conduct heat) [J/m.k.s] to volumetric specific heat) [m<sup>2</sup>/s].
- Equation shows that  $T$ :
  - increases with workpiece material strength, cutting speed ( $V$ ), depth of cut ( $t_0$ ),
  - decreases with  $\rho c$  and  $K$ .

# Temperatures in Cutting

41

- *Mean temperature in turning on a lathe is given by*

$$T_{mean} \propto V^a f^b$$

where,

- $V$ : cutting speed
- $f$ : feed of the tool
- Approximate values of the exponents  $a$ ,  $b$ :
  - *Carbide tools*:  $a = 0.2$ ,  $b = 0.125$
  - *High-speed steel tools*:  $a = 0.5$ ,  $b = 0.375$
- Also note how this relation shows the increase in temperature with increased cutting speed and feed.

# Temperatures in Cutting

42

## Temperature Distribution

- Sources of heat generation are concentrated in
  - ▣ primary shear zone, and
  - ▣ At tool-chip interface.
  
- Note *maximum temperature* is about halfway up tool-chip interface.

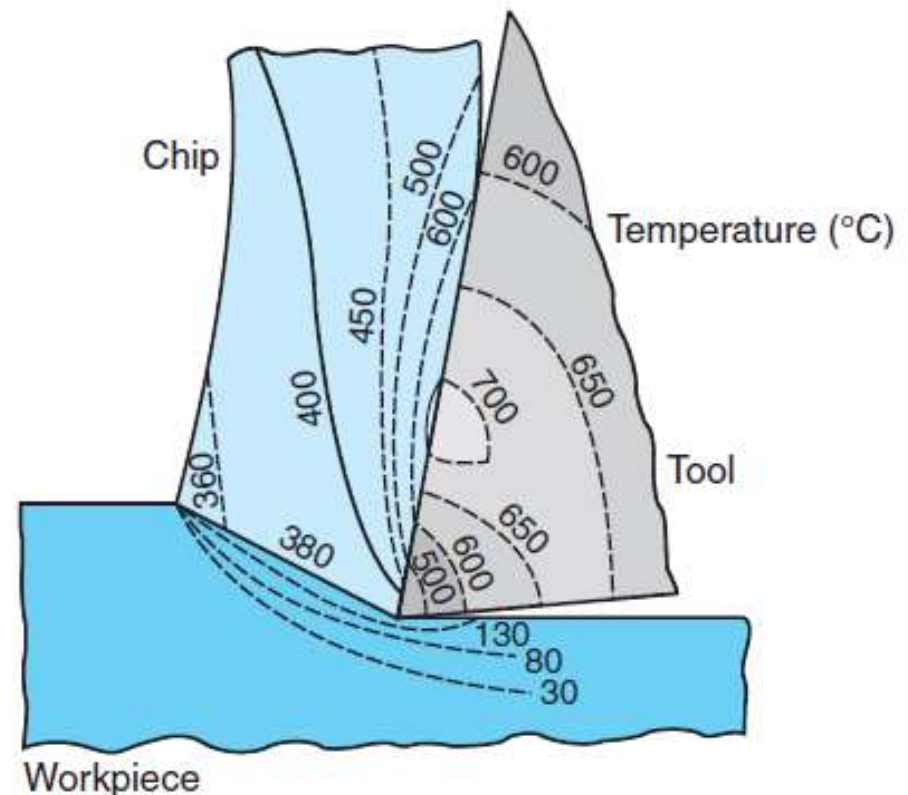

# Temperatures in Cutting

43

## Temperature Distribution

Note:

- Highest temperature:  $1100^{\circ}\text{C}$

- High temperature appears as dark-color on chips (by oxidation at high  $V$ )

- Reason: as  $V \uparrow \Rightarrow$  time for heat dissipation  $\downarrow \Rightarrow$  temperature  $\uparrow$

Temperatures developed in turning 52100 steel

a) flank temperature distribution

b) tool-chip interface temp. distribution (note, 0: tool tip; 1: end of tool-chip contact)

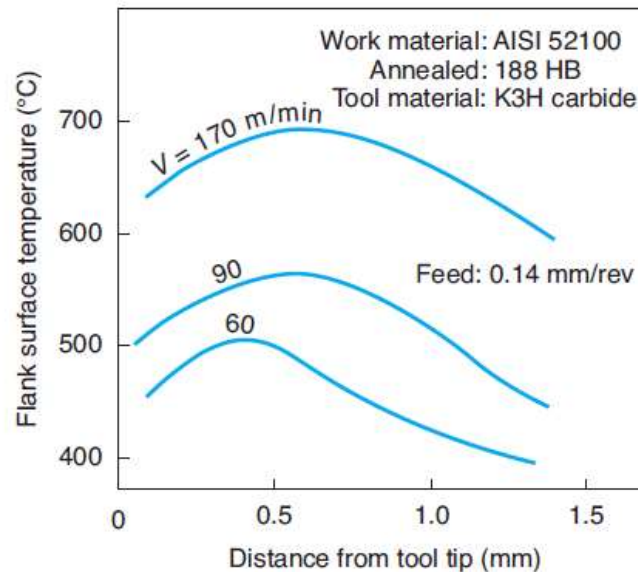

(a)

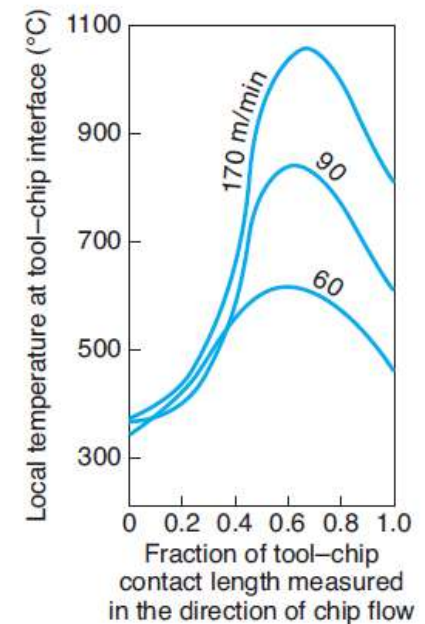

(b)

# Temperatures in Cutting

44

## Temperature Distribution

- The temperature increases with cutting speed.
- Chips can become red hot and create a safety hazard for the operator.
- The chip carries away most (90%) of the heat generated during machining (see the accompanying figure).
  - Rest carried by tool and workpiece.
- Thus, high machining speed ( $V$ )  $\Rightarrow$ 
  1. More energy lost in chips,
  2. Machining time decreases (i.e. favorable machining economics).

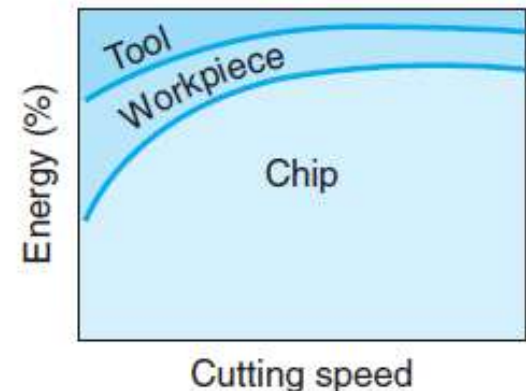

# Temperatures in Cutting

45

## Techniques for Measuring Temperature

- Temperatures and their distribution can be determined using:
  - ▣ **thermocouples** (placed on tool or workpiece),
  - ▣ Electromotive force at the tool-chip interface,
  - ▣ Measuring **infrared radiation** (using a *radiation pyrometer*) from the cutting zone (only measures surface temperatures).

# Tool Life: Wear and Failure

46

- **Tool wear** is a gradual process; created due to:
  1. High localized stresses at the tip of the tool,
  2. High temperatures (especially along the rake face),
  3. Sliding of the chip along the rake face,
  4. Sliding of the tool along the newly cut workpiece surface.
  
- The rate of tool wear depends on:
  1. tool and workpiece materials,
  2. tool geometry,
  3. process parameters,
  4. cutting fluids,
  5. characteristics of the machine tool.

# Tool Life: Wear and Failure

47

- Tool wear and the changes in tool geometry are classified as:
  1. *Flank wear,*
  2. *Crater wear,*
  3. *Nose wear,*
  4. *Notching,*
  5. *Plastic deformation of the tool tip,*
  6. *Chipping and Gross fracture.*

# Tool Life: Wear and Failure

a) Features of tool wear in a turning operation. **VB**: indicates average flank wear

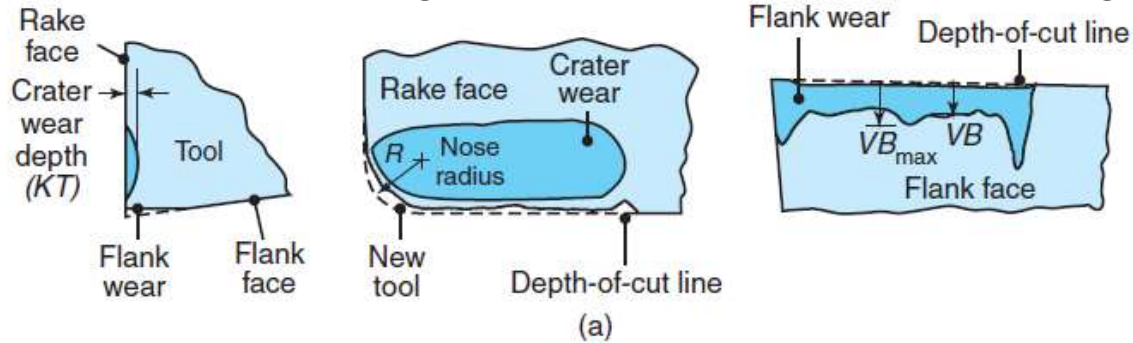

b) – e) Examples of wear in cutting tools

b) Flank wear

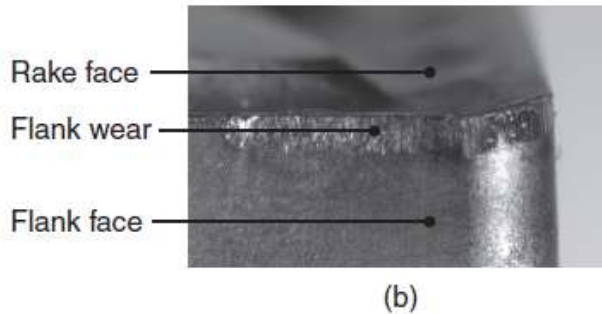

c) Crater wear

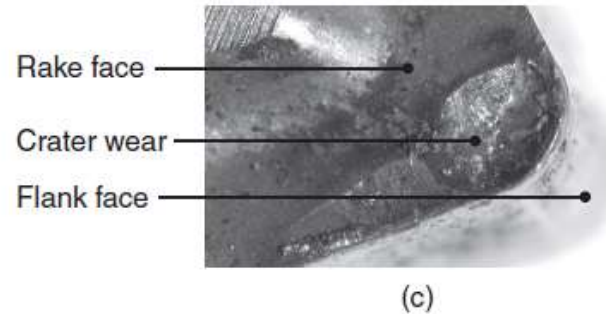

d) Thermal cracking

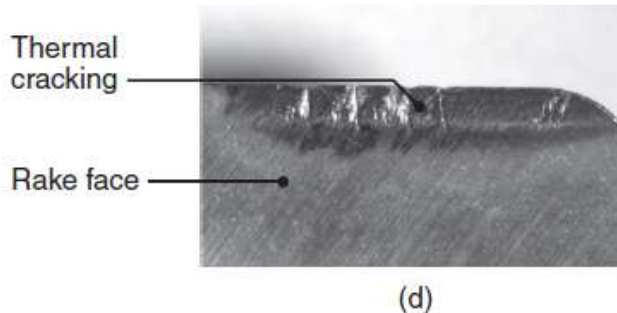

e) Flank wear and built-up edge (**BUE**)

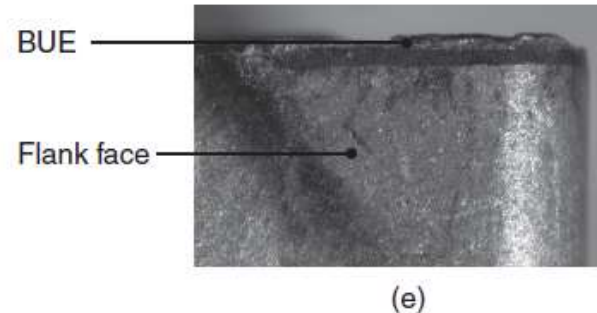

# Tool Life: Wear and Failure:

## Flank Wear

49

- Flank wear occurs on the relief (flank) face of the tool
- It is due to
  - ▣ rubbing of the tool along machined surface ( $\Rightarrow$  adhesive/abrasive wear)
  - ▣ high temperatures (adversely affecting tool-material properties)

- ***Taylor tool life equation :***

$$VT^n = C$$

$V$  = cutting speed [ $m/minute$ ].

$T$  = time [ $minutes$ ] taken to develop a certain flank **wear land** ( $V_B$ , [last slide](#)).

$n$  = an exponent that generally depends on the tool material (see the above table).

$C$  = constant; depends on cutting conditions.

Note, magnitude of  $C$  = cutting speed at  $T = 1$  min.

Also note:  $n, c$  : determined experimentally.

Ranges of  $n$  Values for the Taylor Equation for Various Tool Materials

High-speed steels	0.08–0.2
Cast alloys	0.1–0.15
Carbides	0.2–0.5
Coated carbides	0.4–0.6
Ceramics	0.5–0.7

# Tool Life: Wear and Failure:

## Flank Wear

50

- To appreciate the importance of the exponent,  $n$ , *Taylor tool life equation*, rearranged:

$$T = \left( \frac{C}{V} \right)^{1/n}$$

- Thus, for constant  $C$ : smaller  $n \Rightarrow$  smaller tool life.
- For turning, equation can be modified to

$$VT^n d^x f^y = C$$

where,

$d$  = depth of cut (same as  $t_0$ ).

$f$ : feed of the tool [ $mm/rev$ ].

$x, y$ : must be determined experimentally for each cutting condition.

# Tool Life: Wear and Failure:

## Flank Wear

51

- Typical values in machining conditions:
  - ▣  $n = 0.15$ ;  $x = 0.15$ ;  $y = 0.6$ .
  - ▣ i.e. decreasing importance order:  $V$ , then  $f$ , then  $d$ .

- Equation can be rearranged as

$$T = C^{1/n} V^{-1/n} d^{-x/n} f^{-y/n}$$

- Substituting typical values  $\Rightarrow$

$$T \approx C^7 V^{-7} d^{-1} f^{-4}$$

- To obtain a constant tool life:
  1. Decrease  $V$  if  $f$  or  $d$  are increased (and vice versa).
  2. Depending on the exponents, if  $V \downarrow \Rightarrow$  you can increase volume of material removed by  $\uparrow f$  or  $d$ .

# Tool Life: Wear and Failure:

## Flank Wear

52

### Tool-life Curves

- *Tool-life curves* are plots of experimental data from performing cutting tests on various materials under different cutting conditions (e.g.  $V$ ,  $f$ ,  $t_0$ , tool material,...).
- Note (figure below)
  - ▣ As  $V$  increases  $\Rightarrow$  tool life decreases very fast.
  - ▣ Condition of workpiece material has large impact on tool life.
  - ▣ There is large difference in tool life among different compositions.

Effect of workpiece hardness and microstructure on tool life in turning ductile cast iron. Note the rapid decrease in tool life (approaching zero as  $V$  increases).

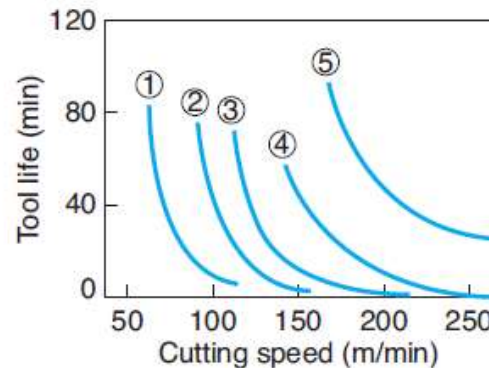

	Hardness (HB)	Ferrite	Pearlite
① As cast	265	20%	80%
② As cast	215	40	60
③ As cast	207	60	40
④ Annealed	183	97	3
⑤ Annealed	170	100	—

# Tool Life: Wear and Failure:

## Flank Wear

53

### Tool-life Curves

- The exponent  $n$  can be determined from tool-life curves (see the figure below):
  - smaller  $n$  value  $\Rightarrow$  as  $V$  increases  $\Rightarrow$  tool life decreases faster.
  - $n$  can be negative at low cutting speeds.
- Temperature also influences wear:
  - as temperature increases, flank wear rapidly increases.

Tool-life curves for a variety of cutting-tool materials. The negative reciprocal of the slope of these curves is the exponent  $n$  in the Taylor tool-life Equation, and  $C$  is the cutting speed at  $T = 1$  min, ranging from about 60 to 3,000 m/min in this figure.

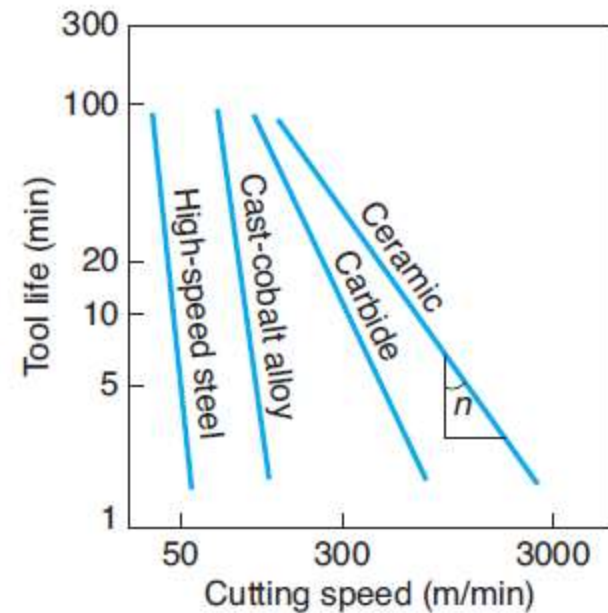

# Tool Life: Wear and Failure:

## Flank Wear

54

### EXAMPLE 2:

#### Increasing Tool Life by Reducing the Cutting Speed

Using the Taylor Equation for tool life and letting  $n = 0.5$  and  $C = 120$ , calculate the percentage increase in tool life when the cutting speed is reduced by 50%.

#### Solution:

Since  $n = 0.5$ , we have  $0.5V_1\sqrt{T_2} = V_1\sqrt{T_1} \Rightarrow \frac{T_2}{T_1} = 4$

This indicates that the change in tool life is

$$\frac{T_2 - T_1}{T_1} = \left( \frac{T_2}{T_1} \right) - 1 = 3 \text{ or } 300\% \text{ increase}$$

# Tool Life: Wear and Failure:

## Flank Wear

55

### Allowable Wear Land (average flank wear, $VB$ )

- Cutting tools need to be replaced/resharpened when:
  1. Surface finish of the machined workpiece begins to deteriorate.
  2. Cutting forces increase significantly.
  3. Temperature rises significantly.

- $VB$  values for various machining conditions: ⇒

- Note,  $VB$  should be smaller than these values for higher dimensional accuracy, tolerances, surface finish.

Operation	Allowable wear land (mm)	
	High-speed steel tools	Carbide tools
Turning	1.5	0.4
Face milling	1.5	0.4
End milling	0.3	0.3
Drilling	0.4	0.4
Reaming	0.15	0.15

*Note:* Allowable wear for ceramic tools is about 50% higher. Allowable notch wear,  $VB_{\max}$ , is about twice that for  $VB$ .

# Tool Life: Wear and Failure:

## Flank Wear

56

### Allowable Wear Land

- Recommended cutting speed is one producing tool life:
  - 60-120 min: high-speed steel tools
  - 30-60 min: carbide tools
  
- Note, with pc-controlled machine tools, values can vary significantly from those mentioned above.

### Optimum Cutting Speed

- Optimum cutting speed is a tradeoff between:
  1. Cutting speed ( $V$ ), since as  $V \uparrow$ , tool life quickly  $\downarrow$ .
  2. Material removal rate, since as  $V \downarrow$ , tool life  $\uparrow$ , but material removal rate also  $\downarrow$ .

# Tool Life: Wear and Failure:

## Flank Wear

57

### EXAMPLE 3:

#### Effect of Cutting Speed on Material Removal

- When cutting speed is 60 m/min, tool life is 40 min.
- The tool travels a distance of  $60 \times 40 = 2400$  m.
- When cutting speed is increased to 120 m/min, tool life reduced to 5 min and travels 600 m.
- Since the volume of material removed is directly proportional to the distance the tool has traveled, it can be seen that by *decreasing* the cutting speed, *more* material is removed between tool changes.

# Tool Life: Wear and Failure: Crater Wear

58

- *Crater wear* occurs on the rake face of the tool (see slide 48)

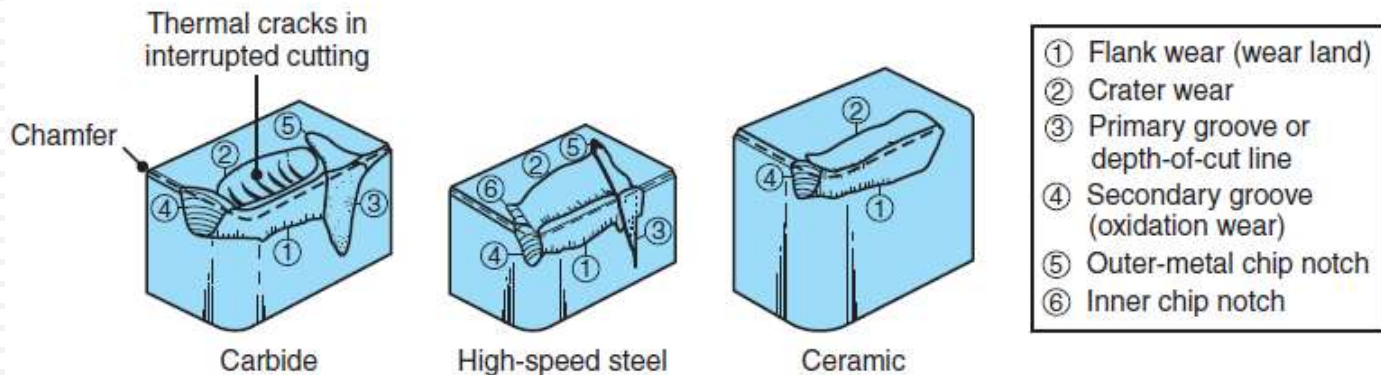

(a) Types of wear associated with various cutting tools

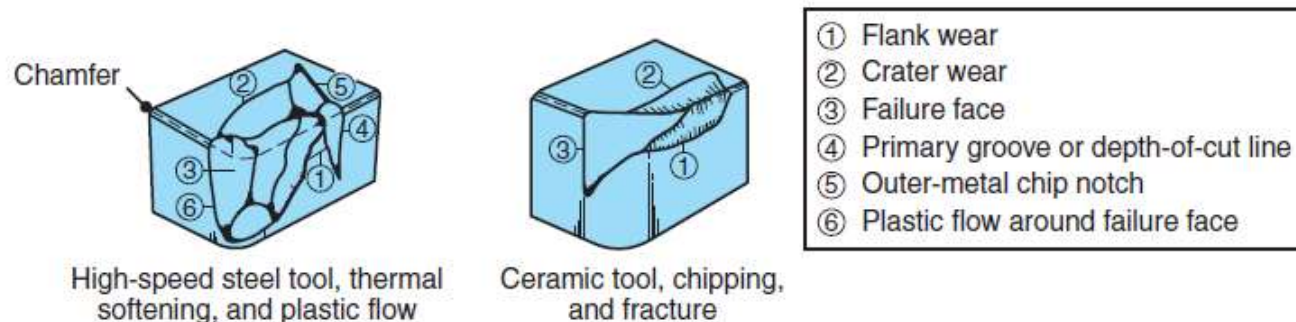

(b) Catastrophic tool failures (many variables involved)

# Tool Life: Wear and Failure:

## Crater Wear

59

- Factors influencing crater wear are:
  1. Temperature at the tool-chip interface.
  2. Chemical affinity between tool and workpiece materials.
  
- Crater wear occurs due to “**diffusion mechanism**”
  - This is the movement of atoms across tool-chip interface.
  - Since diffusion rate increases with increasing temperature, ⇒ crater wear increases as temperature increases (as indicated in the figure below).
  - Note how quickly crater wear-rate increases in a small temperature range
  - Coatings to tools is an effective way to slow down diffusion process (e.g. titanium nitride, aluminum oxide).

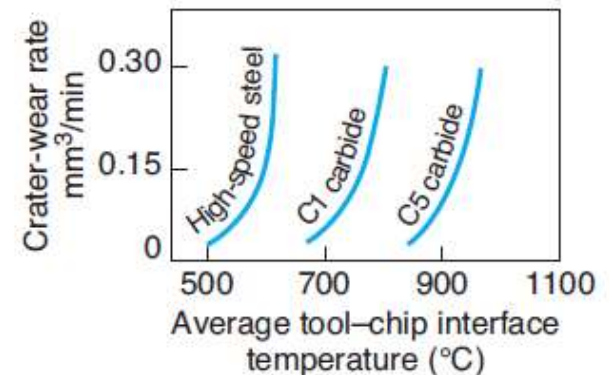

# Tool Life: Wear and Failure:

## Crater Wear

60

- Location of the max depth of crater wear,  $KT$  ([slide 48](#)), coincides with the location of the *max temperature* at the tool-chip interface (see the figure on the right)
  - Note, how the crater-wear pattern coincides with the discoloration pattern.
  - Discoloration is an indication of high temperatures.

Interface of a cutting tool (right) and chip (left) in machining plain carbon-steel.

Compare this with [slide 42](#).

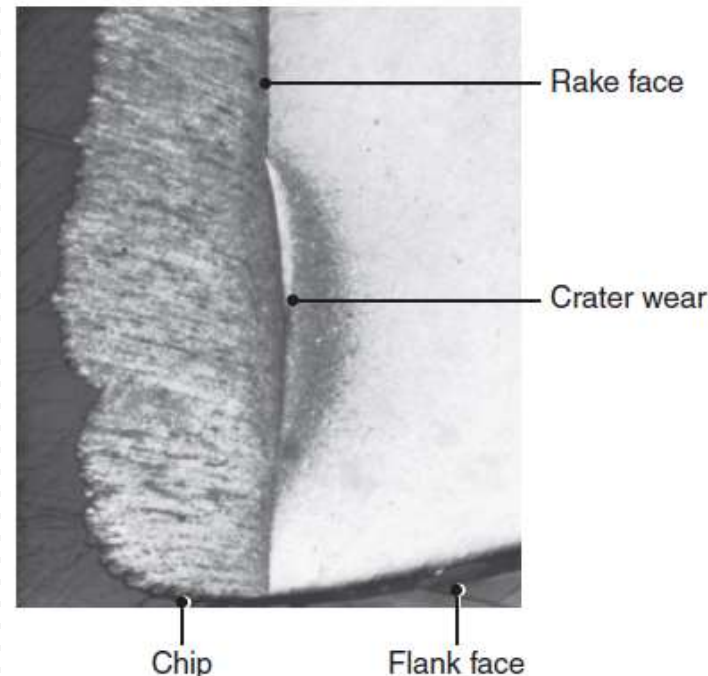

# Tool Life: Wear and Failure:

## Other Types of Wear, Chipping, and Fracture

61

- **Nose wear** ([slide 48](#)) is the rounding of a sharp tool due to mechanical and thermal effects.
  - ▣ It dulls the tool, affects chip formation, and causes rubbing of the tool over the workpiece.
  - ▣ This raises the tool temperature, and causes residual stresses on the machined surface.
  
- Tools also may undergo **plastic deformation** because of temperature rises in the cutting zone.
  - ▣ Temp. may reach 1000 °C (or higher in stronger materials).
  
- **Notches** or **grooves** ([slides 48, 58](#)) occur at boundary where chip no longer touches tool.
  - ▣ Boundary is called **depth- of-cut (DOC) line**.
  - ▣ Can lead to gross chipping in the tool (due to small area).

# Tool Life: Wear and Failure:

## Other Types of Wear, Chipping, and Fracture

62

- Tools may undergo **chipping**, where small fragment from the cutting edge of the tool breaks away.
  - Mostly occurs with brittle tool materials (e.g. ceramics).
  - Small fragments: “microchipping” or “macrochipping”.
  - Large fragments: “gross fracture” or “catastrophic failure”.
  
- Chipping may occur in a region of the tool where a small crack already exists.
  - This causes sudden loss of tool material, change in tool shape.
  - ⇒ drastic effects on surface finish, dimensional accuracy.
  
- Two main causes of chipping
  - **Mechanical shock** (impact due to interrupted cutting).
  - **Thermal fatigue** (variations in temperature due to interrupted cutting).
  - Note, thermal cracks are  $\perp$  to rake face ([slide 58](#))

# Tool Life: Wear and Failure:

## Tool-condition Monitoring

63

- It is very important to continuously monitor the condition of the cutting tool to observe wear, chipping, gross failure.
  
- Tool-condition monitoring systems are integrated into computer numerical control (CNC) and programmable logic controllers (PLC).
  
- Classified into 2 categories:
  1. **Direct methods**
  
  2. **Indirect methods**

# Tool Life: Wear and Failure:

## Tool-condition Monitoring

64

1. **Direct methods** for observing the condition of a cutting tool involves optical measurements of wear.
  - e.g. periodic observation of changes in the tool using microscope.
  - e.g. programming tool to touch a sensor after every machining cycle (to detect broken tools).
2. **Indirect methods** of observing tool conditions involve the correlation of the tool condition with certain parameters.
  - Parameters include forces, power, temperature rise, workpiece surface finish, vibration, chatter.
  - e.g. transducers which correlate acoustic emissions (from stress waves in cutting) to tool wear and chipping.
  - e.g. transducers which continually monitor torque and forces during cutting, plus measure and compensate for tool wear.
  - e.g. sensors which measure temperature during machining.

# Surface Finish and Integrity

65

- **Surface finish:**
  - Influences not only the dimensional accuracy of machined parts but also their properties and performance in service.
  - Describes the geometric features of a *surface*.
  
- **Surface integrity**
  - Refers to *material properties*, such as fatigue life and corrosion resistance, that are strongly affected by the *nature* of the surface produced.
  
- The following discussion pertains to showing the different factors that affect surface finish and surface integrity.

# Surface Finish and Integrity

66

- The *built-up edge* (BUE) has the greatest influence on surface finish (due to large effect on tool-tip surface).
  - Damage shown in the figures below is due to BUE.
  - It appears as “scuffing” (i.e. scratching) marks.
  - In normal machining: marks would appear as straight grooves.
  - Note: diamond, ceramic tools have best surface finish (no BUE).

Machined surfaces produced on steel (highly magnified)  
a) turned surface  
b) surface produced by shaping



(a)



(b)

# Surface Finish and Integrity

67

- A *dull* tool has a large  $R$  along its edges (like dull pencil).
  - ▣ although the tool in orthogonal cutting has +ve rake angle ( $\alpha$ ),
  - ▣ for small depths of cut:  $\alpha$  can become  $-ve$ .
  - ▣  $\Rightarrow$  the tool overrides the workpiece (i.e. no cutting) and burnishes the surface (i.e. rubs on it), and no chips are produced.
  - ▣  $\Rightarrow$  the workpiece temperature  $\uparrow$  and this causes residual stresses.
  - ▣  $\Rightarrow$  surface damage: tearing, cracking.
  - ▣ this occurs when the tip radius of the tool is large in relation to the depth of cut.
  - ▣ solution is to choose: depth of cut  $>$  tip radius.

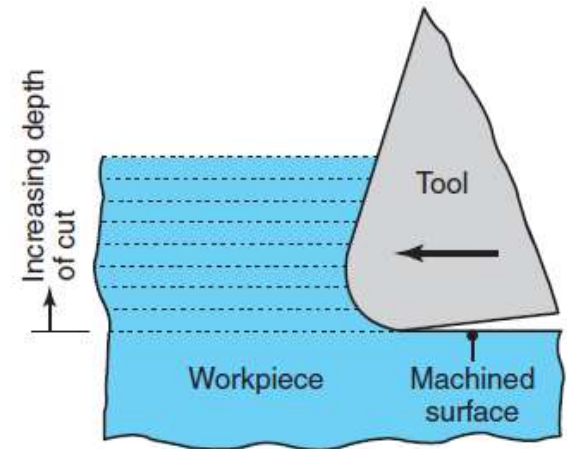

# Surface Finish and Integrity

68

- In a turning operation, the tool leaves a spiral profile (**feed marks**) on the machined surface as it moves across the workpiece (see the figure below):
  - ▣ as feed ( $f$ )  $\uparrow$  + tool nose ( $R$ )  $\downarrow \Rightarrow$  marks become more distinct.
  - ▣ the typical *surface roughness* is expressed as

$$R_t = \frac{f^2}{8R}$$

where,  $R_t$ , is the roughness height.

- ▣ Feed marks are important to consider in *finish machining* (not *rough machining*).

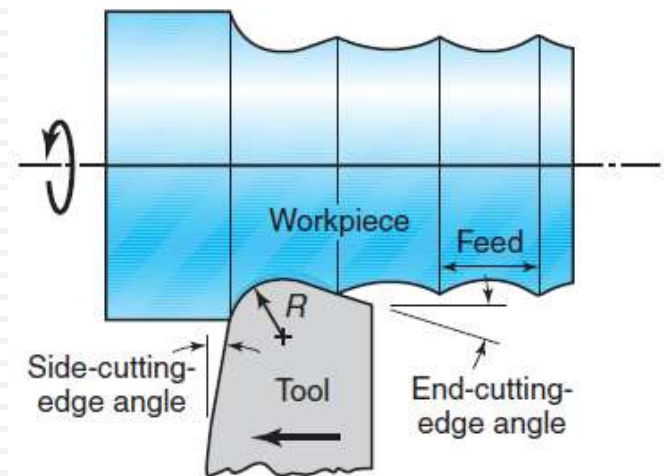

# Surface Finish and Integrity

69

- Vibration and chatter
  - adversely affects the workpiece surface finish.
  - tool vibration  $\Rightarrow$  variations in cutting dimensions.
  - chatter  $\Rightarrow$  chipping, premature failure in brittle tools (e.g. ceramics, diamond).
  
- Factors influencing the *surface integrity* (adversely) are:
  1. Temperatures generated during processing, and possible metallurgical deformations.
  2. Surface residual stresses.
  3. Severe plastic deformation and strain hardening of the machined surfaces, tearing and cracking.
  - Note, each of these factors can be controlled by carefully choosing and maintaining cutting tools.

# Surface Finish and Integrity

70

## Rough machining vs. Finish machining

- Rough machining
  - focus: removing a large amount of material at a high rate.
  - surface finish is not emphasized since it will be improved during finish machining.
  
- Finish machining
  - focus is on the surface finish to be produced.
  - Note, it is important that the workpiece has developed no subsurface-damage due to rough machining (as in [slide 66](#)).



# Machinability

71

- *The machinability of a material* is defined in terms of:
  1. Surface finish and surface integrity of the machined part,
  2. Tool life,
  3. Force and power required,
  4. The level of difficulty in chip control.
  
- Good machinability indicates
  - ▣ good surface finish and surface integrity,
  - ▣ a long tool life, and
  - ▣ low force and power requirements.
  
- Note, continuous chips should be avoided ([slide 18](#)) for good machinability.

# Machinability

72

## Machinability ratings (indexes)

- these have been used to determine machinability.
- available for each type of material and its condition.
- not used much anymore due to their qualitative nature.
- e.g.: AISI 1112 steel with a rating of 100:
  - for a tool life of 60 min,
  - choose 30 m/min cutting speed (for machining this material).
- these are mostly qualitative aspects ⇒ not sufficient to guide operator to machining parts economically.
- Other guides for various materials should include: cutting speed, feed, depth of cut, cutting tools and shape, cutting fluids.

# Machinability

73

- Machinability is discussed for the following:
  - Ferrous Metals (e.g. steels, stainless steels, cast iron, etc.).
  - Nonferrous Metals (e.g. aluminum, copper, magnesium).
  - Miscellaneous Materials (e.g. thermoplastics, ceramics).
  - Thermally assisted machining.

## Machinability of Ferrous Metals: Steels

- **Carbon steels** have a wide range of machinability.
  - If a carbon steel is too ductile, chip formation can produce built-up edge, leading to poor surface finish.
  - If too hard, it can cause abrasive wear of the tool because of the presence of carbides in the steel.
  - Cold-worked carbon steels: preferred machinability.

# Machinability:

## Machinability of Ferrous Metals

74

### Steels (cont)

- **Free-machining steels:** contain *sulfur + phosphorus*

**Sulfur** forms manganese sulfide inclusions, which

- Act as stress raisers in the primary shear zone.
- ⇒ chips are small, break easily (i.e. machinability ↑).
- Important to choose size, shape, distribution of inclusions.

**Phosphorus** has two major – desirable – effects:

1. Strengthens ferrite ⇒ better chip formation, surface finish ↑.
  2. Increases hardness ⇒ short (non-continuous chips).
- Note, soft steels have low machinability since they have tendency to form BUE ⇒ poor surface finish.

# Machinability:

## Machinability of Ferrous Metals

75

### Steels (cont)

- **Leaded steels** (e.g. 10L45 steel)
  - Lead acts as a *solid* lubricant (due to low shear strength) at tool-chip interface during cutting.
  - It also acts as a *liquid* lubricant in front of tool when the temperature is high.
  - In addition, It ↓ shear stress at the primary shear zone ⇒ ↓ forces and ↓ power consumption.
  - Lead is, however, dangerous environmental toxin ⇒ there is a trend to eliminate the use of lead in steel: “**lead-free steels**”.
  - Good substitutes: **bismuth**, and **tin** (but performance is lower).

# Machinability:

## Machinability of Ferrous Metals

76

### Steels (cont)

#### □ Calcium-deoxidized steels

- they contain oxide flakes of calcium silicates ( $\text{CaSiO}_3$ ) that
  - reduce the strength of the secondary shear zone, and
  - decrease tool-chip interface friction and wear.
  - $\Rightarrow$  temperature increases are reduced  $\Rightarrow$  less crater wear.

#### □ Alloy steels

- They have a large variety of compositions and hardnesses
- $\Rightarrow$  machinability cannot be generalized,
- but they have higher hardness and other properties.
- Can be used to produce good surface finish, integrity, dimensional accuracy.

# Machinability:

## Machinability of Ferrous Metals

77

### Effects of Various Elements in Steels

- Presence of *aluminum* and *silicon* is harmful in steels
  - Reason: combine with oxygen to form aluminum oxide and silicates, which are hard and abrasive.
  - ⇒ tool wear increases and machinability is reduced.
  
- Note that as machinability↑, other properties may ↓
  - e.g. lead causes *embrittlement* of steel at high temperature (although has no effect at room temperature).
  - e.g. sulfur can reduce hot workability of steel.

# Machinability:

## Machinability of Ferrous Metals

78

### **Stainless Steels**

- *Austenitic* (300 series) steels are difficult to machine (needs machine tool with high stiffness to avoid chatter).
- *Ferritic* stainless steels (also 300 series) have good machinability.
- *Martensitic* (400 series) steels are abrasive, tend to form BUE.
- *Precipitation-hardening* stainless steels: strong and abrasive, ⇒ require hard, abrasion-resistant tool.

### **Cast Irons**

- *Gray irons*: machinable, but abrasive (especially, *pearlite*).
- *Nodular, malleable* irons: machinable with hard materials.

# Machinability:

## Machinability of Nonferrous Metals

79

### □ Aluminum

- very easy to machine.
- but softer grades: form BUE  $\Rightarrow$  poor surface finish.
- $\Rightarrow$  recommend high cutting speeds, high rake and relief angles.

### □ Beryllium

- requires machining in a controlled environment.
- this is due to toxicity of fine particles produced in machining.

### □ Cobalt-based alloys

- abrasive and work hardening.
- require sharp, abrasion-resistant tool materials, and low feeds and speeds.

### □ Copper

- can be difficult to machine because of BUE formation.

# Machinability:

## Machinability of Nonferrous Metals

80

### □ Magnesium

- very easy to machine, good surface finish, prolonged tool life.
- Caution: high rate of oxidation and fire danger.

### □ Titanium and its alloys

- have very poor thermal conductivity.
- ⇒ high temperature rise and BUE ⇒ difficult to machine.

### □ Tungsten

- brittle, strong, and very abrasive.
- ⇒ machinability is low.

### □ Zirconium

- Good machinability.
- Requires cooling cutting fluid (danger of explosion, fire).

# Machinability:

## Machinability of Miscellaneous Materials

81

### □ **Thermoplastics**

- Machining requires sharp tools with positive rake angles, large relief angles, small depths of cut and feed, and high speeds.
- Cooling also required to keep chips from sticking to tools.

### □ **Polymer-matrix composites:**

- Very abrasive  $\Rightarrow$  difficult to machine.
- Also, requires careful handling; avoid touching, inhaling fibers.

### □ **Metal-matrix and ceramic-matrix composites**

- can be difficult to machine depending on the properties of the matrix material and the reinforcing fibers.

### □ **Graphite**

- Abrasive.
- Requires sharp, hard, abrasion-resistant tools.

# Machinability:

## Machinability of Miscellaneous Materials

82

### □ **Ceramics**

- Have steadily improving machinability (e.g. *nanoceramics*).
- Require appropriate processing parameters.

### □ **Wood**

- Properties vary with grain direction.
- ⇒ type of chips and surfaces vary significantly depending on the type of wood and its condition.
- Basic requirements: sharp tools, high cutting speeds.

# Machinability:

## Thermally Assisted Machining

83

- Metals and alloys that are hard to machine at room temperature can be machined at higher temperature.
- *Thermally assisted machining (hot machining)*
  - a source of heat is focused onto an area just ahead of the cutting tool (e.g. steels hot machined at 650°-750°).
  - e.g. of heat source: torch, electric current, laser-beam.
  - Generally difficult and complicated to perform in plants.
- Advantages of hot machining are:
  1. Reduced cutting forces.
  2. Increased tool life.
  3. Higher material-removal rates.
  4. Reduced tendency for vibration and chatter.