

IE-352
Summer Semester 1432-33 H
MANUFACTURING PROCESSES - 2

Homework 1

Name:

Student Number:

Read the following gages:

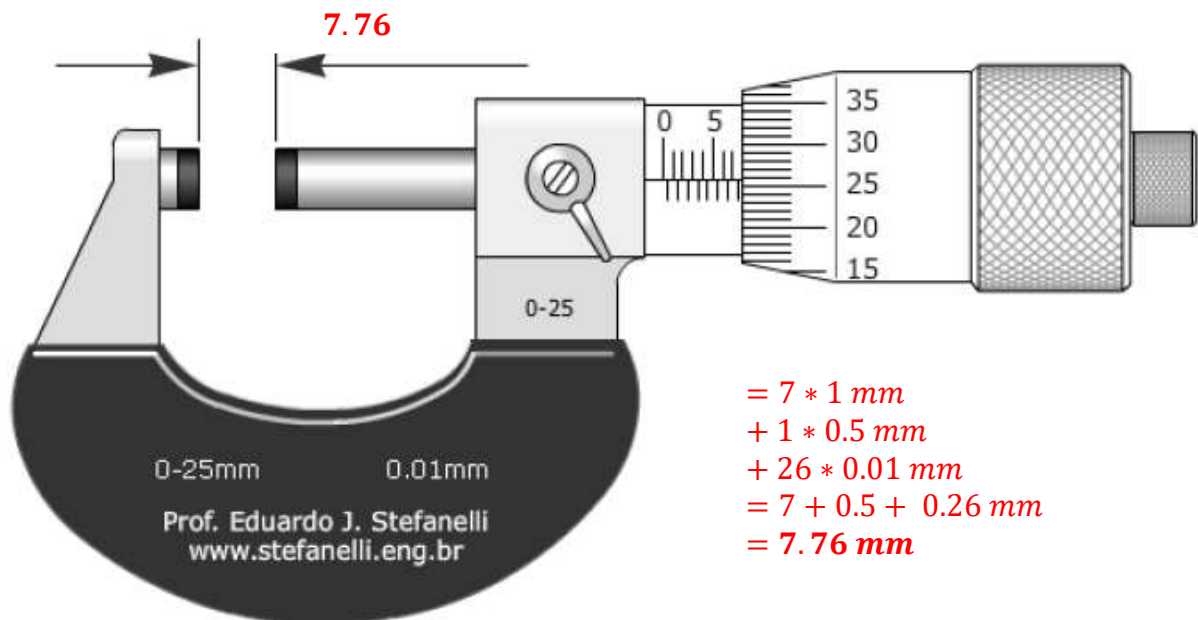

1.

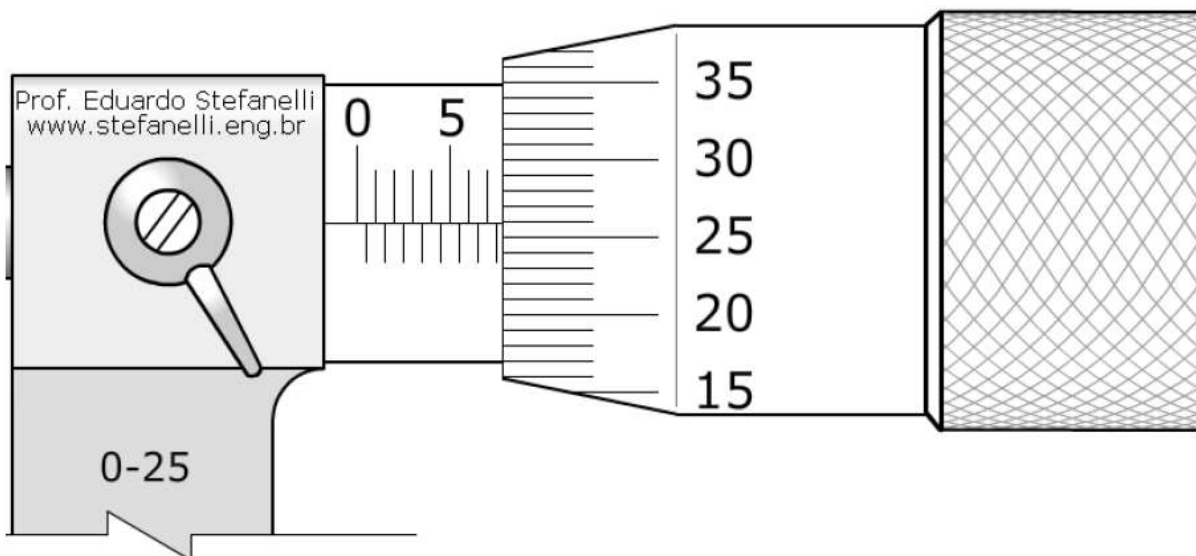

Q1. ANSWER: **7.76 mm**

2.

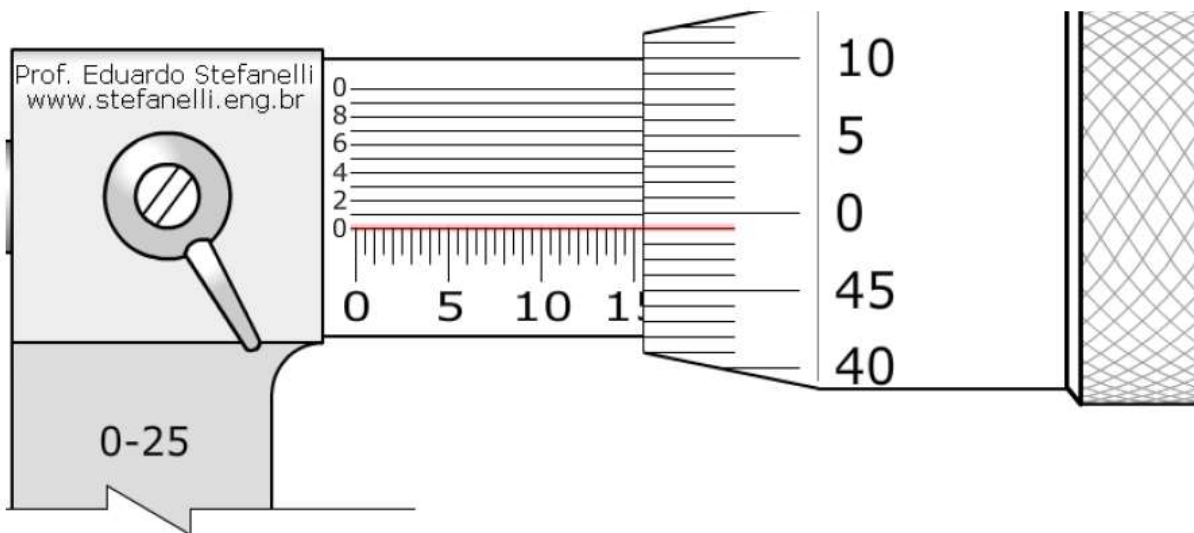
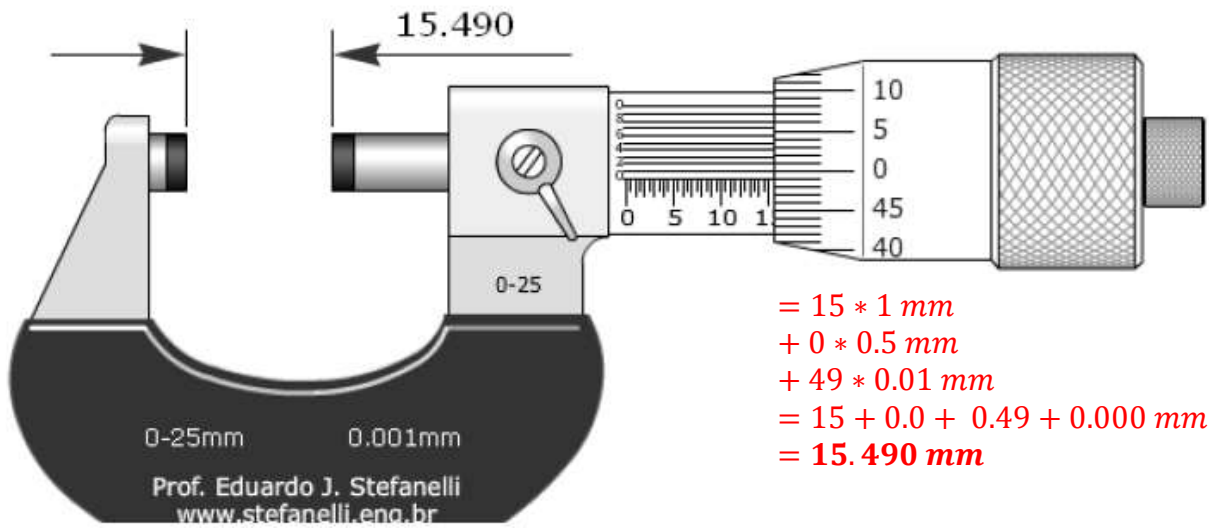

Q2. ANSWER: 15.490 mm

0.0197

$= 0 * 0.1 \text{ in}$
 $+ 0 * 0.025 \text{ in}$
 $+ 19 * 0.001 \text{ in}$
 $+ 7 * 0.0001 \text{ in}$
 $= 0.019 + 0.0007 \text{ in}$
 $= \mathbf{0.0197 \text{ in}}$

3. Prof. Eduardo J. Stefanelli
www.stefanelli.eng.br

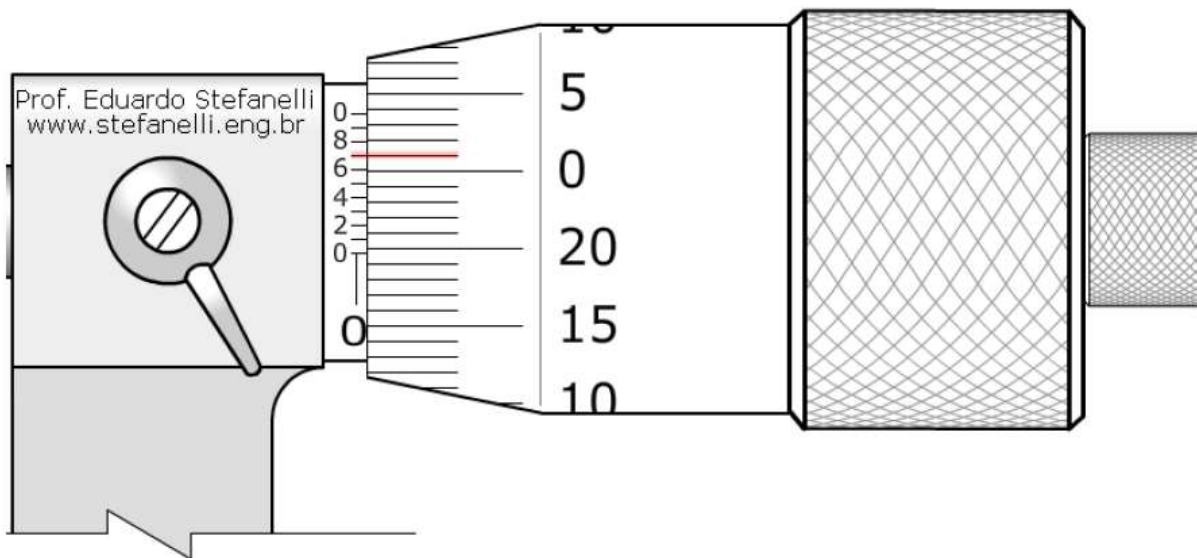

Q3. ANSWER: **0.0197 in**

$= 1 * 10 \text{ mm}$
 $+ 7 * 0.1 \text{ mm}$
 $= \mathbf{10.7 \text{ mm}}$

4. ?

Q4. ANSWER: **10.7 mm**

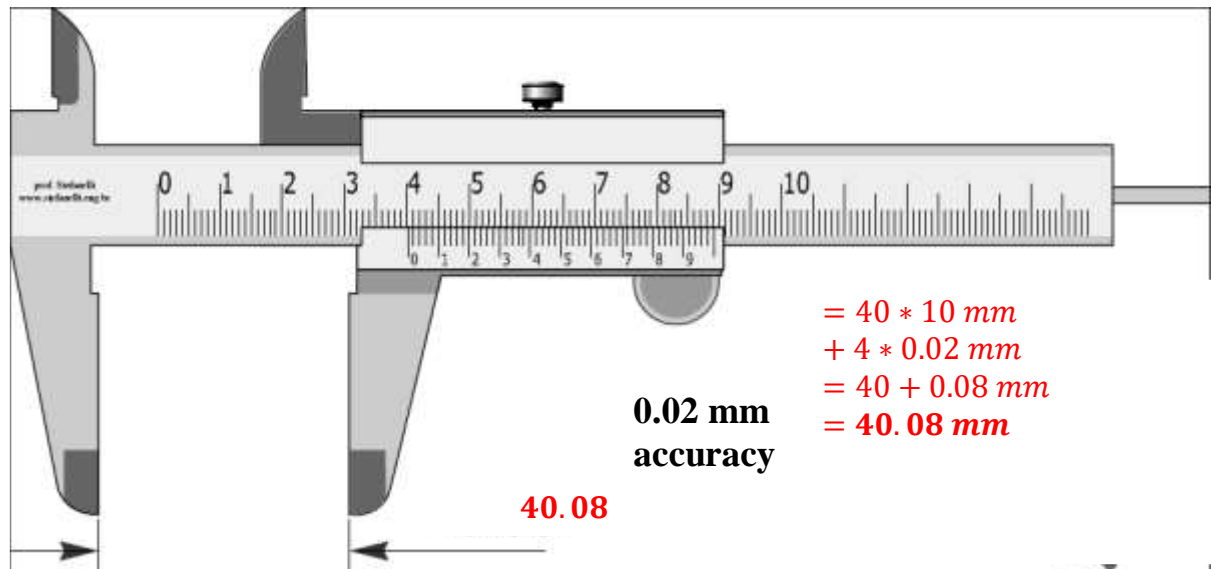

5.

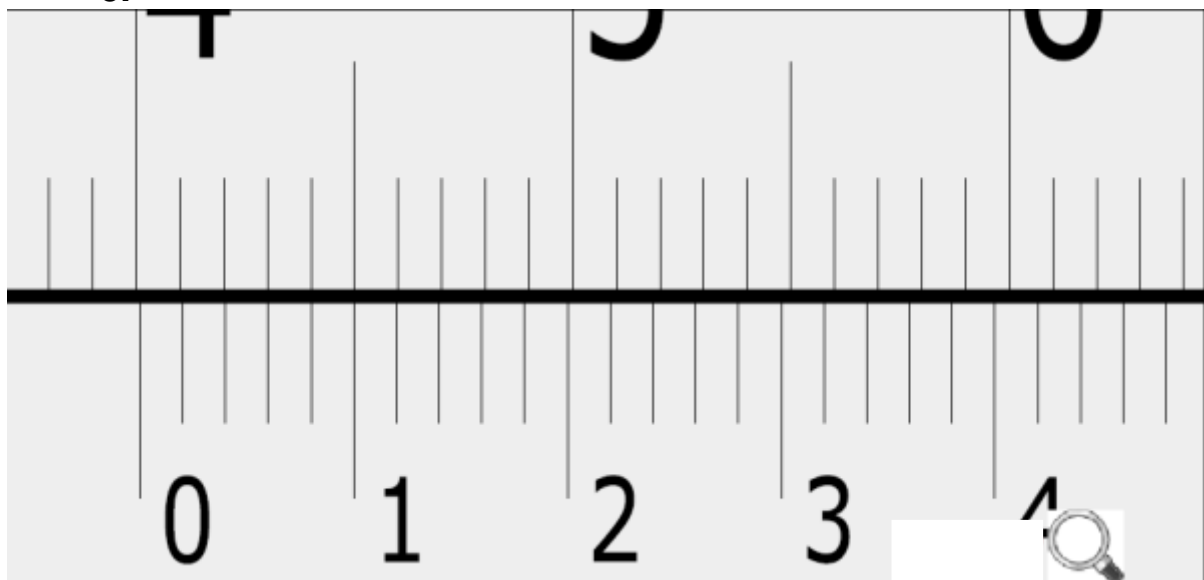

Q5. ANSWER:

40.08 mm

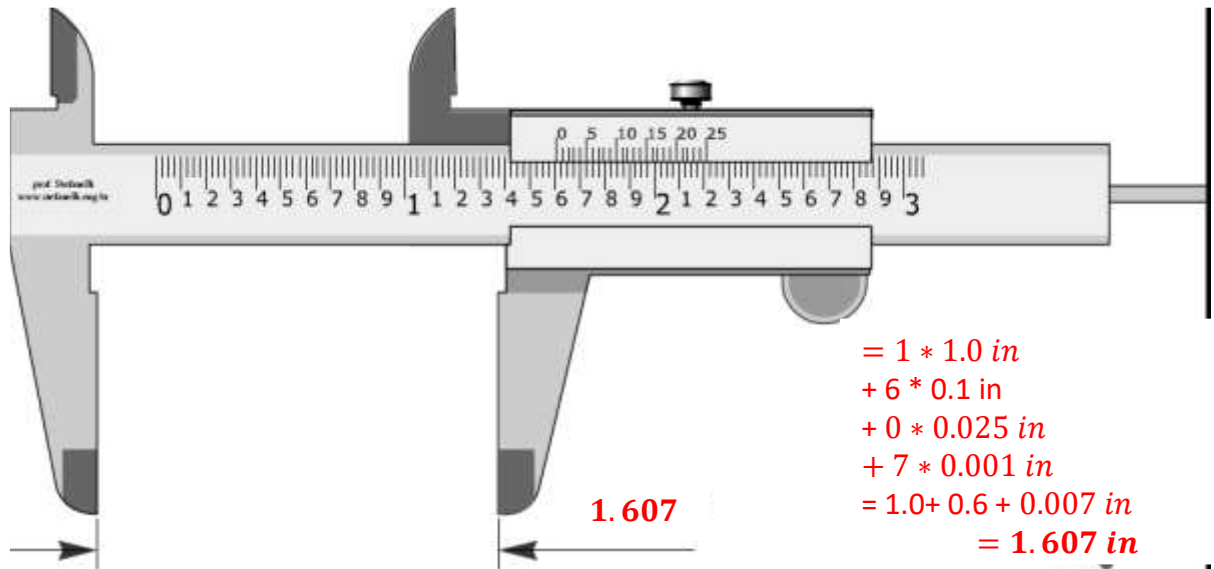

6.

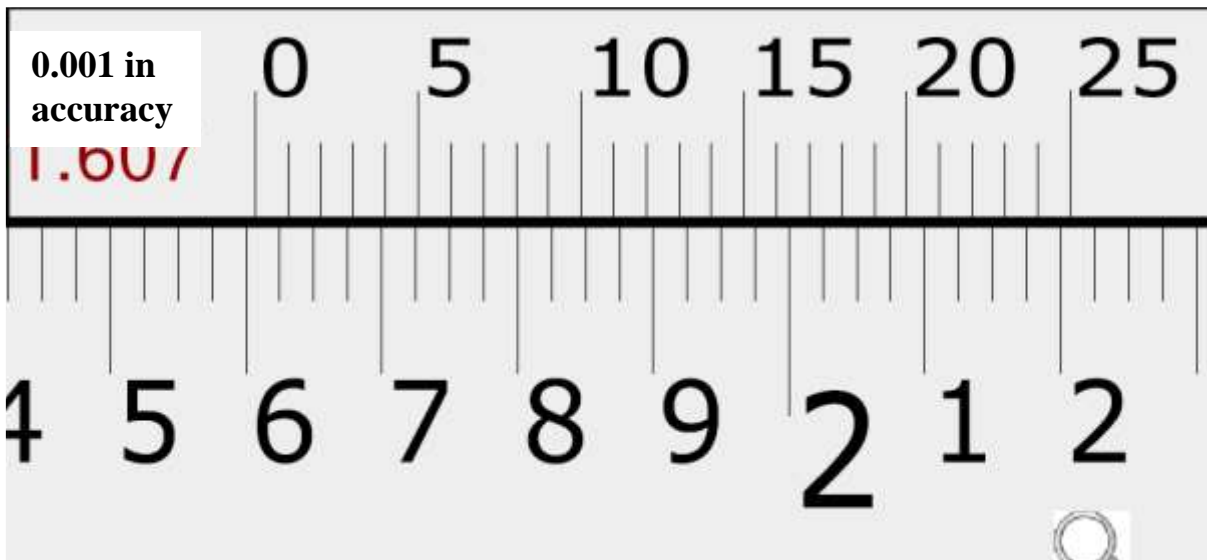

Q6. ANSWER: **1.607 in**