

# NETWORK PERFORMANCE

---

**CEN 449**

**BROADBAND AND HIGH SPEED  
NETWORKS**

**Dr. Ashraf Abdelaziz Taha**

# NETWORK PERFORMANCE

---

- ❑ determined by parameters like: bandwidth and latency.
  - **Bandwidth:** the number of bits can be transferred in a unit of time. Broadband means the number is large.
  - **Latency:** the time it takes to transfer a certain size of message from one end to the other end. High-speed means the latency should be short.

# CIRCUIT-SWITCHING AND PACKET-SWITCHING

## Circuit Switching

- ❑ Long-haul telecom network designed for voice
- ❑ Network resources dedicated to one call
- ❑ Obstacles when used for data:
  - + Inefficient (high idle time)
  - + Constant data rate

## Packet Switching

- ❑ Data transmitted in short blocks, or packets
- ❑ Packet length < 1000 octets
- ❑ Each packet contains user data plus control info (routing)
- ❑ Store and forward

# SWITCHING

---

A switch is a mechanism that allows us to interconnect links to form a larger network. A switch is a multi-input, multi-output device, which transfers packets from an input to one or more outputs.

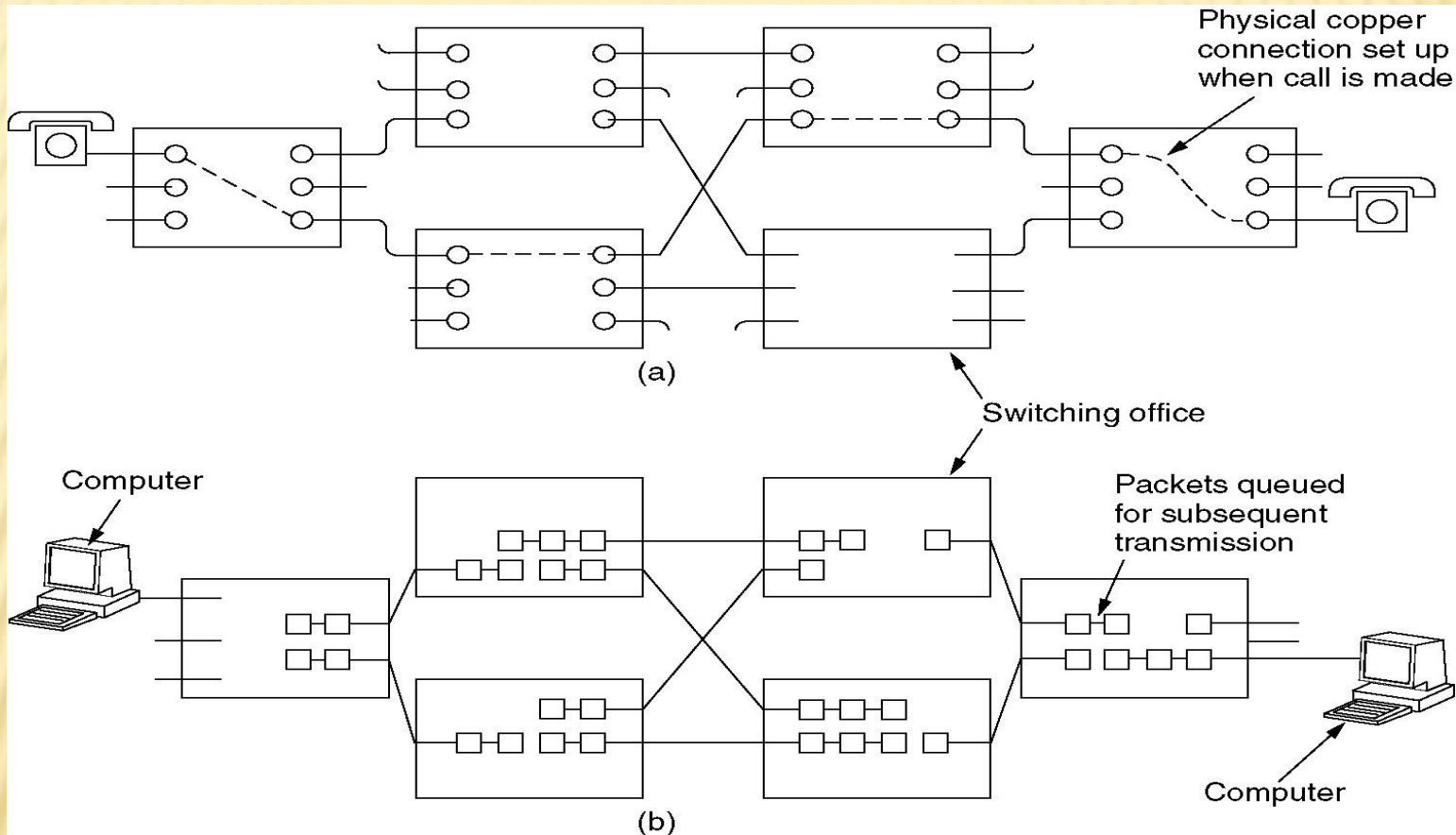

**(a) Circuit switching**

**(b) Packet switching**

# PACKET-SWITCHING NETWORKS

- ❑ Basic technology the same as in the 1970s
- ❑ One of the few effective technologies for long distance data communications
- ❑ Frame relay and ATM are variants of packet-switching

## **Advantages:**

- + flexibility, resource sharing, robust, responsive

## **Disadvantages:**

- + Time delays in distributed network, overhead penalties
- + Need for routing and congestion control

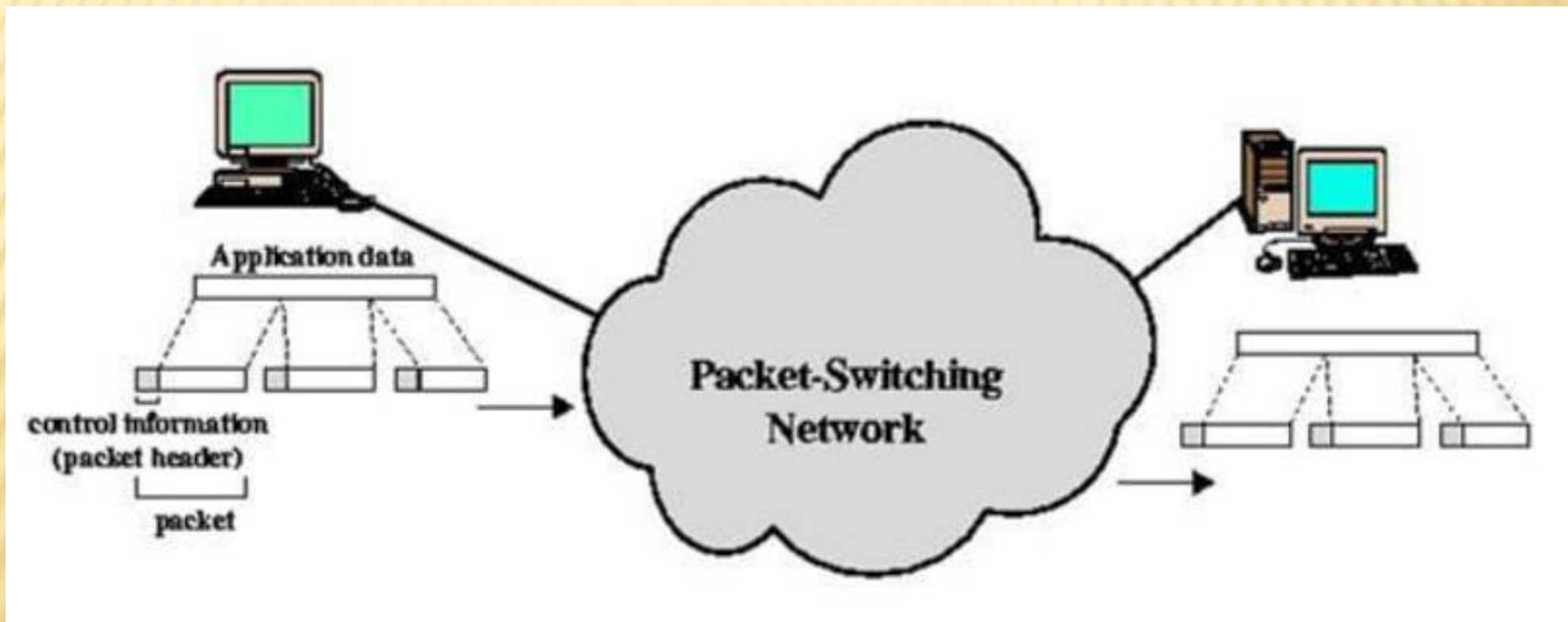

## The Use of Packets

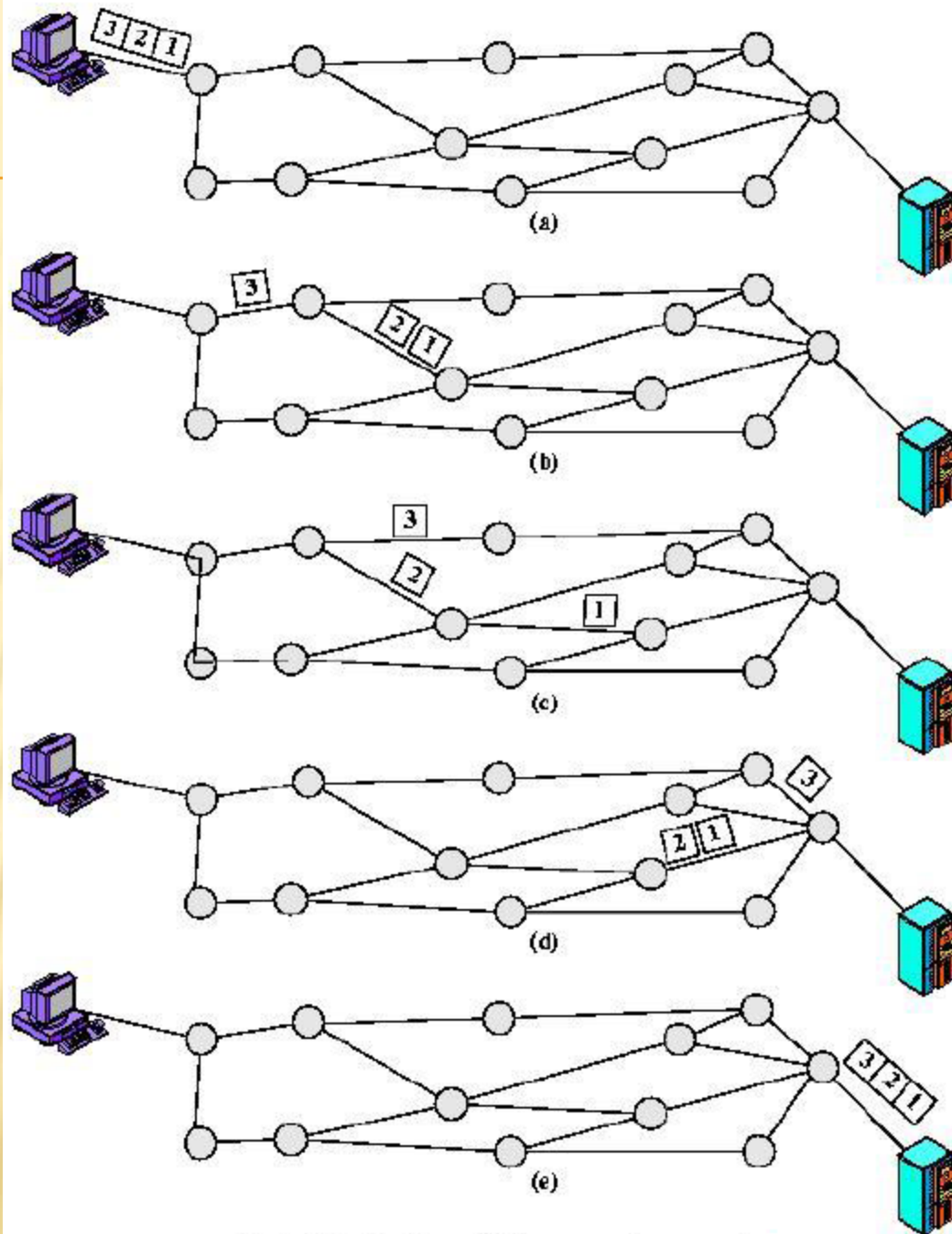

Packet Switching: Datagram Approach

# ADVANTAGES OVER CIRCUIT-SWITCHING

---

- ❑ Greater line efficiency (many packets can go over shared link)
- ❑ Data rate conversions
- ❑ Non-blocking under heavy traffic (but increased delays)

# DISADVANTAGES RELATIVE TO CIRCUIT-SWITCHING

- ✘ Packets incur additional delay with every node they pass through
  - + Jitter: variation in packet delay
- ✘ Data overhead in every packet for routing information, etc
- ✘ Processing overhead for every packet at every node traversed

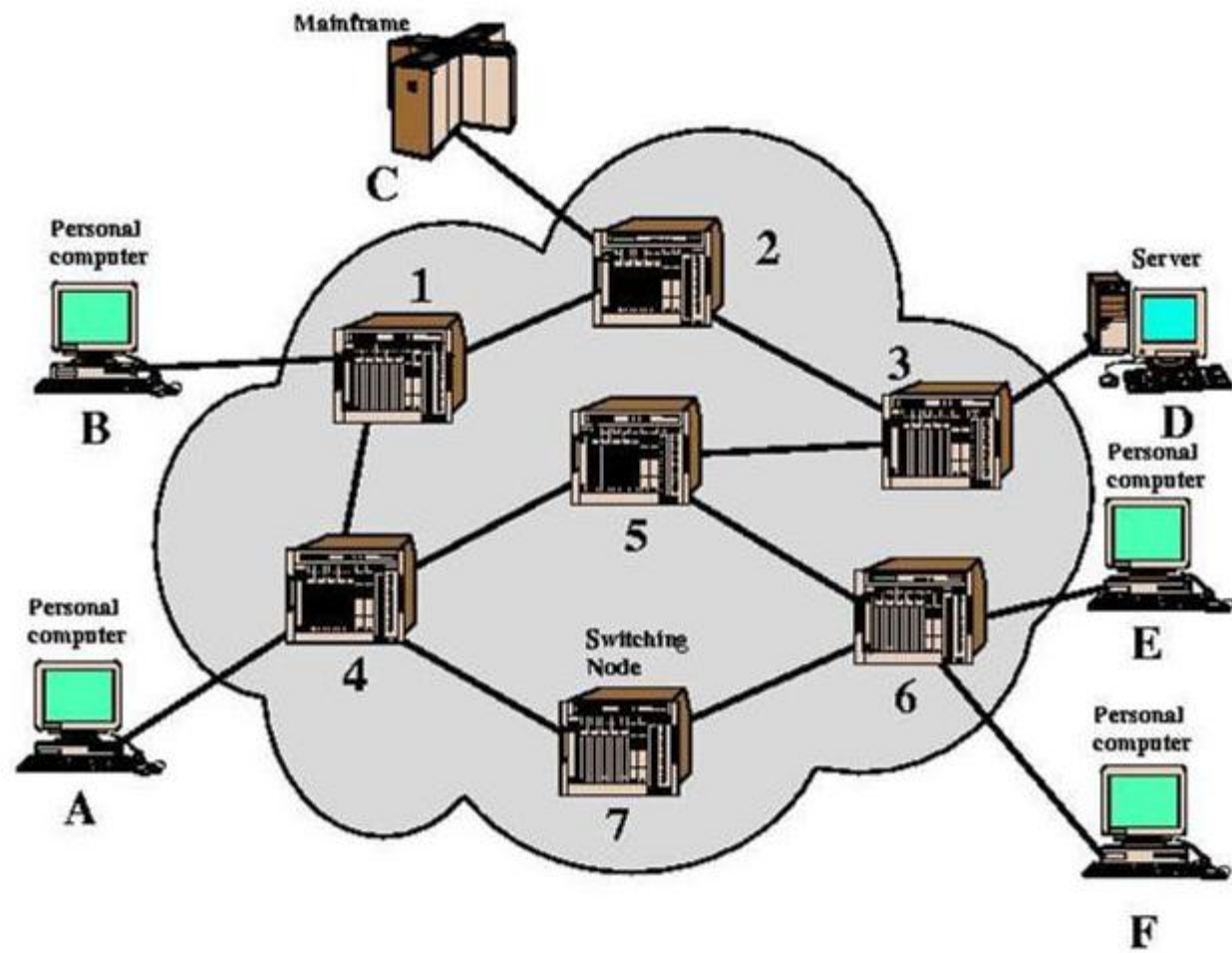

Simple Switching Network

# SWITCHING TECHNIQUE

---

- ✘ Large messages broken up into smaller packets
- ✘ Datagram
  - + Each packet sent independently of the others
  - + No call setup
  - + More reliable (can route around failed nodes or congestion)
- ✘ Virtual circuit
  - + Fixed route established before any packets sent
  - + No need for routing decision for each packet at each node

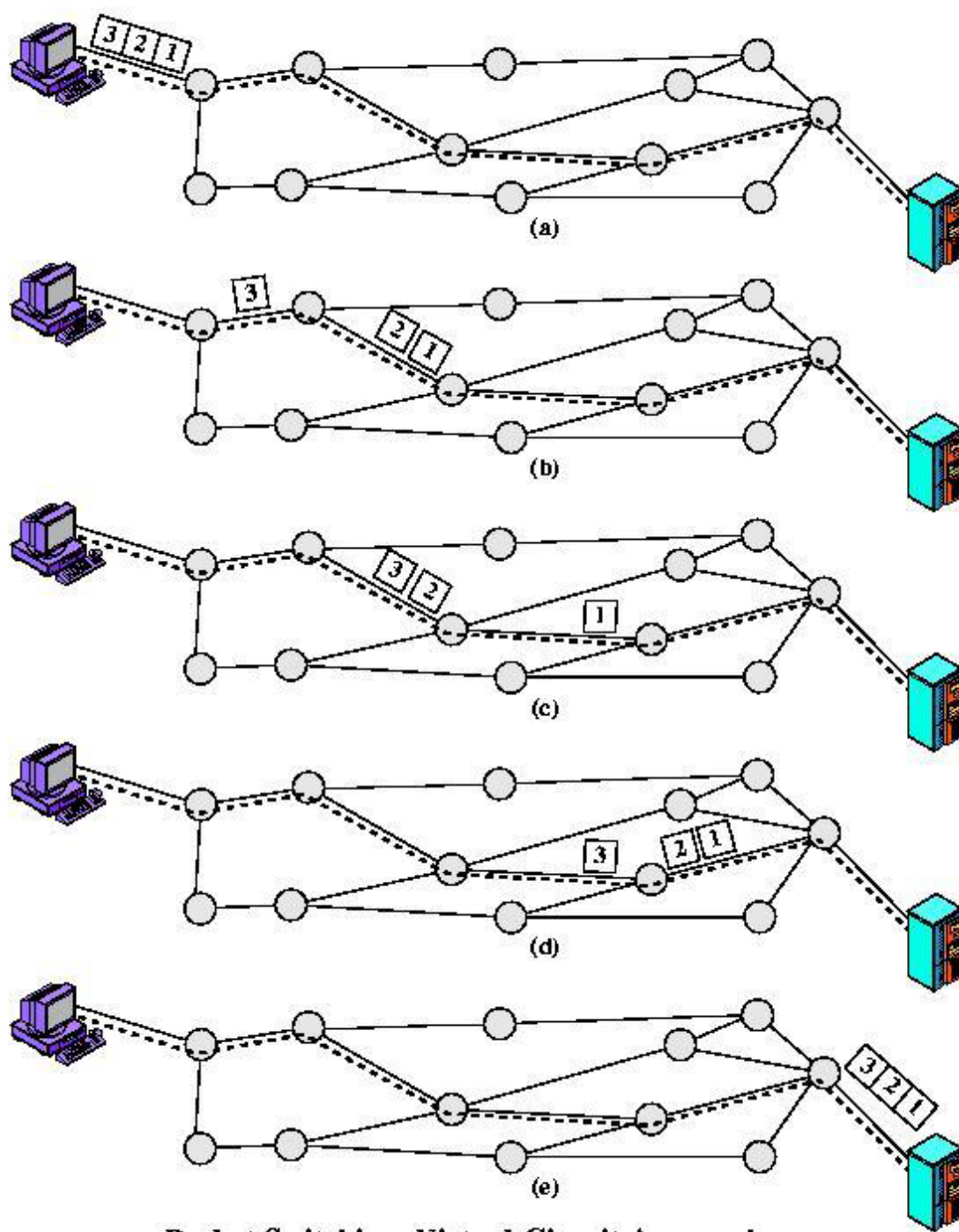

**Packet Switching: Virtual-Circuit Approach**