

# Chapter 6

## Digital Control Systems

# Introduction

- In almost all applications, both the plant and the actuator are analog systems.
- In digital control systems, analog compensators (analog circuits) are replaced with a digital computer (or micro-Controller, microprocessor).

A/D converter converts analog signals to digital signals.

D/A converter converts digital signals to analog signals.

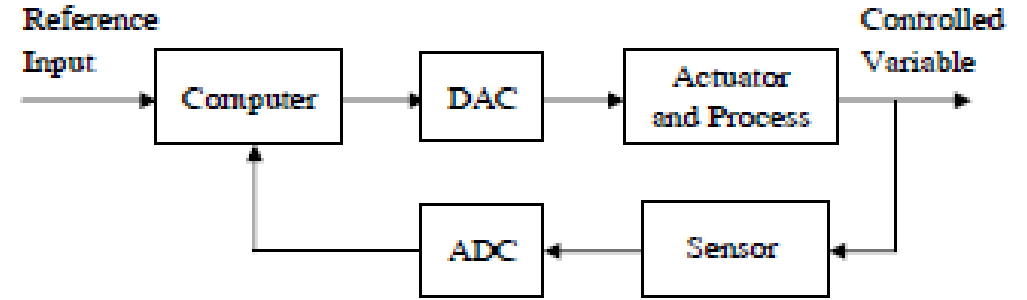

Figure: Configuration of a digital control system.

## • Digital control offers distinct advantages over analog control

1. **Accuracy:** Digital signal represented by 12 bits or more represents high precision and small error compared to analog signal.
2. **Reduced cost:** A single digital computer can replace numerous analog controllers with a subsequent reduction in cost.
3. **Flexibility in response to design changes:** Modifications can be implemented with software changes rather than expensive hardware modifications.
4. **Noise immunity:** Digital systems exhibit more noise immunity than analog systems.

## Difference equations (discrete-time model describing a system)

$$y(k + n) = a_{n-1}y(k + n - 1) + \dots + a_1y(k + 1) + a_0y(k) = b_nu(k + n) + \dots + b_0u(k)$$

Difference equation of order  $n$ . If the forcing function  $u(k)$  is equal to zero, the equation is said to be homogeneous.

If the equation is linear and the coefficients  $a_i, b_i$  are constant, the difference equation is linear time invariant LTI.

# Signal Conversion

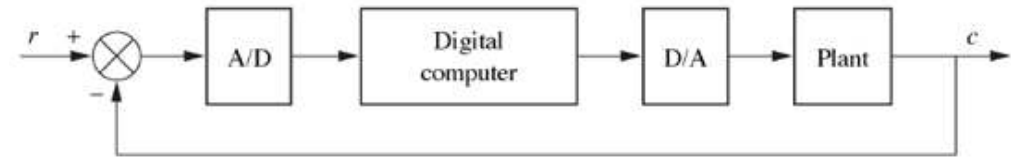

Fig.1. Placement of the digital computer within the loop; with A/D and D/A converters

## Analog-to-Digital Conversion (ADC model)

- The analog signal is sampled and held at periodic intervals by a *zero-order-holder* (Z-O-H) (staircase approximation to the analog signal.). The sampling rate must be at least twice the bandwidth of the signal (Nyquist sampling rate).
- The ADC converts the sample to a digital number (quantization and coding). **Quantization error** is due to the quantization process that rounds off the analog voltage to the next higher or lower level.

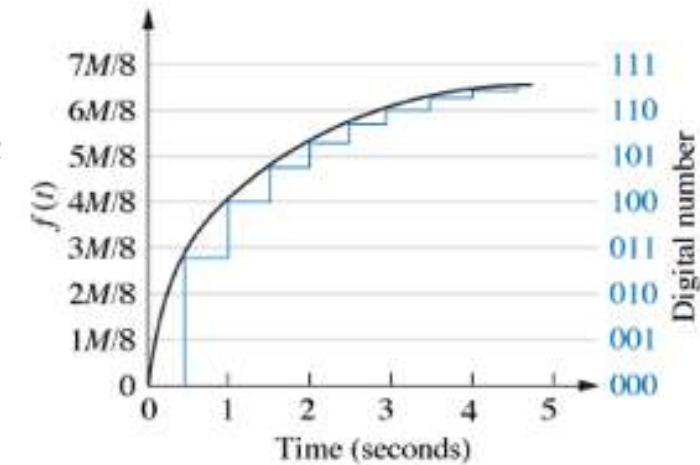
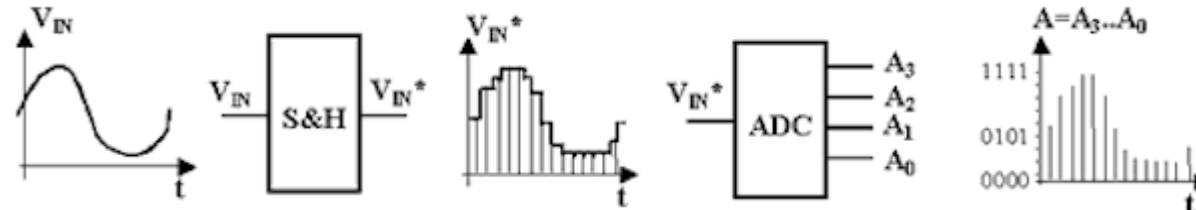

Fig.2. Analog-to-digital conversion

## Digital-to-Analog Conversion (DAC model)

- Properly weighted voltages are summed together to yield the analog output.
- the switches are electronic and are set by the input binary code.

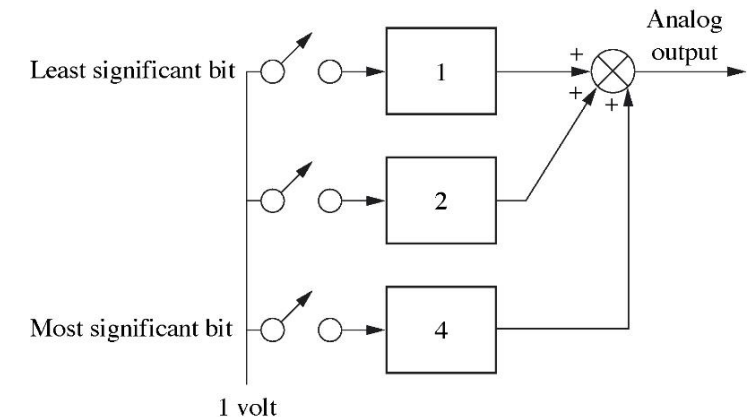
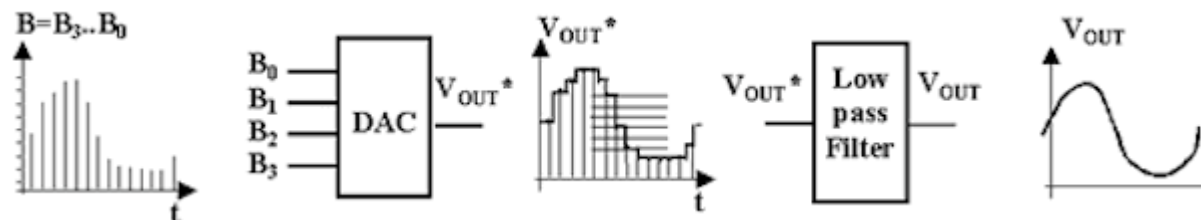

Fig.3. Digital-to-analog converter

# Z-Transform

- The z-transform is an important tool in the analysis and design of discrete-time systems. it plays a role similar to that served by Laplace transforms in continuous-time.

- Z-transform of a digital signal  $f(k)$  is:

$$F(z) = \sum_{k=-\infty}^{+\infty} f(k) \cdot z^{-k}$$

To overcome the nonlinearity problem, S-domain is transformed to another domain where the operator is linear: Z- domain by setting  $z = e^{sT}$ .

## Examples :

### UNIT IMPULSE

$$u(k) = \delta(k) = \begin{cases} 1, & k=0 \\ 0, & k \neq 0 \end{cases}$$

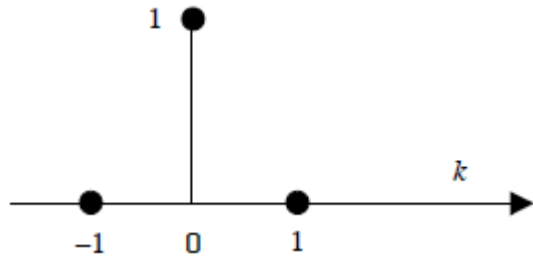

$$U(z) = 1$$

### SAMPLED STEP

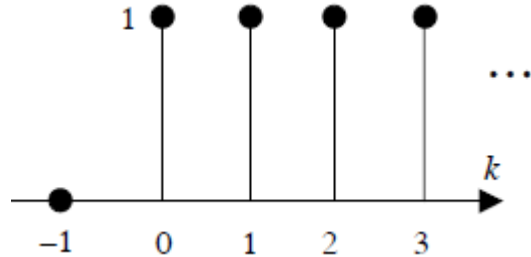

$$U(z) = 1 + z^{-1} + z^{-2} + z^{-3} + \dots + z^{-k} + \dots$$

$$= \sum_{k=0}^{\infty} z^{-k}$$

$$U(z) = \frac{1}{1 - z^{-1}}$$

$$= \frac{z}{z - 1}$$

### EXPONENTIAL

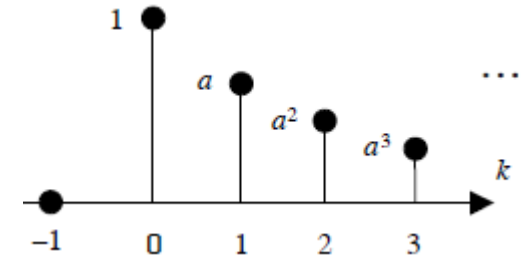

$$u(k) = \begin{cases} a^k, & k \geq 0 \\ 0, & k < 0 \end{cases}$$

$$U(z) = 1 + az^{-1} + a^2z^{-2} + \dots + a^kz^{-k} + \dots$$

$$U(z) = \frac{1}{1 - (a/z)}$$

$$= \frac{z}{z - a}$$

### 3.1 Partial table of z- and s-transforms

TABLE 13.1 Partial table of z- and s-transforms

	$f(t)$	$F(s)$	$F(z)$	$f(kT)$
1.	$u(t)$	$\frac{1}{s}$	$\frac{z}{z-1}$	$u(kT)$
2.	$t$	$\frac{1}{s^2}$	$\frac{Tz}{(z-1)^2}$	$kT$
3.	$t^n$	$\frac{n!}{s^{n+1}}$	$\lim_{a \rightarrow 0} (-1)^n \frac{d^n}{da^n} \left[ \frac{z}{z - e^{-aT}} \right]$	$(kT)^n$
4.	$e^{-at}$	$\frac{1}{s+a}$	$\frac{z}{z - e^{-aT}}$	$e^{-akT}$
5.	$t^n e^{-at}$	$\frac{n!}{(s+a)^{n+1}}$	$(-1)^n \frac{d^n}{da^n} \left[ \frac{z}{z - e^{-aT}} \right]$	$(kT)^n e^{-akT}$
6.	$\sin \omega t$	$\frac{\omega}{s^2 + \omega^2}$	$\frac{z \sin \omega T}{z^2 - 2z \cos \omega T + 1}$	$\sin \omega kT$
7.	$\cos \omega t$	$\frac{s}{s^2 + \omega^2}$	$\frac{z(z - \cos \omega T)}{z^2 - 2z \cos \omega T + 1}$	$\cos \omega kT$
8.	$e^{-at} \sin \omega t$	$\frac{\omega}{(s+a)^2 + \omega^2}$	$\frac{ze^{-aT} \sin \omega T}{z^2 - 2ze^{-aT} \cos \omega T + e^{-2aT}}$	$e^{-akT} \sin \omega kT$
9.	$e^{-at} \cos \omega t$	$\frac{s+a}{(s+a)^2 + \omega^2}$	$\frac{z^2 - ze^{-aT} \cos \omega T}{z^2 - 2ze^{-aT} \cos \omega T + e^{-2aT}}$	$e^{-akT} \cos \omega kT$

## 3.2 Some Properties

---

	<b>Theorem</b>	<b>Name</b>
1.	$z\{af(t)\} = aF(z)$	Linearity theorem
2.	$z\{f_1(t) + f_2(t)\} = F_1(z) + F_2(z)$	Linearity theorem
3.	$z\{e^{-aT}f(t)\} = F(e^{aT}z)$	Complex differentiation
4.	$z\{f(t - nT)\} = z^{-n}F(z)$	Real translation
5.	$z\{tf(t)\} = -Tz \frac{dF(z)}{dz}$	Complex differentiation
6.	$f(0) = \lim_{z \rightarrow \infty} F(z)$	Initial value theorem
7.	$f(\infty) = \lim_{z \rightarrow 1} (1 - z^{-1})F(z)$	Final value theorem

---

# The Inverse Z-Transform (IZT)

- Three methods for finding the inverse z-transform (the sampled time function from its z-transform) will be described:
  1. partial-fraction expansion.
  2. Residue.
  3. the power series method.
- Since the z-transform came from the sampled waveform, the inverse z-transform will yield only the values of the time function at the sampling instants.

## IZT via Partial-Fraction Expansion

- The Laplace transform consists of a partial fraction that yields a sum of terms leading to exponentials, that is,  $A/(s + a)$ .
- Knowing that:  $\frac{z}{z-a} \rightarrow a^{kT}$  or  $\frac{z}{z-e^{-bT}} \rightarrow \frac{1}{s+b} \rightarrow e^{-b k T}$

$$F(z) = \frac{N(z)}{D(z)} \Rightarrow \frac{F(z)}{z} = \frac{A}{z-a} + \frac{B}{z-b} + \dots \Rightarrow F(z) = \frac{A z}{z-a} + \frac{B z}{z-b} + \dots$$

- The inverse is:  $f(kT) = A a^k + B b^k + \dots$

# Example

Given the function  $F(z)$  find the sampled time function.

$$F(z) = \frac{0.5 z}{(z - 0.5)(z - 0.7)}$$

## SOLUTION

---

- First we divide  $F(z)$  by  $z$  ( $z$ -functions have often the term  $z$  in their numerator), then we perform a partial-fraction expansion

$$\frac{F(z)}{z} = \frac{0.5}{(z - 0.5)(z - 0.7)} = \frac{A}{z - 0.5} + \frac{B}{z - 0.7} = \frac{-2.5}{z - 0.5} + \frac{2.5}{z - 0.7}$$

- Next, multiply through by  $z$ . 
$$F(z) = \frac{0.5 z}{(z - 0.5)(z - 0.7)} = \frac{-2.5 z}{z - 0.5} + \frac{2.5 z}{z - 0.7}$$

- Thus the inverse  $z$ -transform  $f(k) = -2.5(0.5)^k + 2.5(0.7)^k$

- The ideal sampled time function is: 
$$f^*(t) = \sum_{k=0}^{\infty} f(kT) \cdot \delta(t - Kt) = \sum_{k=0}^{\infty} (-2.5(0.5)^k + 2.5(0.7)^k) \cdot \delta(t - Kt)$$

# Time Response and Transfer Function of a discrete system

- The *response* of an LTI discrete-time system to an input sequence is given by the *convolution* of the input sequence and the impulse response sequence of the system (transfer function of the system  $h(k)$ ).

System's transfer function

$$y(k) = h(k) * u(k) = \sum_{i=0}^{\infty} h(k-i)u(i)$$

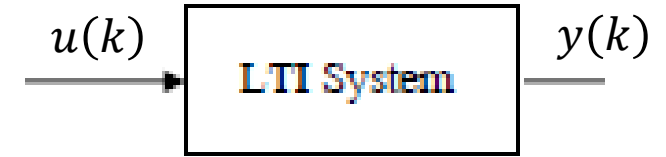

- The *z-transform of the convolution* of two time sequences is equal to the *product of their z-transforms*.

$$Y(z) = \sum_{k=0}^{\infty} y(k)z^{-k} = \sum_{k=0}^{\infty} \left[ \sum_{i=0}^{\infty} h(k-i)u(i) \right] z^{-k} \xrightarrow{j=k-i} Y(z) = \sum_{i=0}^{\infty} \sum_{j=-i}^{\infty} u(i)h(j) z^{-(i+j)} = \left[ \sum_{i=0}^{\infty} u(i)z^{-i} \right] \left[ \sum_{j=0}^{\infty} h(j)z^{-j} \right]$$

Causality property

$$\boxed{Y(z) = H(z) U(z)}$$

$H(z)$  is the transfer function of the system

**Example:** Given the discrete-time system  $y(k+1) - y(k) = u(k+1)$ , find the system transfer function and the system response to a sampled unit step.

The transfer function:  $zY(z) - Y(z) = zU(z) \implies H(z) = \frac{Y(z)}{U(z)} = \frac{z}{z-1}$

unit step response:  $Y(z) = H(z)U(z) = \frac{z}{z-1} \frac{z}{z-1} = z \frac{z}{(z-1)^2} = zR(z) \xrightarrow{\text{Inverse Z-transform}} y(k) = \begin{cases} k+1 & k \geq 0 \\ 0 & k < 0 \end{cases}$  Time advanced ramp

unit step's z-transform      z-transform of unit ramp

# Modeling the Digital Computer

## Modeling the Sampler

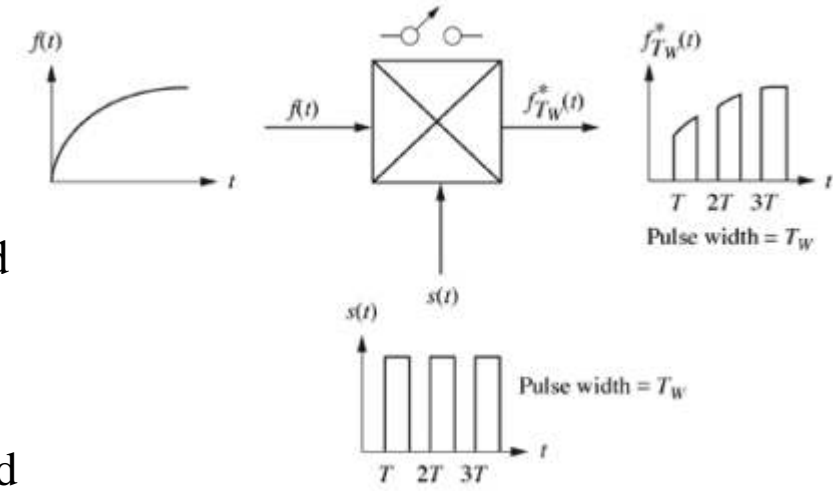

FIG.1. uniform-rate sampling (switch opening and closing), product of time waveform and sampling waveform

- The objective is to derive a mathematical model for the digital computer (transfer function) as represented by a sampler and zero-order hold.
- When signals are sampled, the Laplace transform can be replaced by another related transform called *the z-transform*.
- The sampling model is a switch turning on and off at a uniform sampling rate  $T$ . It can also be considered to be a product of the time waveform to be sampled  $f(t)$  and a sampling function  $s(t)$  with pulse width  $T_w$ .
- The time equation of the sampled waveform  $f_{T_w}^*(t)$

$$f_{T_w}^*(t) = f(t) \cdot s(t) = f(t) \cdot \sum_{k=-\infty}^{+\infty} [u(t - kT) - u(t - kT - T_w)] = T_w \cdot f^*(t)$$

Hold
ideal sampler  
↓
↓

Using the Laplace transform,  
 Replace  $e^{-T_w s}$  with its series expansion  
 Laplace inverse transform

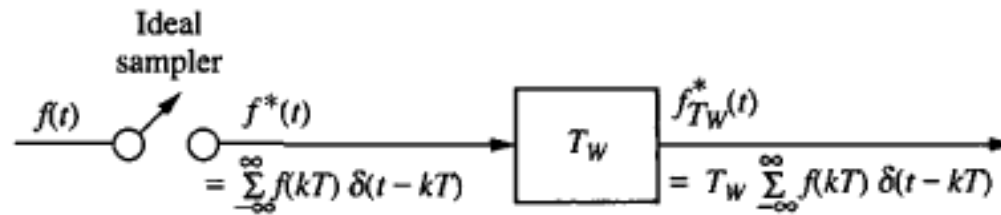
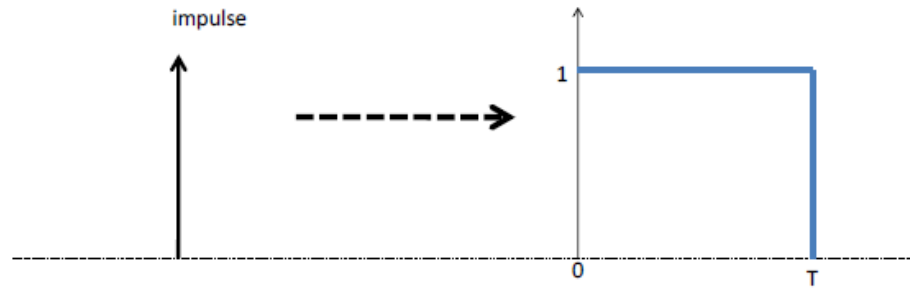

Fig.2. Model of sampling with a uniform rectangular pulse train

# Modeling the Digital Computer

## Modeling the zero-order hold

- The digital computer is modeled by cascading two elements: (1) an ideal sampler and (2) a zero-order hold.
- The zero-order hold follows the sampler and holds the last sampled value of  $f(t)$ .
- Using an impulse input at zero time, the output is a step that starts at  $t = 0$  and ends at  $t = T$



The output is:  $y(t)=h(t)=u(t)-u(t-T) \rightarrow$  Laplace transform is:

$$L\{u(t)-u(t-T)\} = \frac{1}{s} - \frac{1}{s} e^{-Ts} = \frac{1-e^{-Ts}}{s}$$

### Proof

$$L\{u(t)-u(t-T)\} = \int_0^{\infty} u(t)e^{-st} dt - \int_0^{\infty} u(t-T)e^{-st} dt = \int_0^{\infty} e^{-st} dt - \int_T^{\infty} e^{-st} dt = \left(-\frac{1}{s} e^{-st}\right) \Big|_0^{\infty} - \left(-\frac{1}{s} e^{-st}\right) \Big|_T^{\infty}$$

$$\Rightarrow L\{u(t)-u(t-T)\} = \frac{1}{s} - \frac{1}{s} e^{-Ts} = \frac{1 - e^{-Ts}}{s}$$

$u(t-T) = 1$  for  $t \geq T$



$$ZOH(s) = G_h(s) = \frac{1 - e^{-Ts}}{s}$$

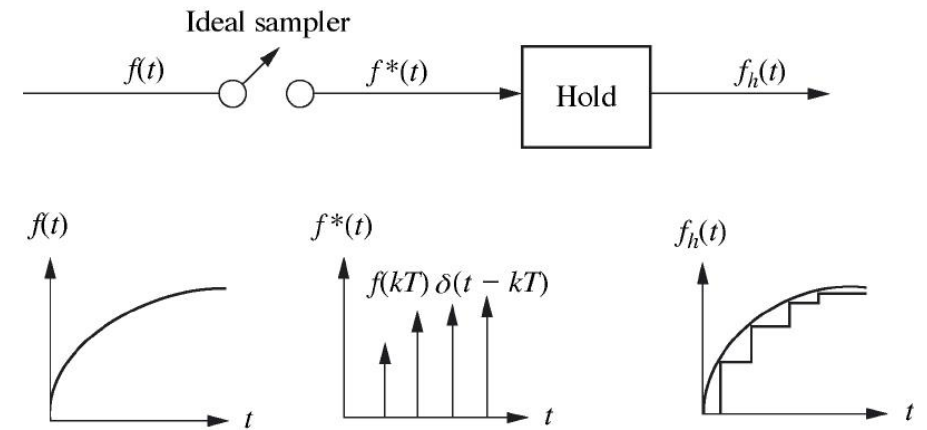

FIGURE (1) Ideal sampling and the zero-order hold

## Example: Converting $G_1(s)$ in Cascade with z.o.h. to $G(z)$

Given a z.o.h. in cascade with  $G_1(s) = \frac{s+2}{s+1}$  or  $G(s) = \frac{1-e^{-Ts}}{s} \frac{s+2}{s+1}$

find the sampled-data transfer function,  $G(z)$ , if the sampling time,  $T$ , is 0.5 second.

### SOLUTION

- Knowing that  $Z^{-1} = e^{-sT} \Rightarrow G(s) = (1 - e^{-Ts}) \frac{G_1(s)}{s} \Rightarrow G(z) = (1 - z^{-1}) \mathbb{Z} \left[ \frac{G_1(s)}{s} \right] = \frac{z-1}{z} \mathbb{Z} \left[ \frac{G_1(s)}{s} \right]$

- the impulse response (inverse Laplace transform) of  $\frac{G_1(s)}{s}$

$$G_2(s) = \frac{G_1(s)}{s} = \frac{s+2}{s(s+1)} = \frac{A}{s} + \frac{B}{s+1} = \frac{2}{s} - \frac{1}{s+1}$$

- Taking the inverse Laplace transform  $g_2(t) = 2 - e^{-t} \Rightarrow g_2(kT) = 2 - e^{-kT} \xrightarrow{\text{From Table}} G_2(z) = \frac{2z}{z-1} - \frac{z}{z-e^{-T}}$

- Substituting  $T = 0.5s$   $G_2(z) = \mathbb{Z} \left[ \frac{G_1(s)}{s} \right] = \frac{2z}{z-1} - \frac{z}{z-0.607} = \frac{z^2 - 0.213z}{(z-1)(z-0.607)}$



$$G(z) = \frac{z-1}{z} \mathbb{Z} \left[ \frac{G_1(s)}{s} \right] = \frac{z-0.213}{z-0.607}$$

# Available Commands for Continuous/Discrete Conversion

The commands `c2d`, `d2c`, and `d2d` perform continuous to discrete, discrete to continuous, and discrete to discrete (resampling) conversions, respectively.

```
sysd = c2d(sysc,Ts) % Discretization w/ sample period Ts
```

```
sysc = d2c(sysd) % Equivalent continuous-time model
```

```
sysd1= d2d(sysd,Ts) % Resampling at the period Ts
```

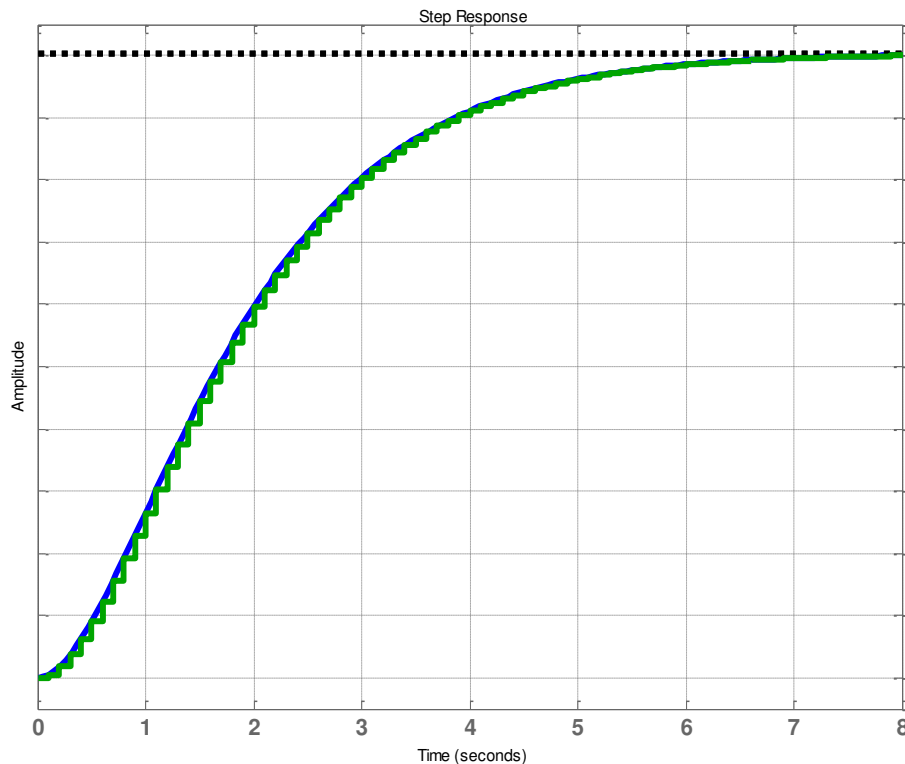

```
>> sys=tf(1,[1 2 1])
```

Transfer function:

$$1$$

-----  
 $s^2 + 2s + 1$

```
>> Ts=0.1; sysd=c2d(sys,Ts)
```

Transfer function:

$$0.004679z + 0.004377$$

-----  
 $z^2 - 1.81z + 0.8187$

Sampling time (seconds): 0.1

```
>> step(sys,sysd)
```

**MATLAB Code :**

**Continuous/Discrete system**

```
>> T=1;Num=1;Den=[1 0 0];
```

```
>> sysc=tf(Num,Den);
```

```
>> sysd=c2d(sysc,T,'zoh')
```

Transfer function:

$$0.5z + 0.5$$

-----  
 $z^2 - 2z + 1$

Sampling time (seconds): 1

# Block Diagram Reduction

- Objective:** find the closed-loop *sampled-data* transfer function of an arrangement of subsystems that have a *computer* in the loop. When manipulating block diagrams for sampled-data systems, the rule is:

$$Z\{G_1(s)G_2(s)\} \neq G_1(z)G_2(z) \quad \{G_1(s)G_2(s)\}^* \neq G_1(s)^* G_2(s)^* \quad \{G_1(s)G_2(s)^*\}^* = G_1(s)^* G_2(s)^*$$

Sampled data systems

Their z-transforms

$$C(z) = R(z)G(z)$$

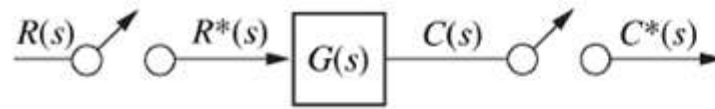

(a)

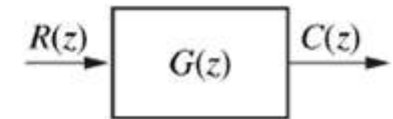

no sampler between  $G_1(s)$  and  $G_2(s)$

single transfer function  $G_1(s)G_2(s)=G_{12}(s)$

$$C(z) = R(z)G_{12}(z)$$



(b)

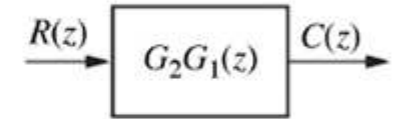

cascaded of two subsystems each like in (a)

$$C(z) = R(z) G_1(z) G_2(z)$$



(c)

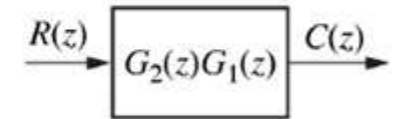

the continuous signal entering the sampler is  $R(s)G_1(s)$

$$RG_1(z)=Z\{R(s)G_1(s)\}$$

$$C(z) = RG_1(z) G_2(z)$$



(d)

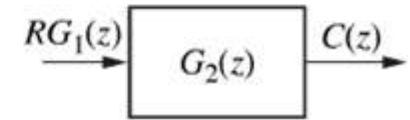
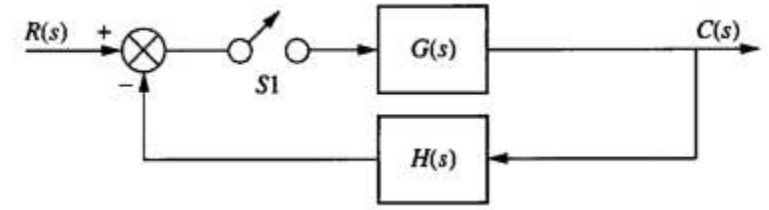

Figure Sampled-data systems and their z-transforms

# Example

Find the z-transform of the system shown in Figure



## SOLUTION

- The objective is to reduce the block diagram of Figure (a) and reducing it to the one shown in Figure (f).

- place a phantom sampler at the output of any subsystem that has a sampled input (is not an input to other subsystem)
- add phantom samplers S2 and S3 at the input to a summing junction whose output is sampled (synchronized samplers).

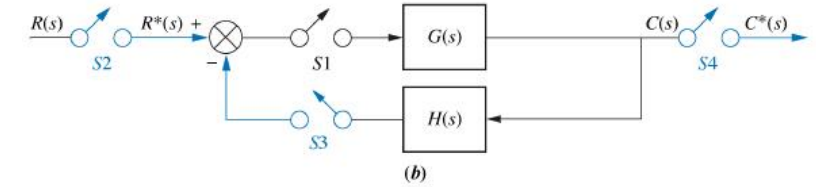
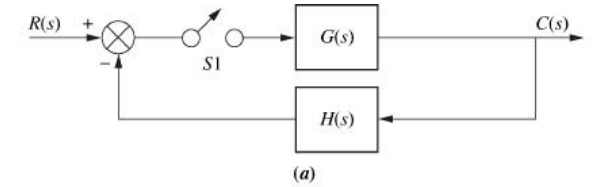

- move sampler S1 and G(s) to the right past the pickoff point (to yield a sampler at the input of G(s)H(s))

$G(s)H(s)$  with samplers S1 and S3 becomes  $GH(z)$

$G(s)$  with samplers S1 and S4 becomes  $G(z)$

Converting  $R^*(s)$  to  $R(z)$  and  $C^*(s)$  to  $C(z)$

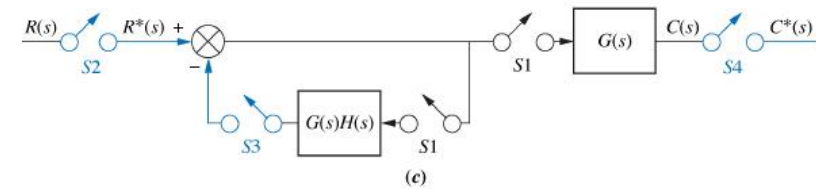

Now we have the system represented totally in the z-domain

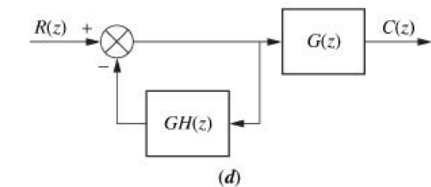

- using the feedback formula, we obtain the first block (Fig(e))

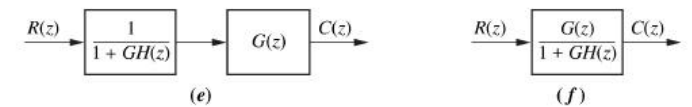

- multiplication of the cascaded sampled-data systems yields the final result (Fig(f))

Note: Phantom samplers are shown in color.

# 6 Stability

- The stability of digital system can be analyzed in Z-Domain or in S-Domain.
- Changes in *sampling rate* not only change the nature of the response from over-damped to underdamped, but also can turn a *stable system into an unstable one*.

## Digital System stability via Z-Plane

- In the S-plane, the region of stability is the left half-plane.
- If the transfer function,  $G(s)$ , is transformed into a sampled-data transfer function,  $G(z)$ , the region of stability on the z-plane can be evaluated from  $Z = e^{Ts}$ .
- Letting  $s = \alpha + j\omega$  we obtain:  $Z = e^{Ts} = e^{T(\alpha+j\omega)} = e^{\alpha T} e^{j\omega T} = e^{\alpha T} (\cos \omega T + j\sin \omega T) = e^{\alpha T} \angle \omega T$
- From the above equation, we can deduce that the stable domain that corresponds to  $\alpha < 0$ , lies inside the unity circle, the  $j\omega$  ( $\alpha=0$ ) axis lies on the unity circle, and the unstable domain  $\alpha > 0$  lies outside the unity circle.

- Thus, a digital system is stable if and only if all poles of the closed-loop transfer function  $T(z)$  are inside the unity circle.
- The digital system is marginally stable if poles of multiplicity one of the closed-loop transfer function  $T(z)$  are on the unity circle and other are inside the unity circle.

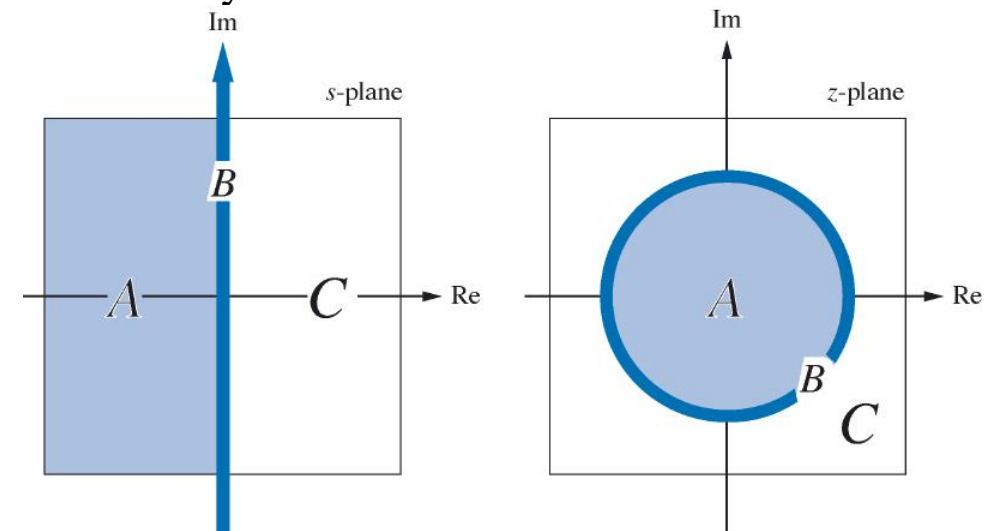

## Example

Study the stability of the closed-loop system in the figure.

Where  $G_1(s) = \frac{1}{s+2}$  and  $T=0.5s$

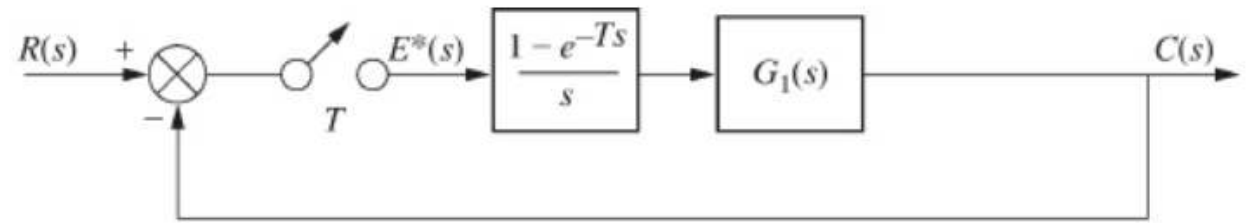

## SOLUTION

$$G(z) = (1 - z^{-1})\mathbb{Z}\left[\frac{G(s)}{s}\right] = \frac{0.316}{z - 0.368}$$

$$T(z) = \frac{G(z)}{1 + G(z)} = \frac{0.316}{z - 0.05}$$

since the pole is inside the unity circle then the system is stable.

## MATLAB Code:

```
>> T=1;Num=1;Den=[1 2];  
>> T=0.5;Num=1;Den=[1 2];  
>> sysc=tf(Num,Den);  
>> sysd=c2d(sysc,T,'zoh')
```

```
Transfer function:  
0.3161
```

```
-----  
z - 0.3679
```

```
Sampling time (seconds): 0.5
```

```
>> sysclD=feedback(sysd,1)
```

```
Transfer function:  
0.3161
```

```
-----  
z - 0.05182
```

```
Sampling time (seconds): 0.5
```

- We can check the stability with regards to the sampling period T:

$$G(s) = \frac{(1 - e^{-Ts})}{s(s + 2)} \Rightarrow G(z) = 0.5 \frac{1 - e^{-2T}}{z - e^{-2T}}$$

$$\Rightarrow T(z) = \frac{G(z)}{1 + G(z)} = \frac{0.5(1 - e^{-2T})}{z - (1.5e^{-2T} - 0.5)}$$

The pole is  $(1.5e^{-2T} - 0.5)$   
The system is stable for all  $T > 0$ .

- Let  $G(s) = \frac{10}{s+1} \Rightarrow G(z) = 10 \frac{(1 - e^{-T})}{z - e^{-T}} \Rightarrow T(z) = \frac{10(1 - e^{-T})}{z - (11e^{-T} - 10)}$

The pole is  $(11e^{-T} - 10)$   
The system is stable for:  
 $0 < T < 0.2$ .

for  $T = 0 \rightarrow 11e^{-0} - 10 = 1$       and      for  $T = 0.2 \rightarrow 11e^{-0.2} - 10 = -1$

- The pole is  $(11e^{-T} - 10)$ , monotonically decreases from +1 to -1 for  $0 < T < 0.2$ .
- For  $0.2 < T < \infty$ ,  $(11e^{-T} - 10)$  monotonically decreases from -1 to -10.
- Thus, the pole of  $T(z)$  will be inside the unit circle, and the system will be stable if  $0 < T < 0.2$ .
- In terms of frequency, where  $f = 1/T$ , the system will be stable as long as the sampling frequency is  $1/0.2 = 5$  hertz or greater.

# Stability via S-plane (Routh-Hurwitz criterion)

- Find the transformation from z-Domain to s-domain  $G(s) = G(Z)|_{z=e^{sT}}$  (nonlinear operator).
- The most used transformation is the *Bilinear Transformation*, where:  $Z = \frac{s+1}{s-1}$  (mapping from s-domain to z-domain)

**Example:** Let the characteristic equation of a system be:  $D(z) = z^3 - z^2 - 0.2z + 0.1 = 0$

In s-domain for  $Z = \frac{s+1}{s-1}$ , this is equivalent to :  $s^3 - 19s^2 - 45s - 17 = 0$ .

TABLE 13.3 Routh table for Example 13.8

$s^3$	1	-45
$s^2$	-19	-17
$s^1$	-45.89	0
$s^0$	-17	0

Thus system is unstable and has 1 pole outside the unity circle.  
No pole on the unity circle and two poles inside the unity circle.

# Steady-State Errors

## Effect of sampling upon the steady-state error

- Consider the digital system where the digital computer is represented by the sampler and zero-order hold. The transfer function of the plant is represented by  $G_I(s)$ .

- we have:  $E(z) = R(z) - C(z)$ ,

Or from (d):  $E(z) = \frac{R(z)}{1 + G(z)}$

$$\begin{aligned} E(z) &= R(z) - G(z)E(z) \\ E(z) + G(z)E(z) &= R(z) \\ E(z)[1 + G(z)] &= R(z) \end{aligned}$$

- Using the final value theorem (for discrete signals see slide 9):

$$e_{ss}^* = e^*(\infty) = \lim_{z \rightarrow 1} (1 - z^{-1}) E(z) = \lim_{z \rightarrow 1} (1 - z^{-1}) \frac{R(z)}{1 + G(z)} \quad (1)$$

- Unit Step Input:**  $R(z) = \frac{z}{z-1}$  Using formula (1)

$$e_{ss} = \lim_{z \rightarrow 1} \left( \frac{z-1}{z} \right) \frac{\left( \frac{z}{z-1} \right)}{1 + G(z)} = \frac{1}{1 + \lim_{z \rightarrow 1} G(z)} \Rightarrow e_{ss} = \frac{1}{1 + K_p} \quad \text{Where } K_p = \lim_{z \rightarrow 1} G(z)$$

- Unit Ramp Input:**  $R(z) = \frac{Tz}{(z-1)^2}$  Using formula (1)

$$e_{ss} = e(\infty) = \frac{1}{K_v} \quad \text{Where } K_v = \frac{1}{T} \lim_{z \rightarrow 1} (z-1)G(z)$$

- Unit Parabolic Input:**  $R(z) = \frac{T^2 z(z+1)}{2(z-1)^3}$  Using formula (1)

$$e_{ss} = e(\infty) = \frac{1}{K_a} \quad \text{Where } K_a = \frac{1}{T^2} \lim_{z \rightarrow 1} (z-1)^2 G(z)$$

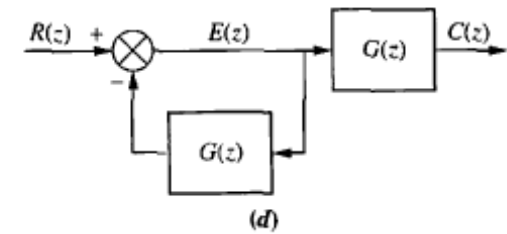
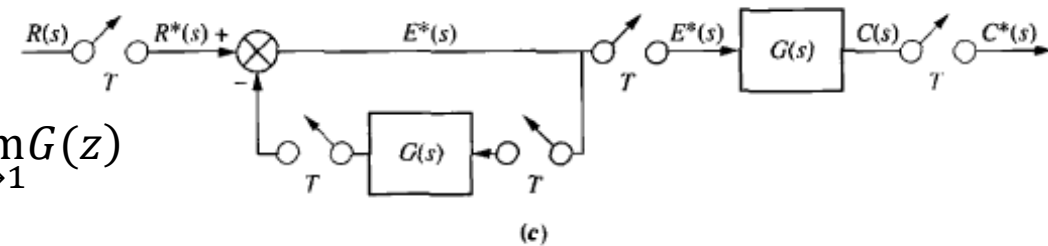
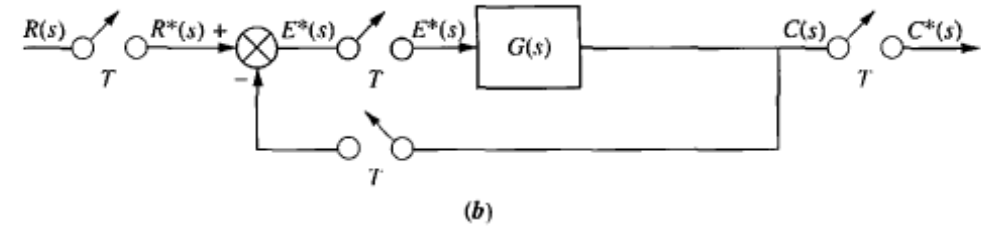
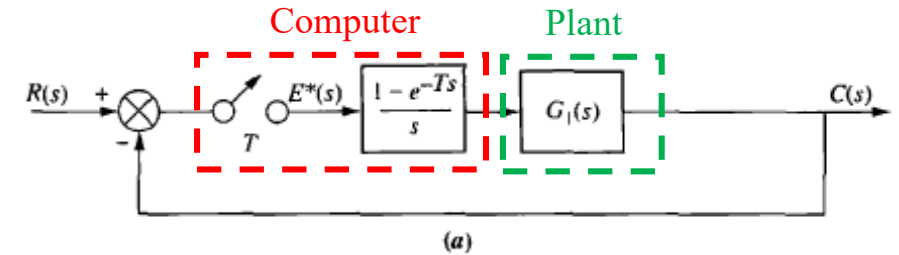

# Steady-State Errors

- The equations developed above for  $e^*(\infty)$ ,  $K_p$ ,  $K_v$ , and  $K_a$  are similar to the equations developed for analog systems.
- Multiple pole placement at the origin of the S-plane reduced steady-state errors to zero in the analog case.
- Multiple pole placement at  $z = 1$  reduces the steady-state error to zero for digital systems.  $s = 0$  maps into  $z = 1$  under  $z = e^{Ts}$

## Example

For step, ramp, and parabolic inputs, find the steady-state error

for the feedback control system shown in Figure if:  $G_1(s) = \frac{10}{s(s+1)}$

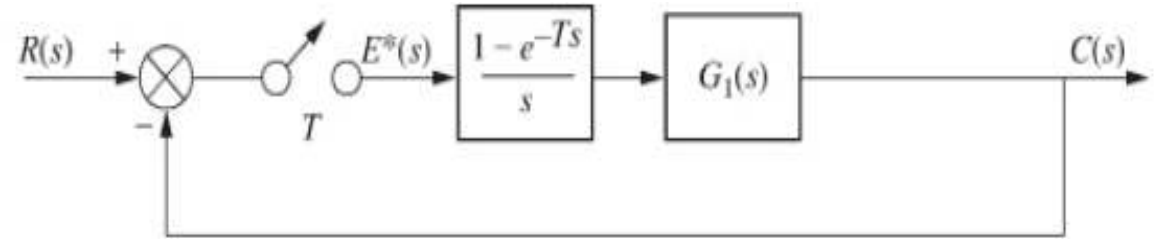

## SOLUTION

First find  $G(s)$ , the product of the z.o.h. and the plant.  $G(s) = \frac{10(1 - e^{-Ts})}{s^2(s+1)} = 10(1 - e^{-Ts}) \left[ \frac{1}{s^2} - \frac{1}{s} + \frac{1}{s+1} \right]$

The z-transform is then:  $G(z) = 10(1 - z^{-1}) \left[ \frac{Tz}{(z-1)^2} - \frac{z}{z-1} + \frac{z}{z - e^{-T}} \right] \Rightarrow G(z) = 10 \left[ \frac{T}{z-1} - 1 + \frac{z-1}{z - e^{-T}} \right]$

Thus:

1. For a step input:  $K_p = \lim_{z \rightarrow 1} G(z) = \infty \rightarrow e_{ss} = e^*(\infty) = \frac{1}{1+K_p} = 0$

2. For a ramp input:  $K_v = \frac{1}{T} \lim_{z \rightarrow 1} (z-1)G(z) = 10 \rightarrow e_{ss} = e^*(\infty) = \frac{1}{K_v} = 0.1$

3. For a parabolic input:  $K_a = \frac{1}{T^2} \lim_{z \rightarrow 1} (z-1)^2 G_1(z) = 0 \rightarrow e_{ss} = e^*(\infty) = \frac{1}{K_a} = \infty$

# Transient Response on the Z-Plane

- On the s-plane: vertical lines were lines of constant settling time, horizontal lines were lines of constant peak time, and radial lines were lines of constant percent overshoot.

$$T_r = \frac{1.8}{\omega}, \quad T_s = \frac{4}{\sigma}, \quad T_p = \frac{\pi}{\omega}, \quad \%OS = e^{-\frac{\xi\pi}{\sqrt{1-\xi^2}}}$$

- The transformation to z-domain:  $z = e^{sT}$ , for  $s = \sigma + j\omega$  we obtain  $z = e^{sT} = e^{(\sigma+j\omega)T} = e^{\sigma T} e^{j\omega T} = r e^{j\omega T}$

- Constant settling time** are concentric circles of radius  $r$ .

for  $T_s = const = \frac{4}{\sigma} \rightarrow \sigma = const \rightarrow r = const$ .

- Constant peak time** for  $s = \sigma + j\omega$  we obtain

$$T_p = const = \frac{\pi}{\omega} \rightarrow \omega = \frac{\pi}{T_p} = const \rightarrow \text{Radial lines at an angle } \omega T = \theta_1 = \pi \frac{T}{T_p}$$

- Constant percent overshoot** we obtain curves on the z-plane. radial lines in the S-plane are represented by:

$$\frac{\sigma}{\omega} = -\tan(\sin^{-1}\xi) = -\frac{\xi\omega_n}{\omega_n\sqrt{1-\xi^2}} = \frac{\xi}{\sqrt{1-\xi^2}}$$

$$s = \sigma + j\omega = -\omega_n\xi + j\omega_n\sqrt{1-\xi^2} \xrightarrow{\text{Transforming to Z-plane}} z = e^{sT} = e^{-\zeta\omega_n T} e^{j\omega_n\sqrt{1-\xi^2}T}$$

Radius and phase depend on  $\xi$

- For a desired damping ratio,  $\xi$ , curves can then be used as constant percent overshoot curves on the z-plane through a range of  $\omega T$  (see previous slide).

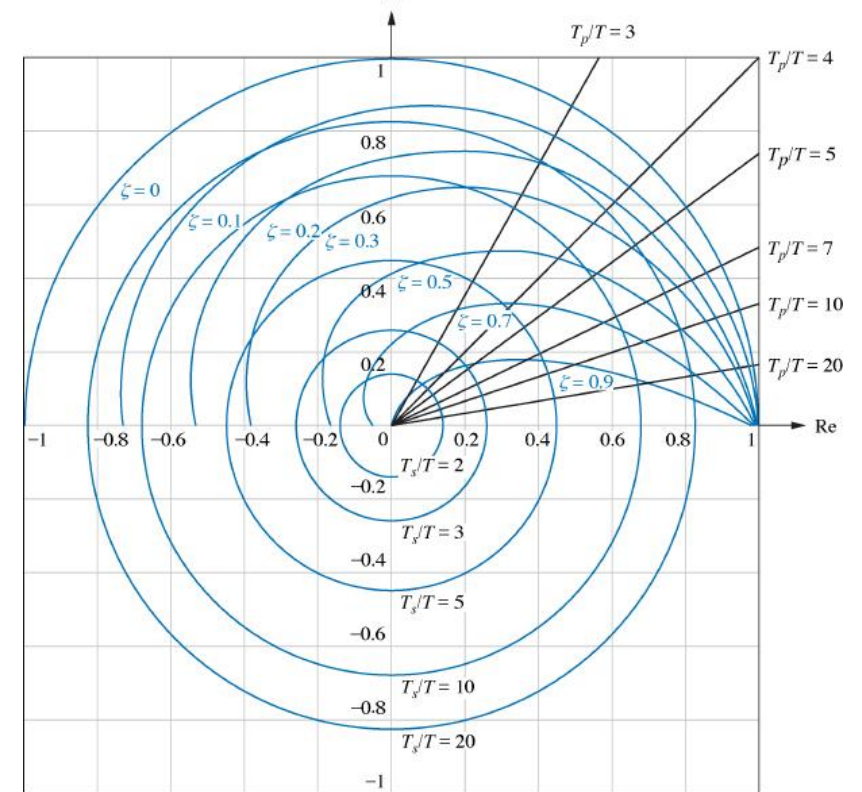

Fig (a) Constant damping ratio, normalized (to the sampling interval) settling time, and normalized peak time plots on the z-plane

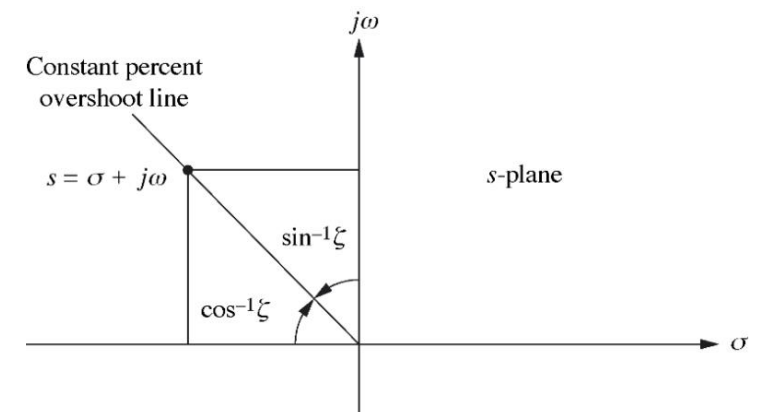

Fig. The s-plane sketch of constant percent overshoot line

# Design Gain (P-Controller) via Root Locus

- Plot root locus (*in z plane use the same rules as in s plane*) and determine the gain required for stability (*within the unit circle*) as well as the gain required to meet a transient response requirement (*find the intersection of the root locus with the appropriate curves as they appear on the z-plane*).

## Example (Stability Design via Root Locus)

Sketch the root locus for the system shown in Figure (a). Also, determine the range of gain,  $K$ , for stability from the root locus plot.

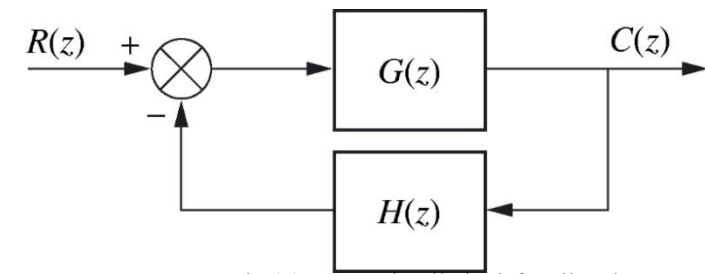

Fig(a) Generic digital feedback

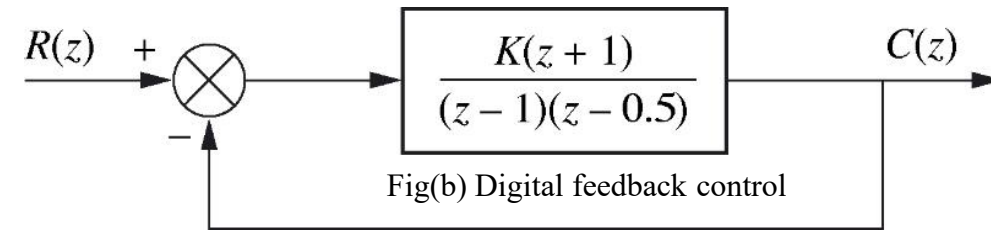

Fig(b) Digital feedback control

### SOLUTION

- Sketch the root locus (use  $z$  as  $s$ ), the results in Figure (b) using Matlab.
- Search along the unit circle for  $180^\circ$ , the intersection of the root locus with the unit circle is  $1 \angle 60^\circ$  with gain  $K = 0.5$ . Hence, the range of gain for stability is  $0 < K < 0.5$ .
- In general, if the open-loop transfer function is given by:

$$K G(z) = K \frac{z + \gamma}{(z + \alpha)(z + \beta)}$$

then



The root locus is a circle with center  $z_0 = (-\gamma, 0)$  with the radius  $r = \sqrt{(\gamma - \alpha)(\gamma - \beta)}$

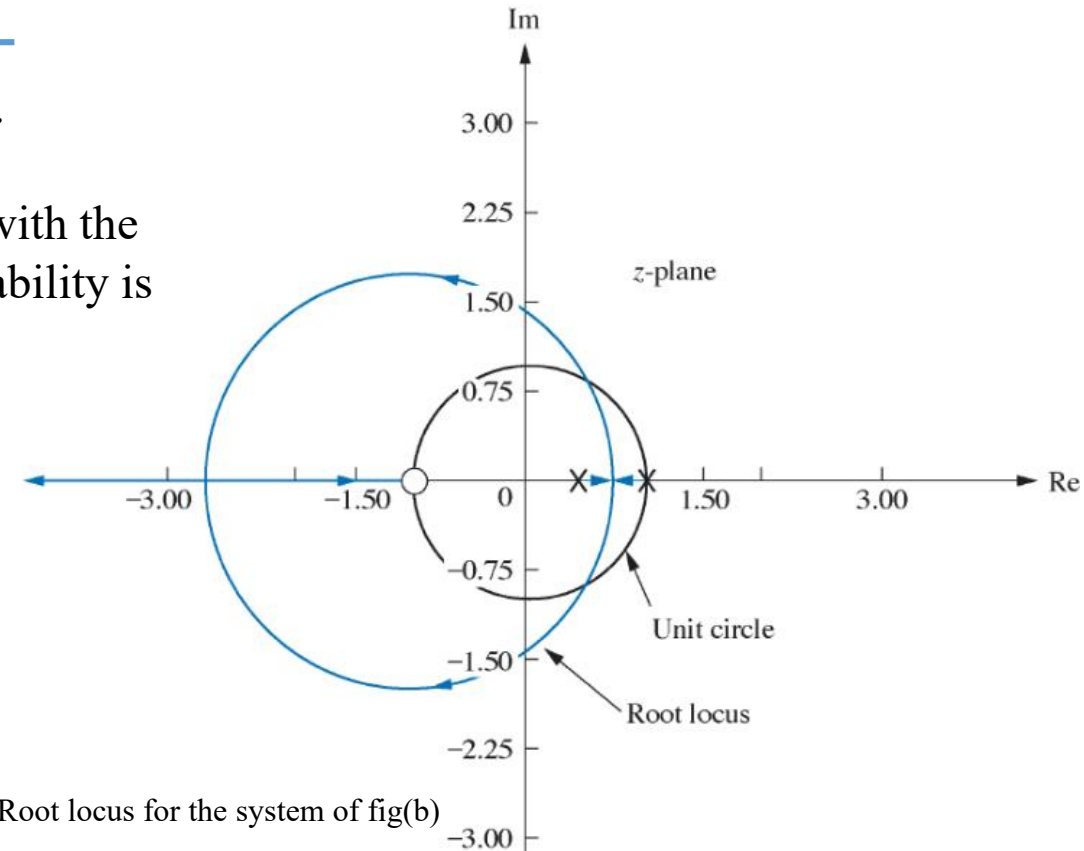

Fig(c) Root locus for the system of fig(b)

# Example (Transient Response Design via Gain Adjustment)

For the system of the previous example, find the value of gain,  $K$ , to yield a damping ratio of 0.7.

## SOLUTION

- Figure (a) shows the constant damping ratio curves superimposed over the root locus for the system as determined from the last example.
- We obtain the gain by searching along a  $16.62^\circ$  radial line for  $180^\circ$  (intersection point of the 0.7 damping ratio curve with the  $16.62^\circ$  radial line). At this point  $K = 0.0627$  at  $0.719 + j 0.2153$ .
- We can now check our design by finding the unit sampled step response of the system Using our design,  $K = 0.0627$ .

Input:  $R(z) = z/(z - 1)$ , sampled unit step

the sampled output 
$$C(z) = \frac{R(z)G(z)}{1 + G(z)} = \frac{0.0627 z^2 + 0.0627 z}{z^3 - 2.4373 z^2 + 2 z - 0.5627}$$

- Since the overshoot is approximately 5%, the requirement of a 0.7 damping ratio has been met Figure (b).

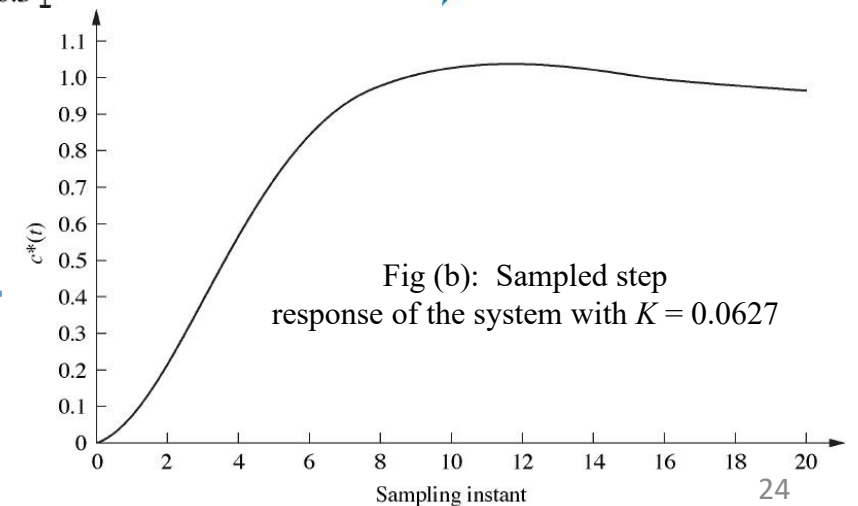
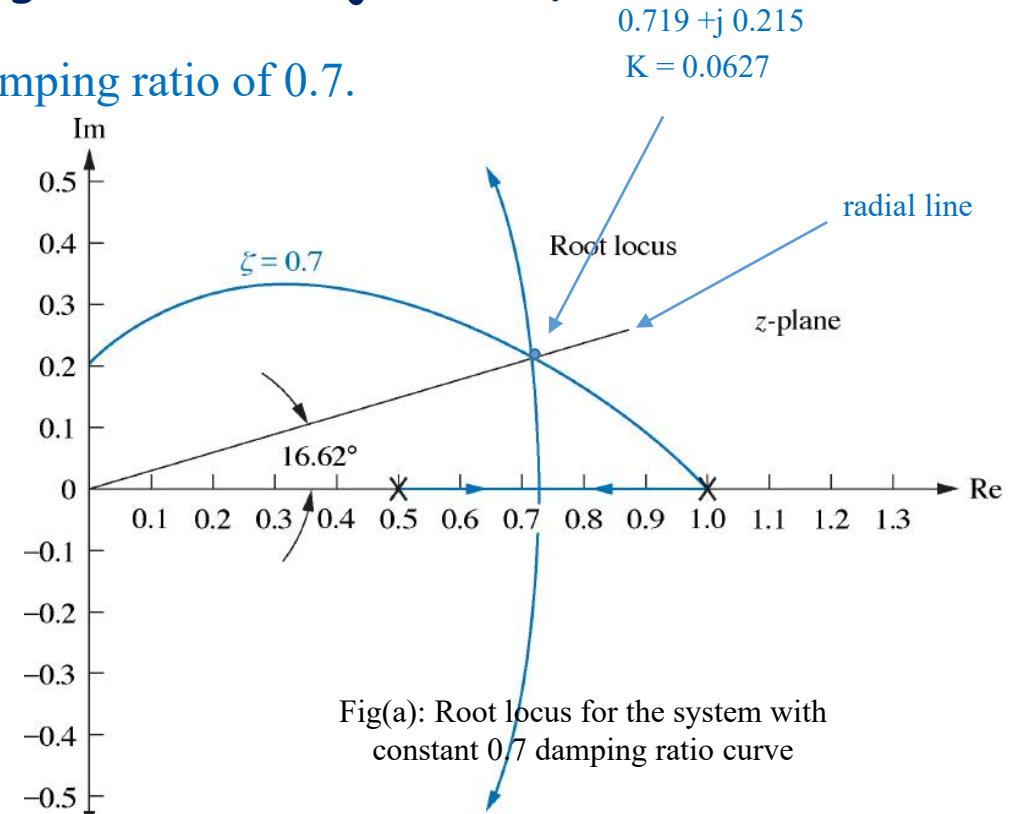

Note: Valid only at integer values of sampling instant

# 10 Cascade Compensation via the s-Plane

- Rather than designing directly in the z-domain, we can design on the s-plane, using S-plane analysis, and then convert the continuous compensator to a digital compensator using the *bilinear transformation*.
- A bilinear transformation that yields a digital transfer function whose output response at the sampling instants is approximately the same as the equivalent analog transfer function is called the *Tustin transformation*.
- *Tustin transformation* is used to transform the continuous compensator,  $G_c(s)$ , to the digital compensator,  $G_c(z)$ , by:

*Tustin transformation*

$$s = \frac{2(z-1)}{T(z+1)}$$

*Inverse Tustin transformation*

$$z = \frac{-\left(s + \frac{2}{T}\right)}{\left(s - \frac{2}{T}\right)} = \frac{1 + \frac{T}{2}s}{1 - \frac{T}{2}s}$$

- As the sampling interval,  $T$ , gets smaller (higher sampling rate), the designed digital compensator's output yields a closer match to the analog compensator.

## Example (Digital Cascade Compensator Design)

For the digital control system of Figure(a), where the plant  $G_p(s)$  is given, design a digital lead compensator,  $G_c(z)$ , as shown in Figure (b), so that the system will operate with 20% overshoot and a settling time of 1.1 seconds. Create your design in the s-domain and transform the compensator to the z-domain (Sampling period  $T=0.01$  second).

$$G_p(s) = \frac{1}{s(s+6)(s+10)}$$

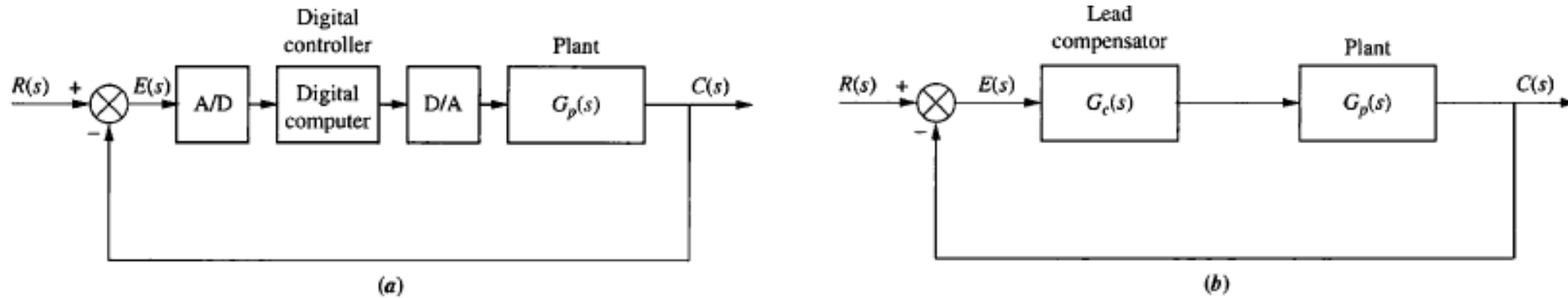

FIGURE a. Digital control system showing the digital computer performing compensation; b. continuous system used for design;

## SOLUTION

Using Figure(b), design a lead compensator using the techniques described previously. The design was created as part of an Example, where we found that the lead compensator was (see previous chapters)

$$G_c(s) = \frac{1977(s+6)}{(s+29.1)}$$

- We have the analog compensator transfer function  $G_c(s) = \frac{1977(s + 6)}{(s + 29.1)}$
- Using *Tustin transformation* with  $T = 0.01$   $s = \frac{2(z - 1)}{T(z + 1)}$  Yields to the digital compensator TF  $G_c(z) = \frac{1778z - 1674}{z - 0.746}$
- The z-transform of the plant and zero-order hold, with  $T = 0.01$  second, is  $G_p(z) = \frac{(1.602 \times 10^{-7}z^2) + (6.156 \times 10^{-7}z) + (1.478 \times 10^{-7})}{z^3 - 2.847z^2 + 2.699z - 0.8521}$

- The transformed digital system

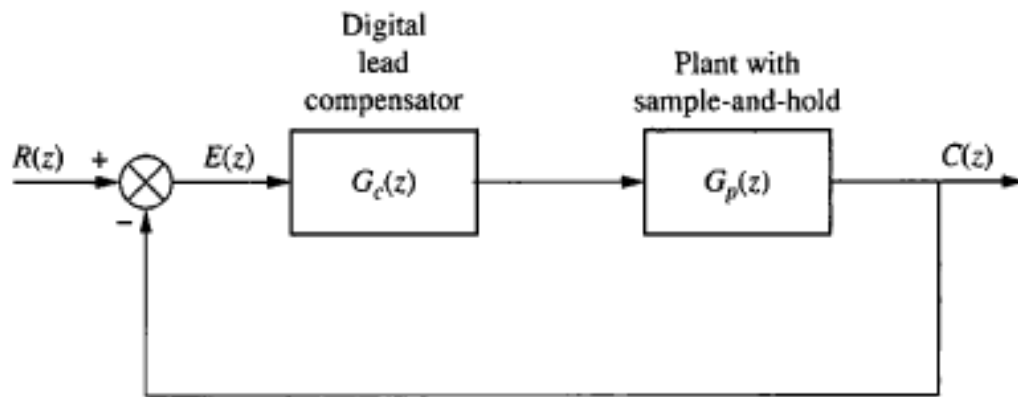

- The time response in Figure ( $T = 0.01$  s) shows that the compensated closed-loop system meets the transient response requirements. The figure also shows the response for a compensator designed with sampling times at the extremes of Astrom and Wittenmark's guideline.

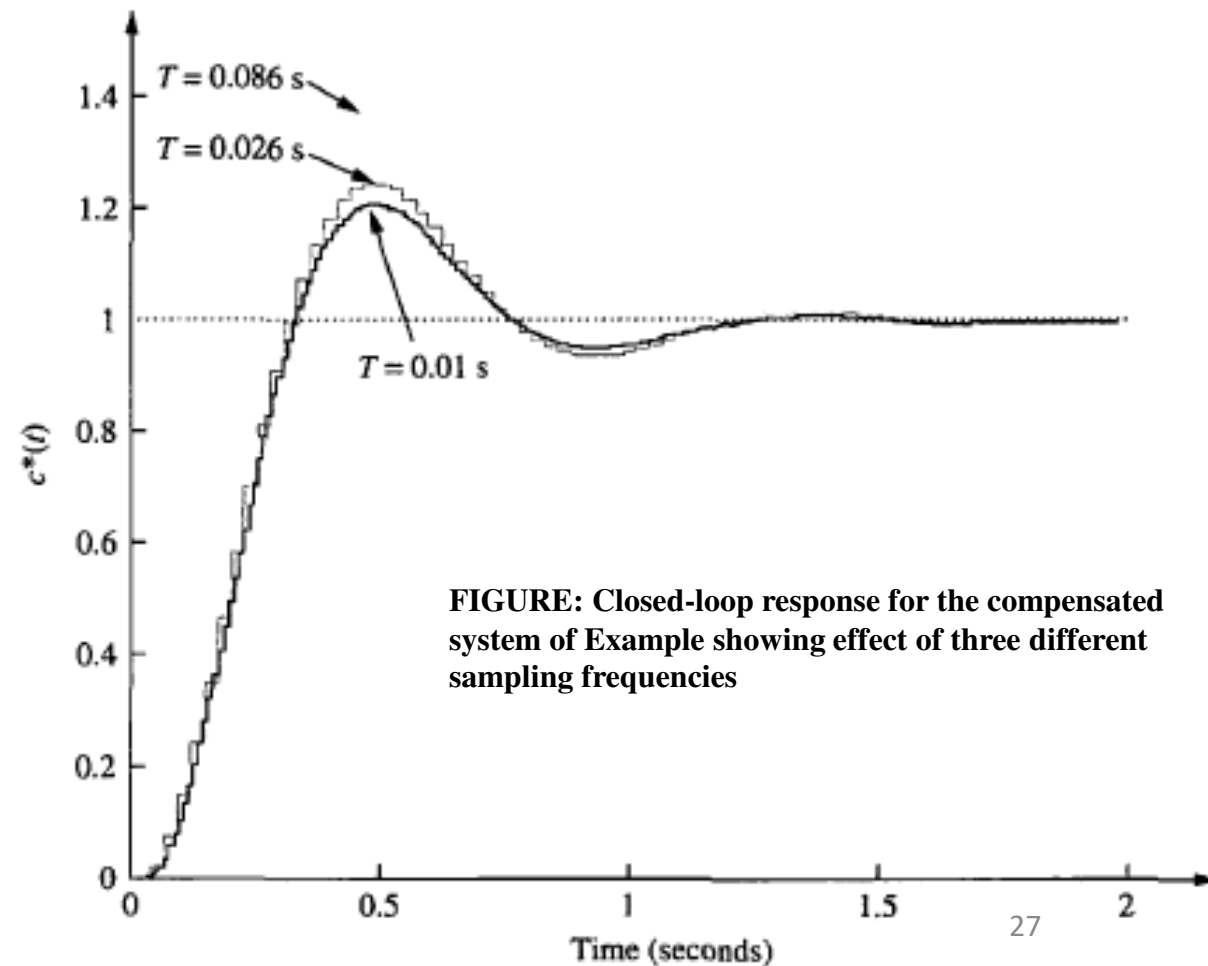

**FIGURE: Closed-loop response for the compensated system of Example showing effect of three different sampling frequencies**