Logic and Computer Design Fundamentals

Counters, Serial Operations

Charles Kime & Thomas Kaminski

© 2008 Pearson Education, Inc.
(Hyperlinks are active in View Show mode)

Overview

- **Part 1 – Registers, Microoperations and Implementations**
- **Part 2 – Counters, register cells, buses, & serial operations**
 - **Microoperations on single register (continued)**
 - **Counters**
 - **Register cell design**
 - **Multiplexer and bus-based transfers for multiple registers**
 - **Serial transfers and microoperations**
- **Part 3 – Control of Register Transfers**

Counters

- **Counters** are sequential circuits which "count" through a specific state sequence. They can **count up**, **count down**, or **count through other fixed sequences**. Two distinct types are in common usage:

1. **Ripple Counters**

- **Clock connected to the flip-flop clock input on the LSB bit flip-flop**
- **For all other bits, a flip-flop output is connected to the clock input, thus circuit is not truly synchronous!**
- **Output change is delayed more for each bit toward the MSB.**
- **Resurgent because of low power consumption**

2. **Synchronous Counters**

- **Clock is directly connected to the flip-flop clock inputs**
- **Logic is used to implement the desired state sequencing**

Ripple Counter

- **How does it work?**
 - **When there is a positive edge on the clock input of A, A complements**
 - **The clock input for flip-flop B is the complemented output of flip-flop A**
 - **When flip A changes from 1 to 0, there is a positive edge on the clock input of B causing B to complement**

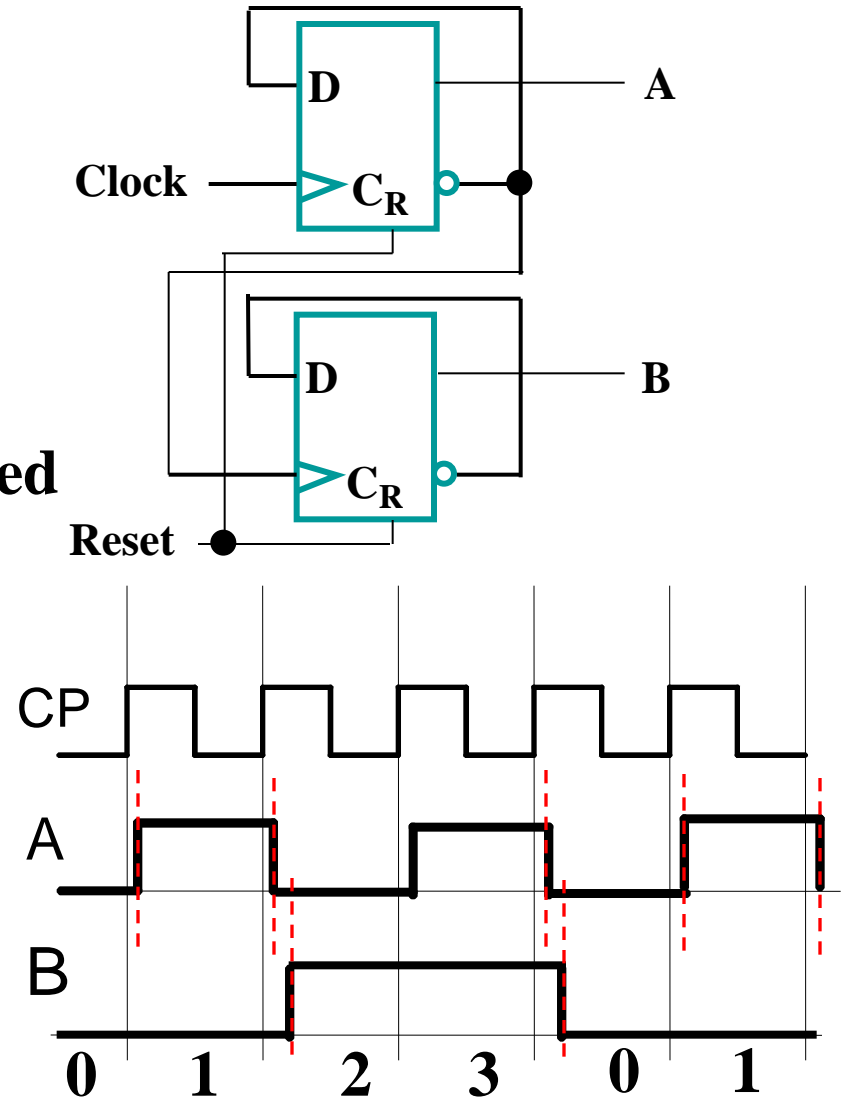

4-Bit Ripple Counter

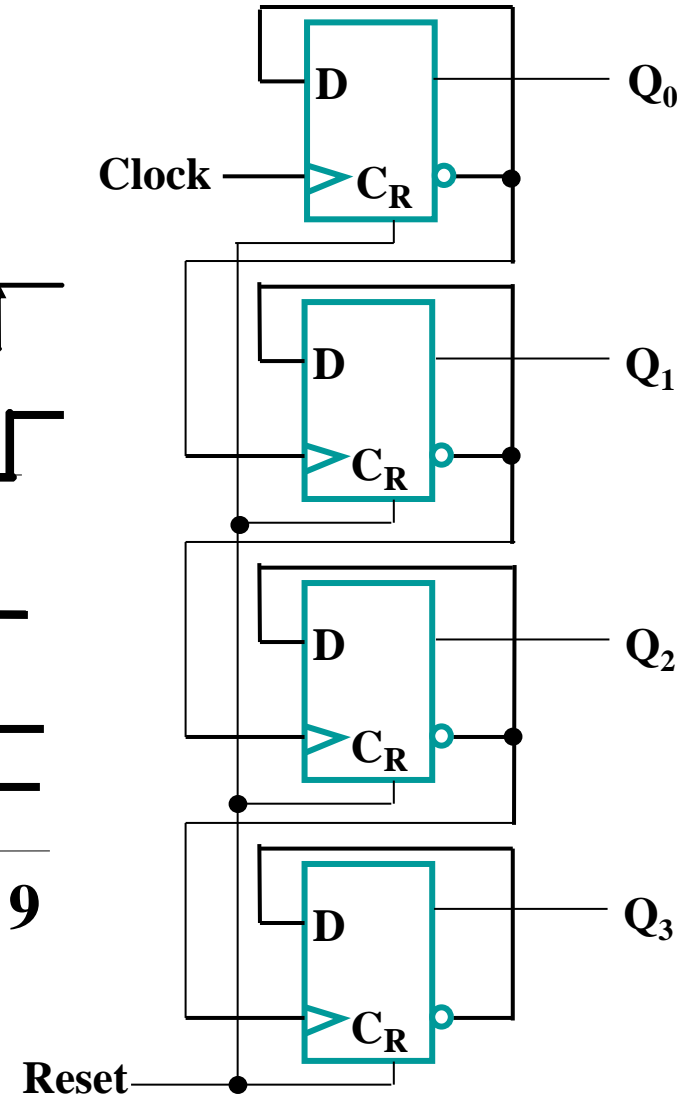
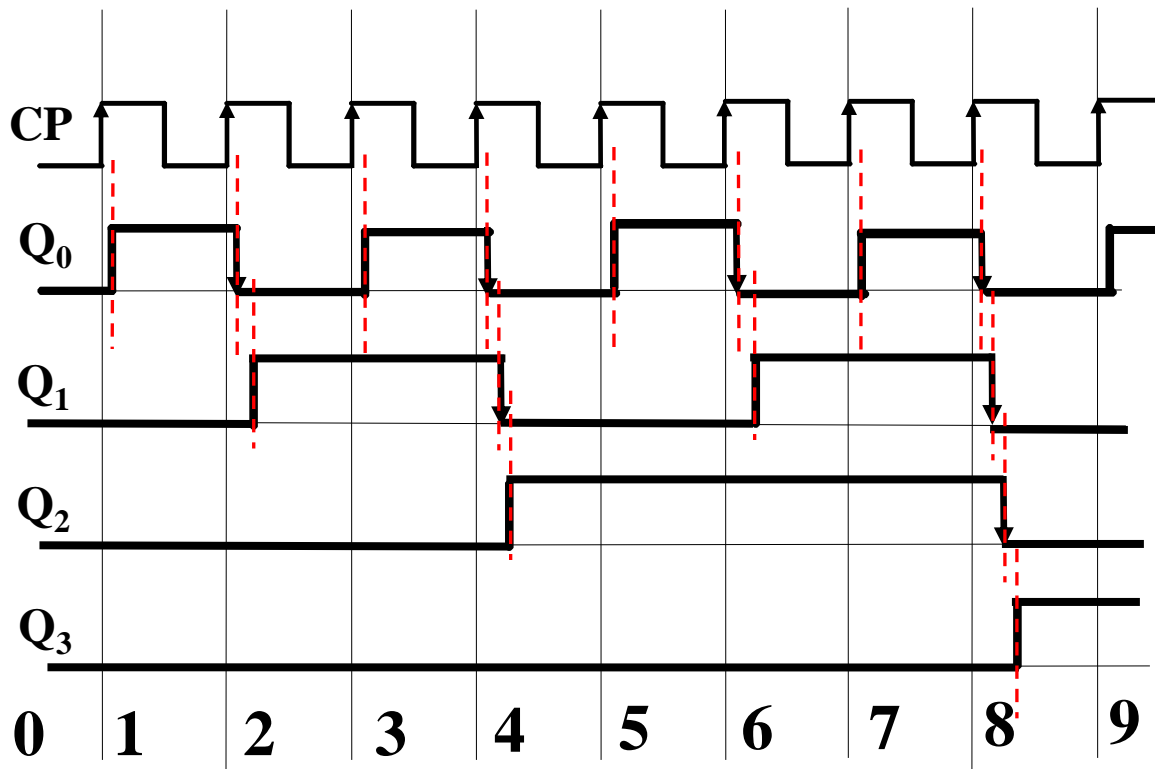

4-Bit Ripple Counter

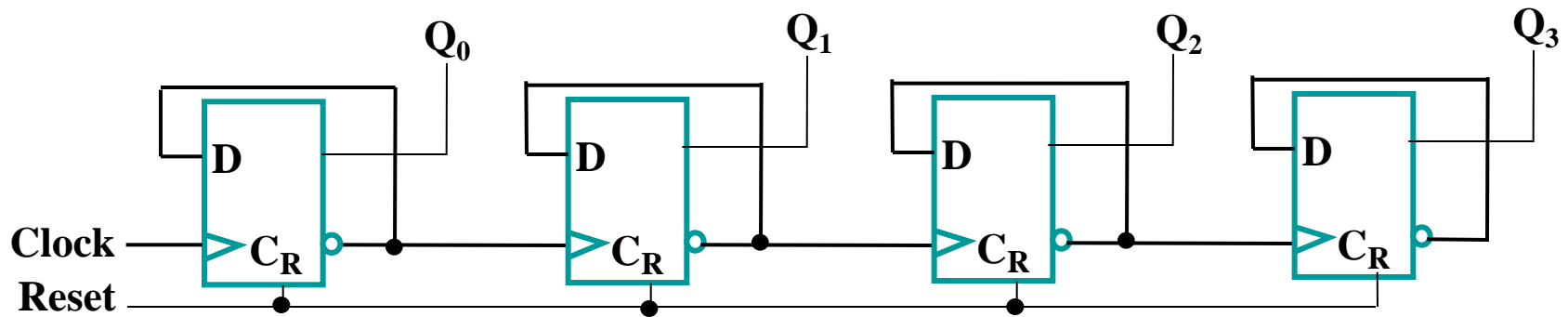

Ripple Counter (continued)

- **The arrows show the cause-effect relationship from the prior slide =>**

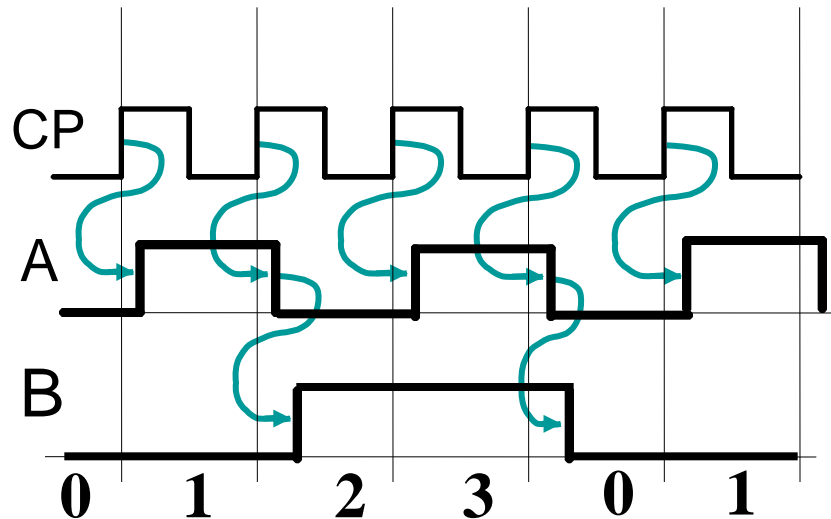

- **The corresponding sequence of states =>**

$(B,A) = (0,0), (0,1), (1,0), (1,1), (0,0), (0,1), \dots$

- **Each additional bit, C, D, ...behaves like bit B, changing half as frequently as the bit before it.**
- **For 3 bits: $(C,B,A) = (0,0,0), (0,0,1), (0,1,0), (0,1,1), (1,0,0), (1,0,1), (1,1,0), (1,1,1), (0,0,0), \dots$**

Ripple Counter (continued)

- These circuits are called *ripple counters* because each edge sensitive transition (positive in the example) causes a change in the next flip-flop's state.
- The changes “ripple” upward through the chain of flip-flops, i. e., each transition occurs after a clock-to-output delay from the stage before.

Ripple Counter (continued)

- Starting with $C = B = A = 1$, equivalent to $(C,B,A) = 7$ base 10, the next clock increments the count to $(C,B,A) = 0$ base 10. In fine timing detail:

- The clock to output delay t_{PHL} causes an increasing delay from clock edge for each stage transition.
- Thus, the count “ripples” from least to most significant bit.
- For n bits, total worst case delay is $n t_{PHL}$.**

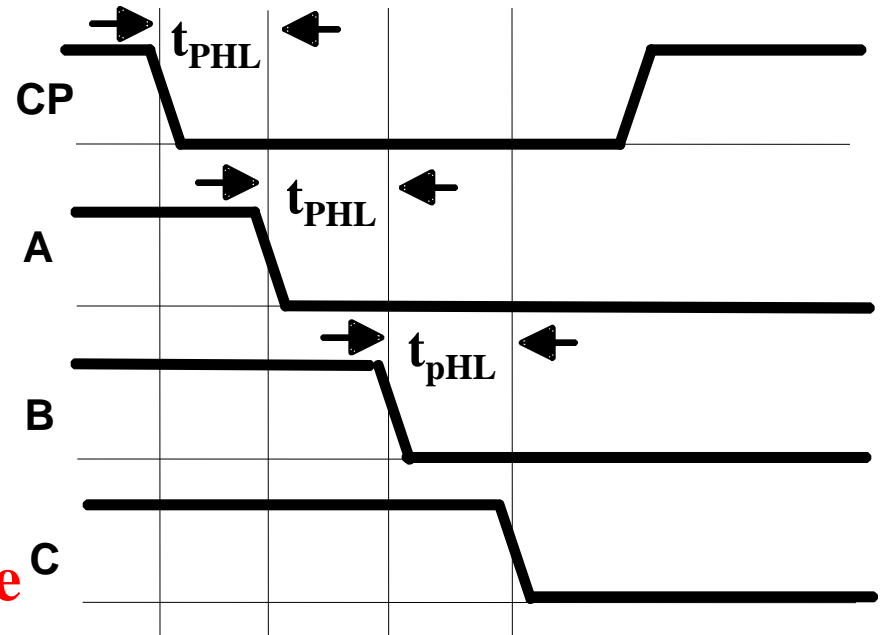

Synchronous Counters

- **To eliminate the "ripple" effects**, use a common clock for each flip-flop and a combinational circuit to generate the next state.
- For an up-counter, use an **incrementer**.

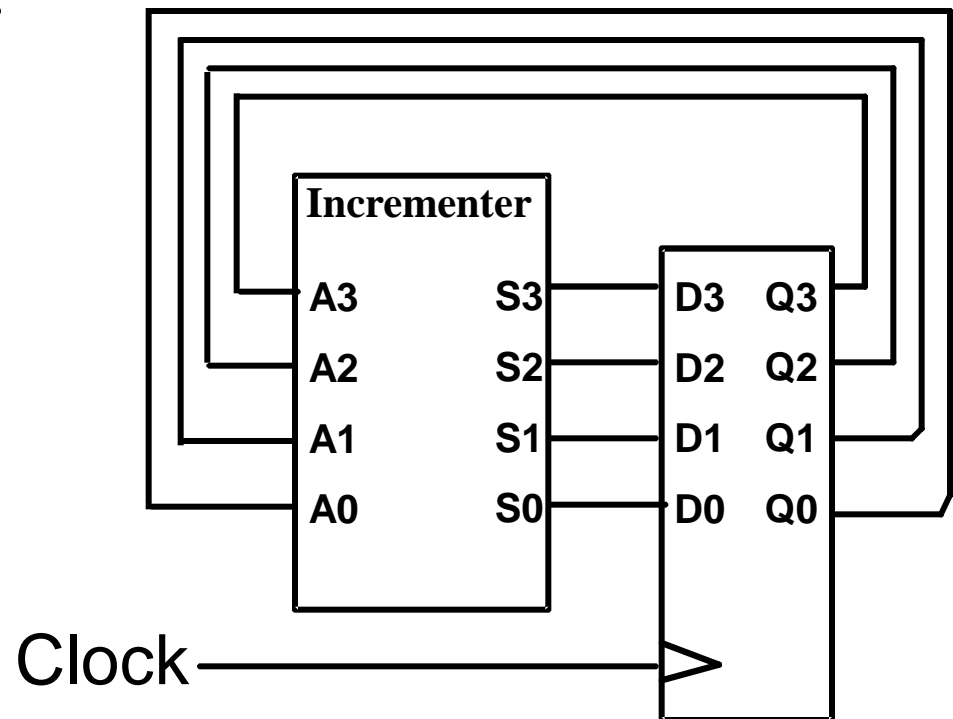

Synchronous Counters (continued)

- **Internal details** => Incrementer
- **Internal Logic**
 - **XOR complements each bit**
 - **AND chain causes complement of a bit if all bits toward LSB from it equal 1**
- **Count Enable**
 - **Forces all outputs of AND chain to 0 to “hold” the state**
- **Carry Out**
 - **Added as part of incrementer**
 - **Connect to Count Enable of additional 4-bit counters to form larger counters**

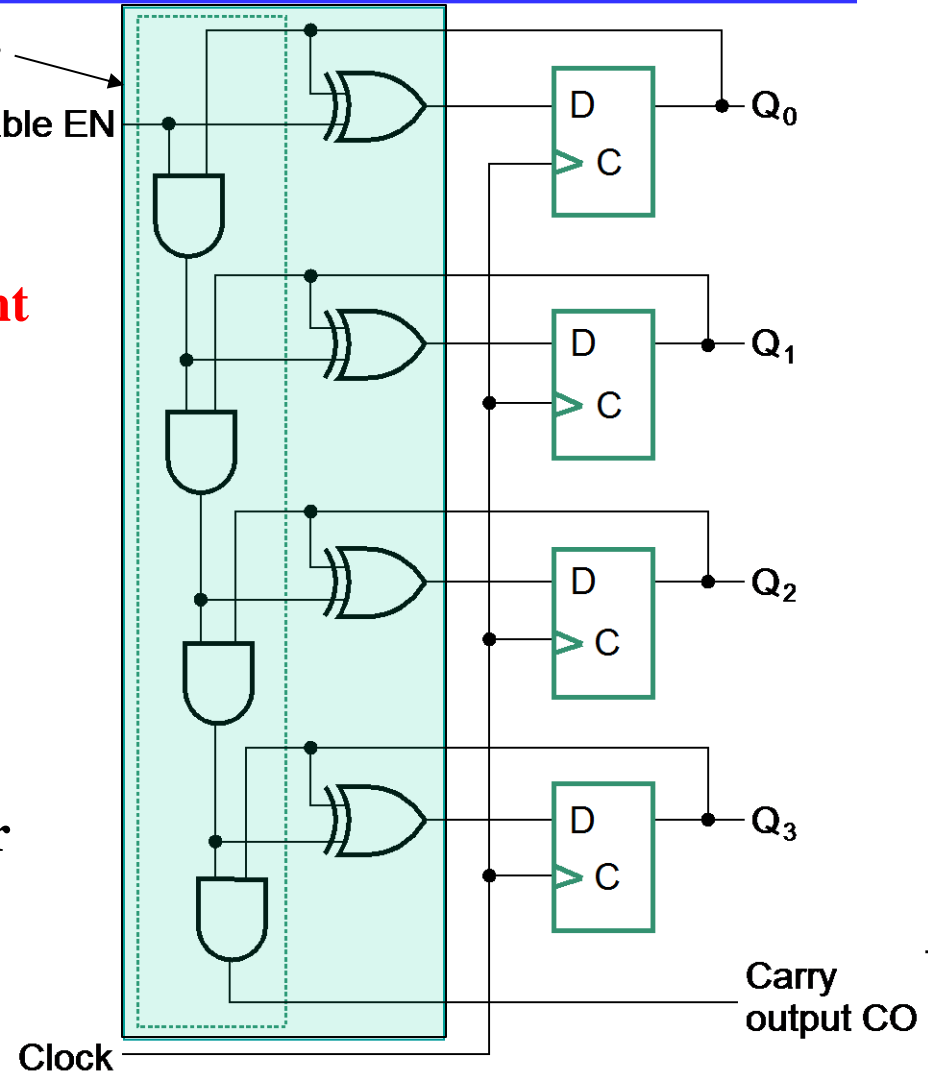

(a) Logic Diagram-Serial Gating

Synchronous Counters

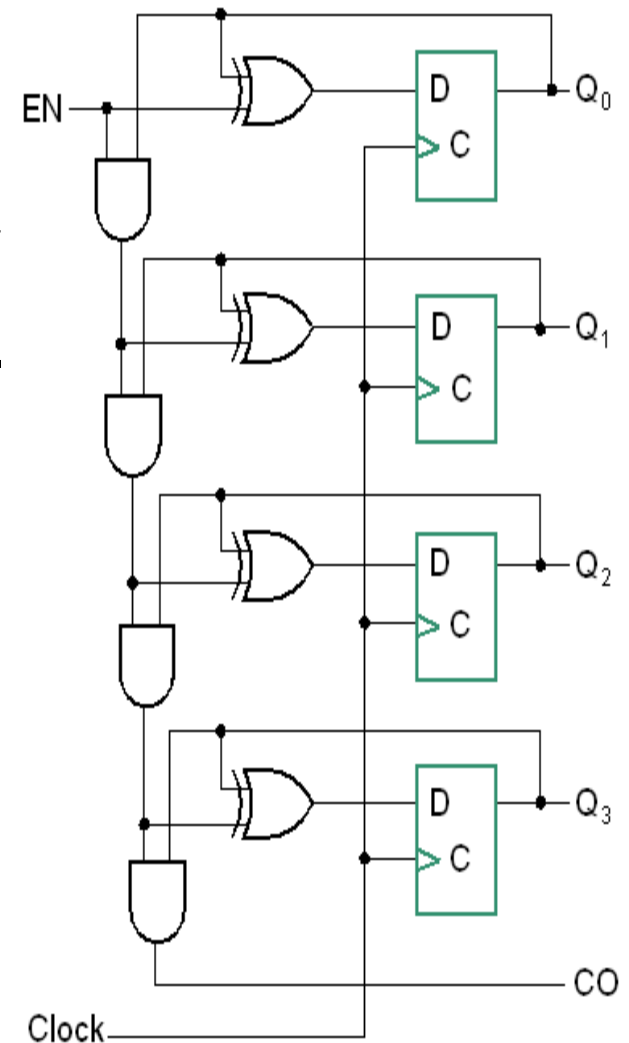
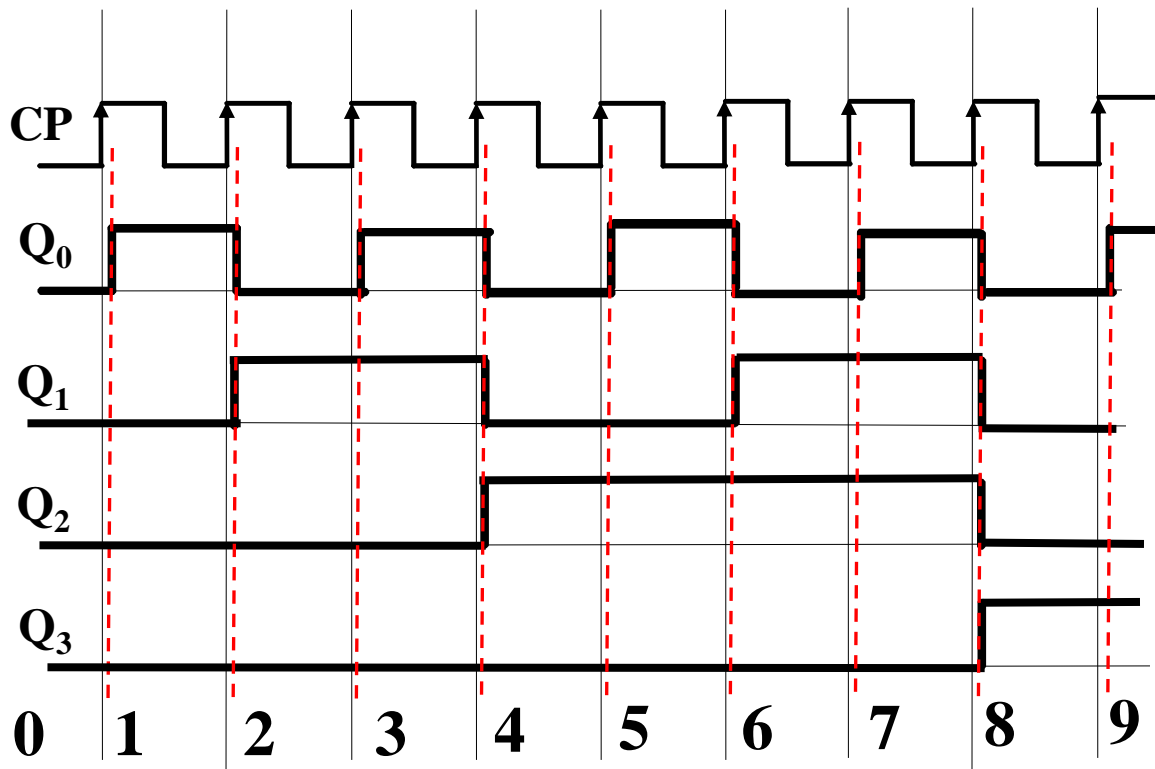

Synchronous Counters (continued)

- **Carry chain**
 - series of AND gates through which the carry “ripples”
 - Yields long path delays
 - Called *serial gating*
- **Replace AND carry chain with ANDs => in parallel**
 - Reduces path delays
 - Called *parallel gating*
 - Like carry lookahead
 - Lookahead can be used on COs and ENs to prevent long paths in large counters
- **Symbol for Synchronous Counter**

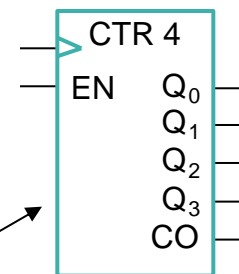

Symbol

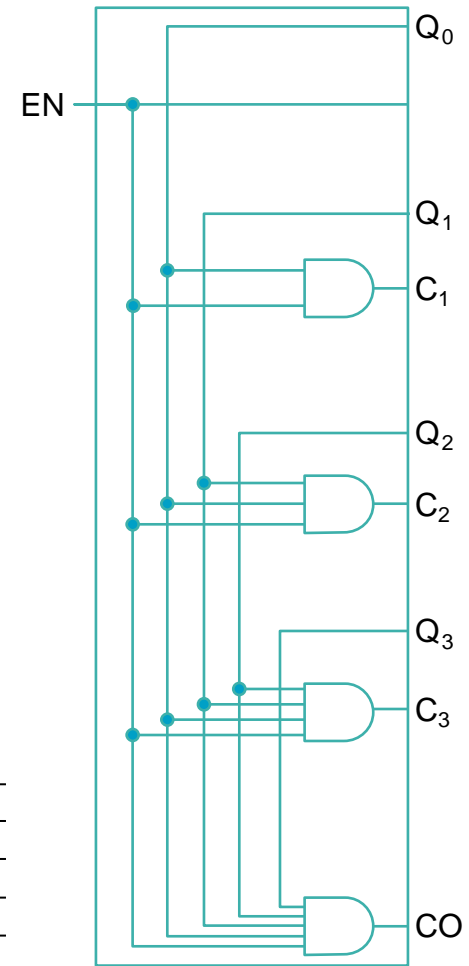

Logic Diagram-Parallel Gating

Other Counters

- See text for:
 - ***Down Counter*** - counts downward instead of upward
 - ***Up-Down Counter*** - counts up or down depending on value a control input such as Up/Down
 - ***Parallel Load Counter*** - Has parallel load of values available depending on control input such as Load
- ***Divide-by- n (Modulo n) Counter***
 - Count is remainder of division by n ; n may not be a power of 2 or
 - Count is arbitrary sequence of n states specifically designed state-by-state
 - Includes modulo 10 which is the *BCD counter*

Counter with Parallel Load

- Add path for input data
 - enabled for Load = 1
- Add logic to:
 - disable count logic for Load = 1
 - disable feedback from outputs for Load = 1
 - enable count logic for Load = 0 and Count = 1
- The resulting function table:

Load	Count	Action
0	0	Hold Stored Value
0	1	Count Up Stored Value
1	X	Load D

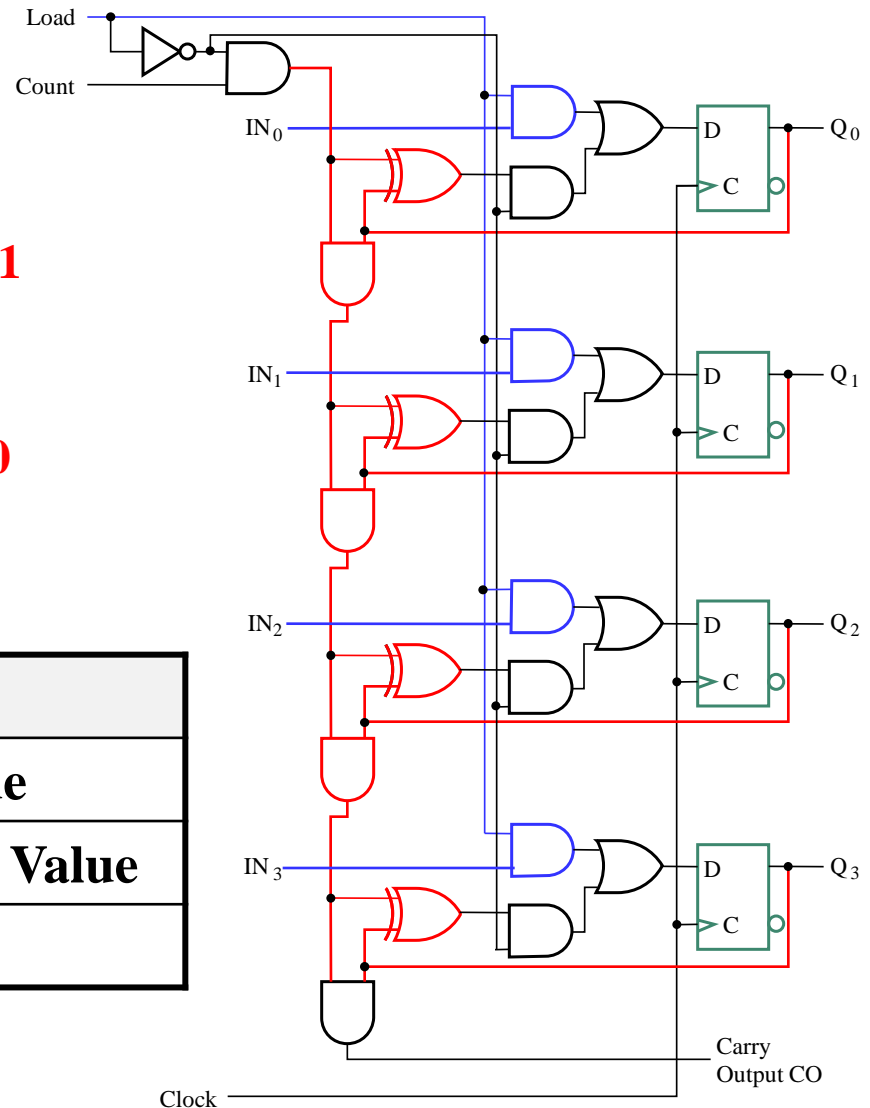

Counter with Parallel Load

- Add path for input data
 - enabled for Load = 1
- Add logic to:
 - disable count logic for Load = 1
 - disable feedback from outputs for Load = 1
 - enable count logic for Load = 0 and Count = 1
- The resulting function table:

Load	Count	Action
0	0	Hold Stored Value
0	1	Count Up Stored Value
1	X	Load D

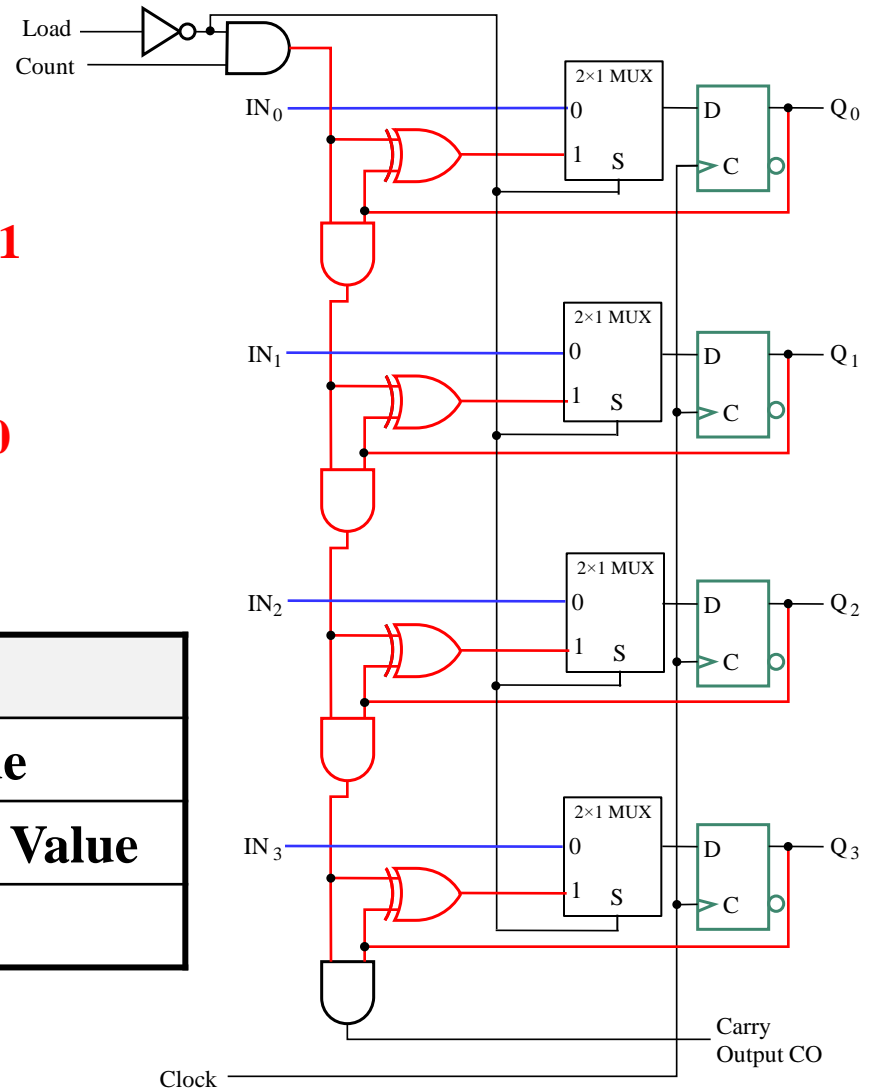

Design Example: Synchronous BCD

- Use the sequential logic model to design a synchronous BCD counter with D flip-flops
- State Table =>
- Input combinations 1010 through 1111 are don't cares

Current State				Next State			
Q8	Q4	Q2	Q1	Q8	Q4	Q2	Q1
0	0	0	0	0	0	0	1
0	0	0	1	0	0	1	0
0	0	1	0	0	0	1	1
0	0	1	1	0	1	0	0
0	1	0	0	0	1	0	1
0	1	0	1	0	1	1	0
0	1	1	0	0	1	1	1
0	1	1	1	1	0	0	0
1	0	0	0	1	0	0	1
1	0	0	1	0	0	0	0

Synchronous BCD (continued)

Current State	Next State
Q8 Q4 Q2 Q1	Q8 Q4 Q2 Q1
0 0 0 0	0 0 0 1
0 0 0 1	0 0 1 0
0 0 1 0	0 0 1 1
0 0 1 1	0 1 0 0
0 1 0 0	0 1 0 1
0 1 0 1	0 1 1 0
0 1 1 0	0 1 1 1
0 1 1 1	1 0 0 0
1 0 0 0	1 0 0 1
1 0 0 1	0 0 0 0

Present State	Next State
Q8 Q4 Q2 Q1	Q8 Q4 Q2 Q1
1 0 1 0	1 0 1 1
1 0 1 1	0 1 1 0
1 1 0 0	1 1 0 1
1 1 0 1	0 1 0 0
1 1 1 0	1 1 1 1
1 1 1 1	0 0 1 0

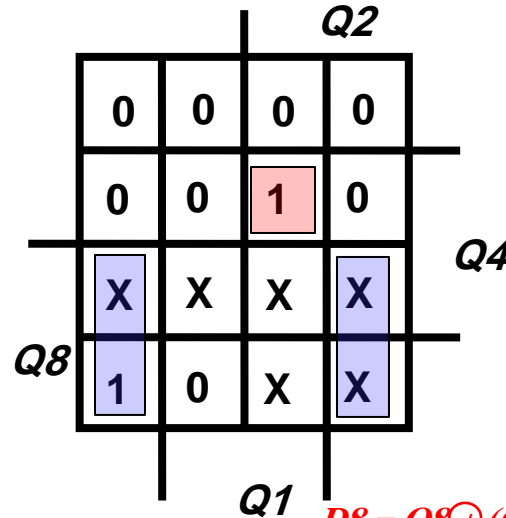

$$D8 = Q8 \oplus (Q1Q8 + Q1Q2Q4)$$

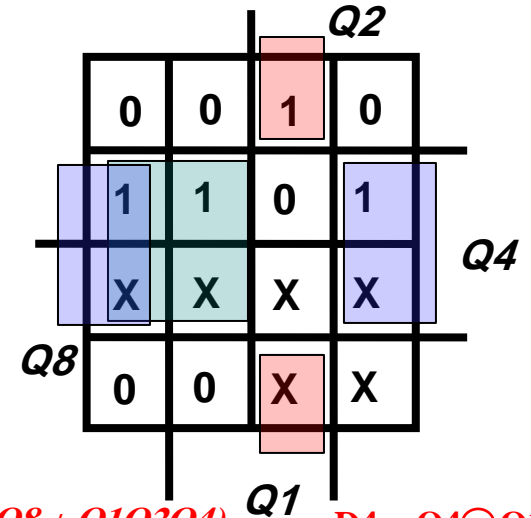

$$D4 = Q4 \oplus Q1Q2$$

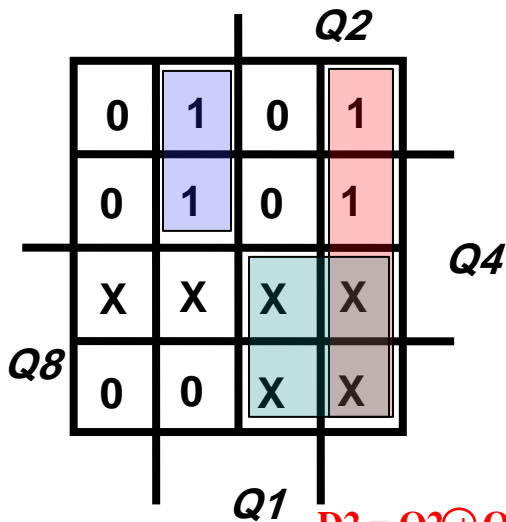

$$D2 = Q2 \oplus Q1\bar{Q8}$$

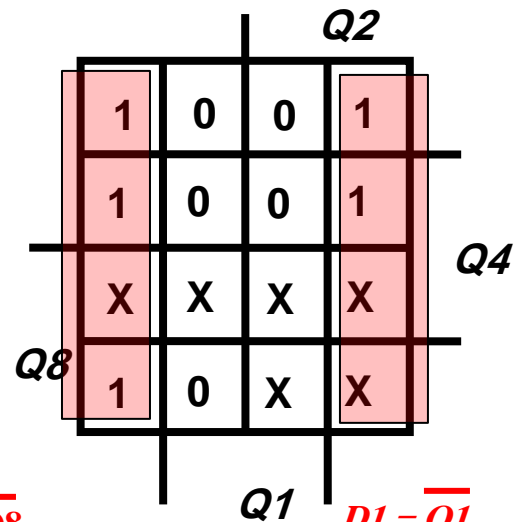

$$D1 = \bar{Q1}$$

Synchronous BCD (continued)

- Use K-Maps to two-level optimize the next state equations and manipulate into forms containing XOR gates:

$$D1 = \overline{Q_1}$$

$$D2 = Q_2 \oplus Q_1 \overline{Q_8}$$

$$D4 = Q_4 \oplus Q_1 Q_2$$

$$D8 = Q_8 \oplus (Q_1 Q_8 + Q_1 Q_2 Q_4)$$

- The logic diagram can be draw from these equations
 - An asynchronous or synchronous reset should be added
- What happens if the counter is perturbed by a **power disturbance** or other interference and it enters a state **other than 0000 through 1001**?

Synchronous BCD (continued)

- Find the actual values of the six next states for the don't care combinations from the equations
- Find the overall state diagram to assess behavior for the don't care states (states in decimal)

Present State				Next State			
Q8	Q4	Q2	Q1	Q8	Q4	Q2	Q1
1	0	1	0	1	0	1	1
1	0	1	1	0	1	1	0
1	1	0	0	1	1	0	1
1	1	0	1	0	1	0	0
1	1	1	0	1	1	1	1
1	1	1	1	0	0	1	0

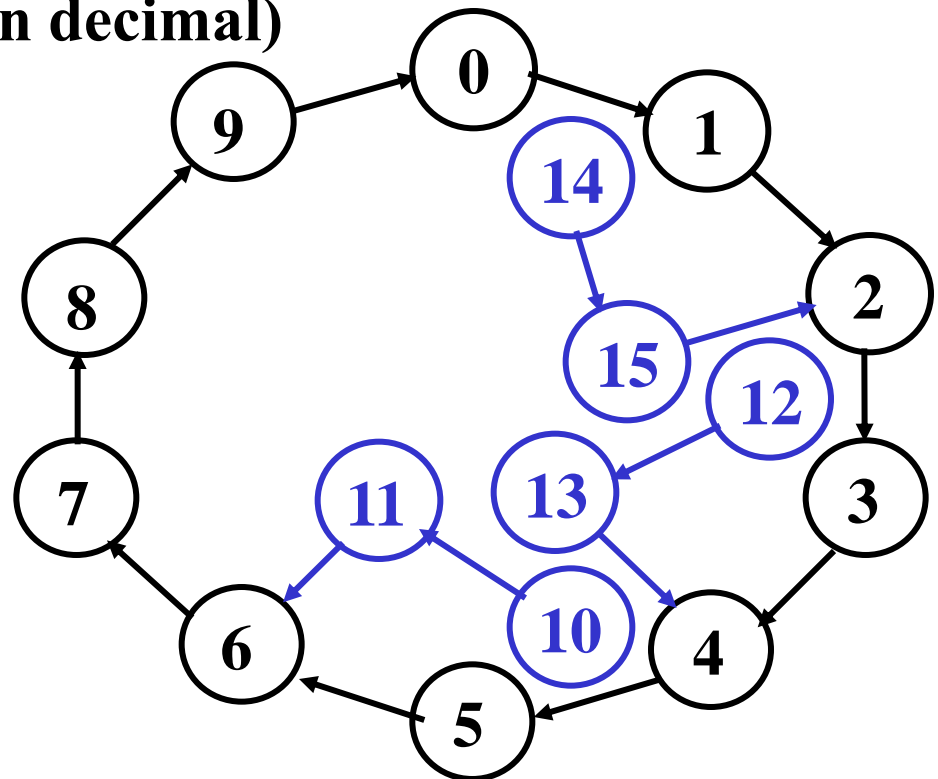

Synchronous BCD (Another Solution)

Current State	Next State
Q8 Q4 Q2 Q1	Q8 Q4 Q2 Q1
0 0 0 0	0 0 0 1
0 0 0 1	0 0 1 0
0 0 1 0	0 0 1 1
0 0 1 1	0 1 0 0
0 1 0 0	0 1 0 1
0 1 0 1	0 1 1 0
0 1 1 0	0 1 1 1
0 1 1 1	1 0 0 0
1 0 0 0	1 0 0 1
1 0 0 1	0 0 0 0

Present State	Next State
Q8 Q4 Q2 Q1	Q8 Q4 Q2 Q1
1 0 1 0	1 0 1 1
1 0 1 1	0 1 0 0
1 1 0 0	1 1 0 1
1 1 0 1	0 1 0 0
1 1 1 0	1 1 1 1
1 1 1 1	1 0 0 0

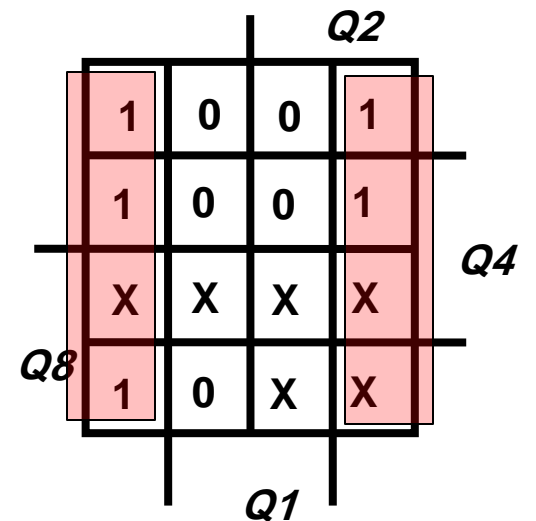
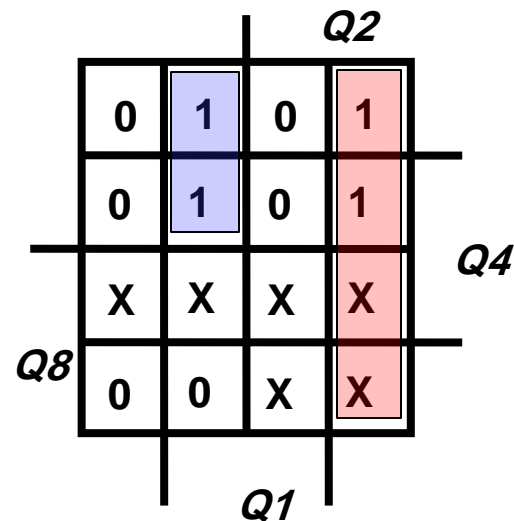
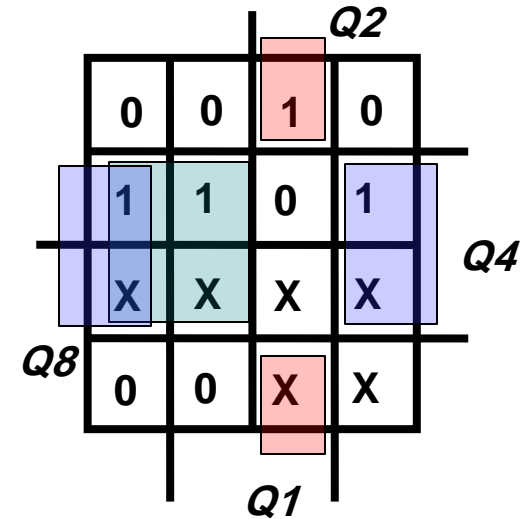
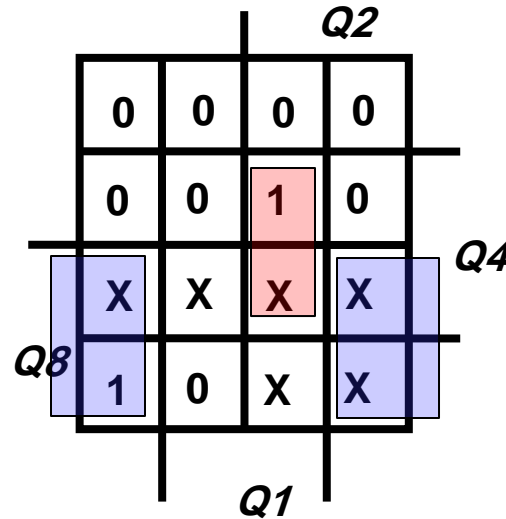

Synchronous BCD (Another Solution)

Present State				Next State			
Q8	Q4	Q2	Q1	Q8	Q4	Q2	Q1
1	0	1	0	1	0	1	1
1	0	1	1	0	1	0	0
1	1	0	0	1	1	0	1
1	1	0	1	0	1	0	0
1	1	1	0	1	1	1	1
1	1	1	1	1	0	0	0

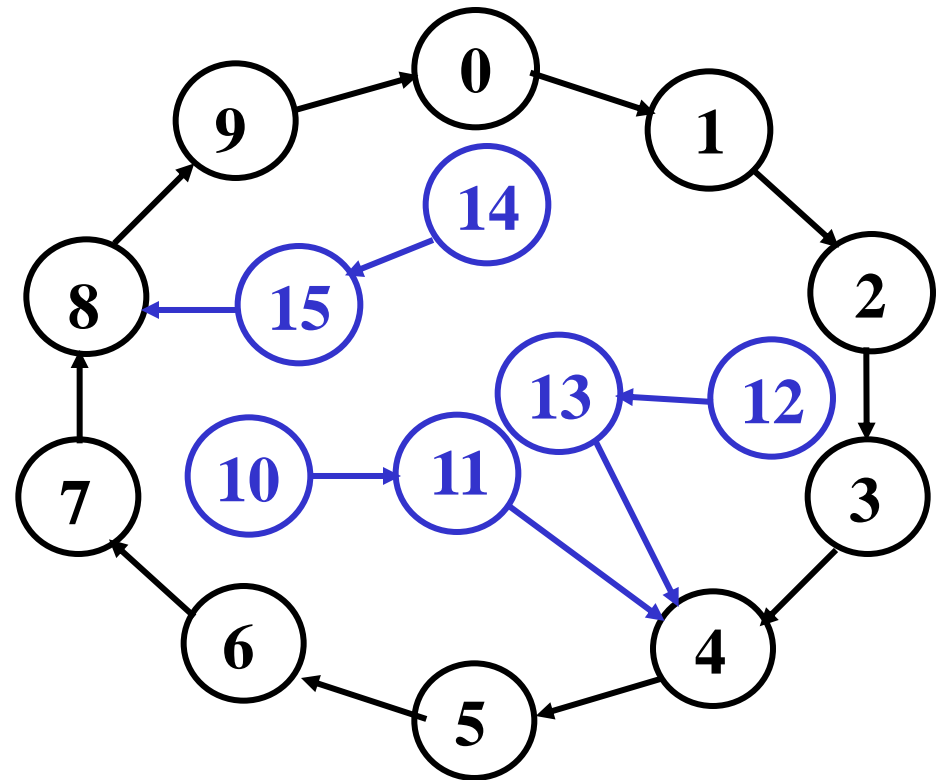

Synchronous BCD (continued)

- For the BCD counter design, if an invalid state is entered, **return to a valid state occurs within two clock cycles**
- **Is this adequate? If not:**
 - Is a signal needed that indicates that an invalid state has been entered? What is the equation for such a signal?
 - Does the design need to be modified to return from an invalid state to a valid state in one clock cycle?
 - Does the design need to be modified to return from a invalid state to a specific state (such as 0)?
- **The action to be taken depends on:**
 - the application of the circuit
 - design group policy

Counting Modulo N

- **The following techniques use an n -bit binary counter with asynchronous or synchronous clear and/or parallel load:**
 - **Detect a *terminal count* of N in a Modulo-N count sequence to asynchronously Clear the count to 0 or asynchronously Load in value 0 (These lead to counts which are present for only a very short time and can fail to work for some timing conditions!)**
 - **Detect a terminal count of N - 1 in a Modulo-N count sequence to Clear the count synchronously to 0**
 - **Detect a terminal count of N - 1 in a Modulo-N count sequence to synchronously Load in value 0**
 - **Detect a terminal count and use Load to preset a count of the terminal count value minus (N - 1)**
- **Alternatively, custom design a modulo N counter as done for BCD**

Counting Modulo 7: Detect 7 and Asynchronously Clear

- A synchronous 4-bit binary counter with an asynchronous Clear is used to make a Modulo 7 counter.
- Use the Clear feature to detect the count 7 and clear the count to 0. This gives a count of 0, 1, 2, 3, 4, 5, 6, **7(short)0**, 1, 2, 3, 4, 5, 6, **7(short)0**, etc.
- **DON'T DO THIS!** Existence of state 7 may not be long enough to reliably reset all flip-flops to 0. Referred to as a “suicide” counter! (Count “7” is “killed,” but the designer’s job may be dead as well!)

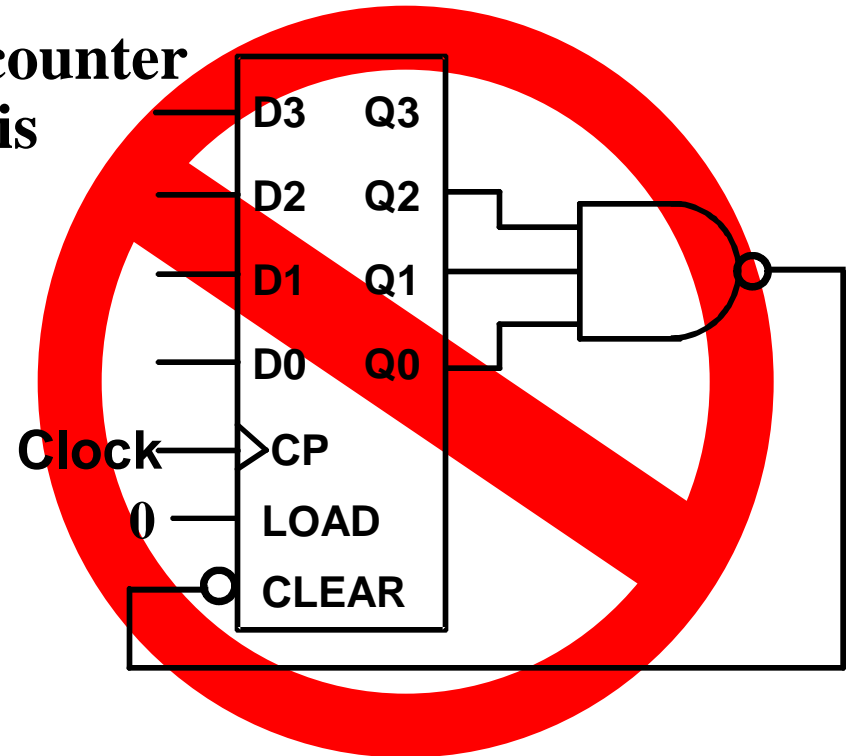

Counting Modulo 7: Synchronously Load on Terminal Count of 6

- A synchronous 4-bit binary counter with a synchronous load and an asynchronous clear is used to make a **Modulo 7 counter**
- Use the Load feature to detect the count "6" and load in "zero". This gives a count of **0, 1, 2, 3, 4, 5, 6, 0, 1, 2, 3, 4, 5, 6, 0, ...**
- Using don't cares for states above 0110, detection of 6 can be done with **Load = Q4 Q2**

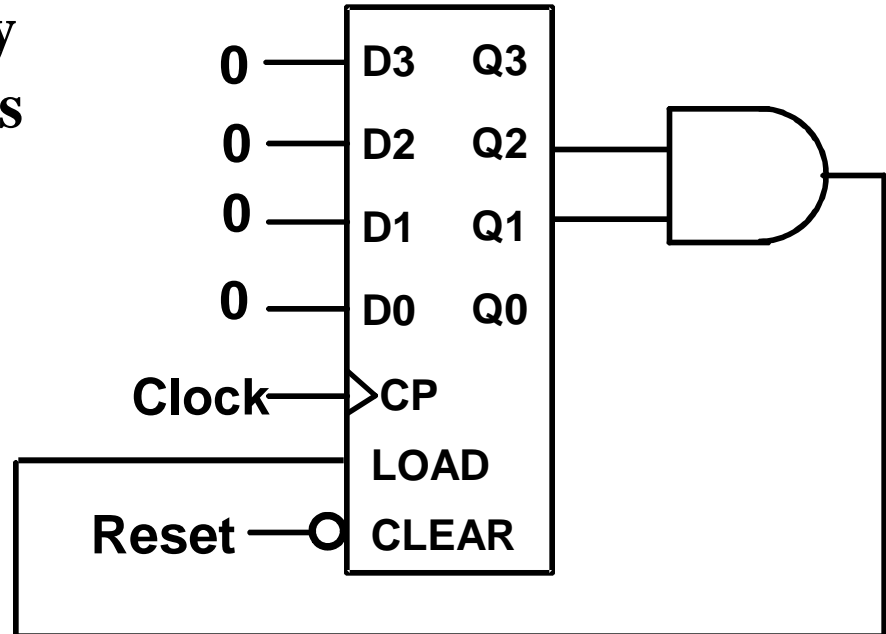

Counting Modulo 7: Synchronously Load on Terminal Count of 6

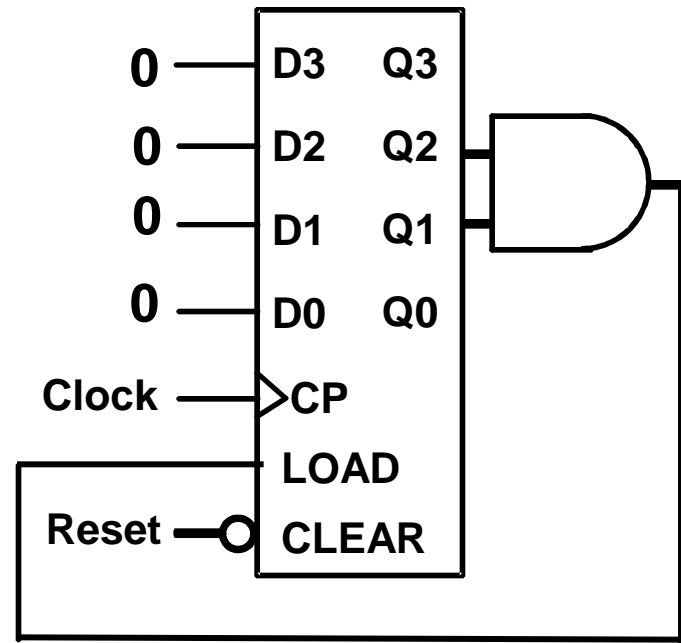
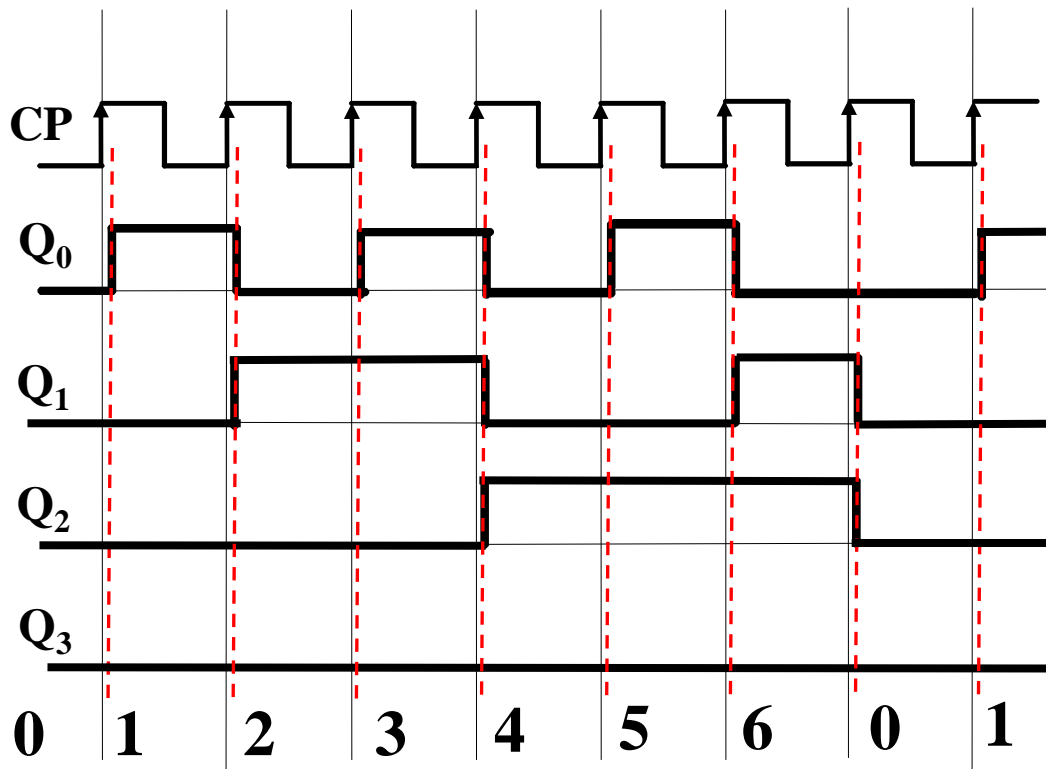

Counting Modulo 9: Synchronously Load on Terminal Count of 8

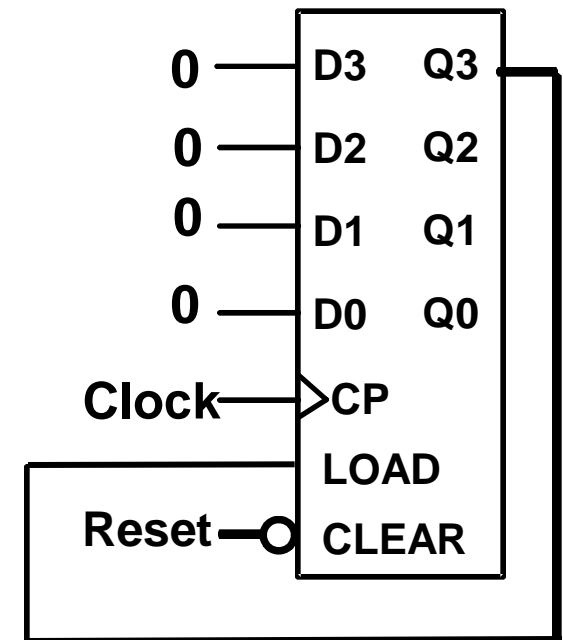
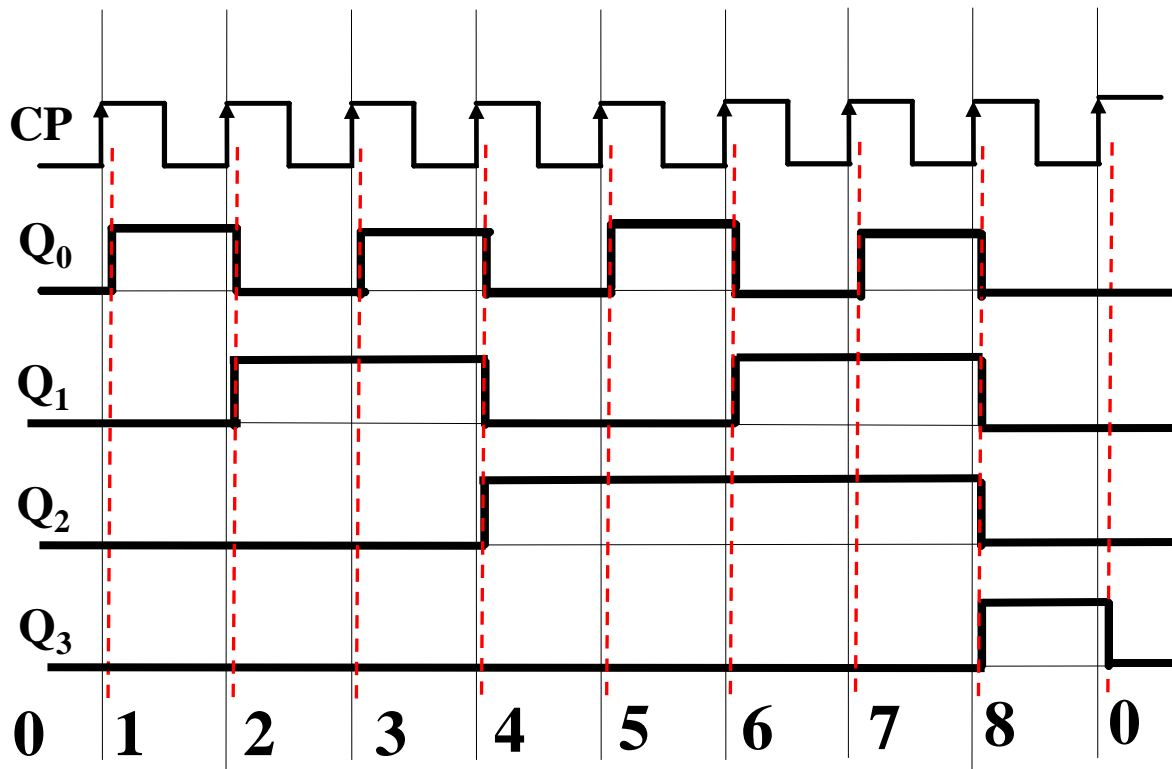

Counting Modulo 6: Synchronously Preset 9 on Reset and Load 9 on Terminal Count 14

- A synchronous, 4-bit binary counter with a synchronous Load is to be used to make a Modulo 6 counter.
- Use the Load feature to preset the count to 9 on Reset and detection of count 14.

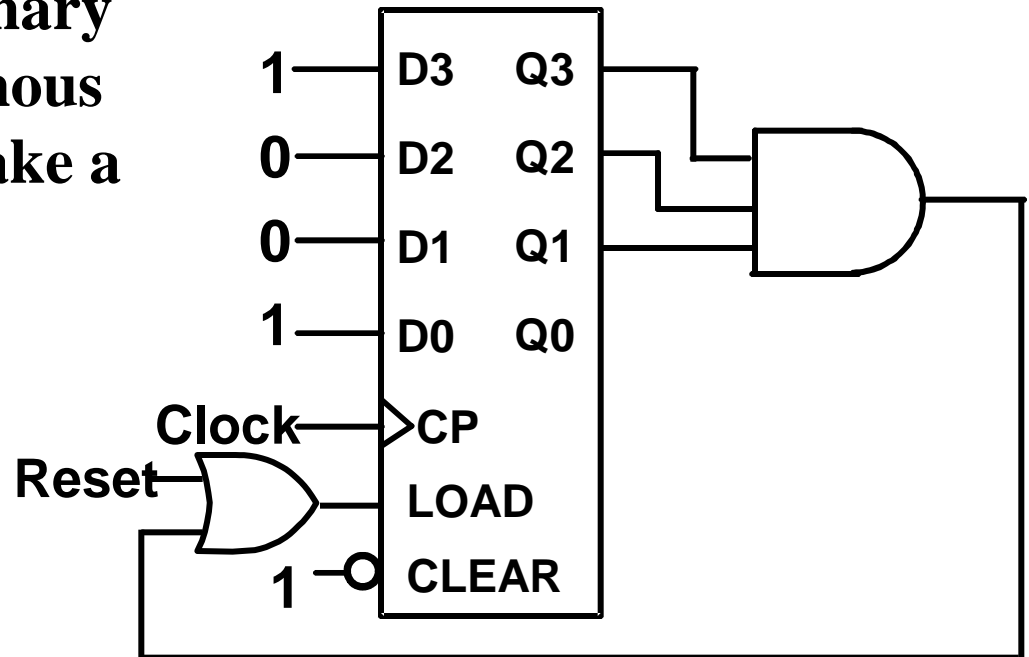

- This gives a count of 9, 10, 11, 12, 13, 14, 9, 10, 11, 12, 13, 14, 9, ...
- If the terminal count is 15 detection is usually built in as Carry Out (CO)

Register Cell Design

- Assume that a register consists of identical cells
- Then register design can be approached as follows:
 - Design representative cell for the register
 - Connect copies of the cell together to form the register
 - Applying appropriate “boundary conditions” to cells that need to be different and contract if appropriate
- Register cell design is the first step of the above process

Register Cell Specifications

- A register
- Data inputs to the register
- Control input combinations to the register
 - **Example 1: Not encoded**
 - Control inputs: **Load, Shift, Add**
 - At most, one of Load, Shift, Add is 1 for any clock cycle
(0,0,0), (1,0,0), (0,1,0), (0,0,1)
 - **Example 2: Encoded**
 - Control inputs: **S1, S0**
 - All possible binary combinations on S1, S0
(0,0), (0,1), (1,0), (1,1)

Register Cell Specifications

- A set of register functions (typically specified as register transfers)

- **Example:**

Load: $A \leftarrow B$

Shift: $A \leftarrow sr B$

Add: $A \leftarrow A + B$

- A hold state specification

- **Example:**

- **Control inputs: Load, Shift, Add**
- **If all control inputs are 0, hold the current register state**

Example 1: Register Cell Design

- **Register A (m-bits) Specification:**
 - **Data input: B**
 - **Control inputs (CX, CY)**
 - **Control input combinations (0,0), (0,1) (1,0)**
 - **Register transfers:**
 - **$CX: A \leftarrow B \vee A$**
 - **$CY :A \leftarrow B \oplus A$**
 - **Hold state: (0,0)**

Example 1: Register Cell Design (continued)

- Load Control

$$\text{Load} = \text{CX} + \text{CY}$$

- All control combinations appear as if encoded (0,0), (0,1), (1,0).

$$S = \text{CX}$$

$$A_i \leftarrow B_i \oplus A_i$$

$$A_i \leftarrow B_i \vee A_i$$

$$\text{CY} = 1$$

$$\text{CX} = 1$$

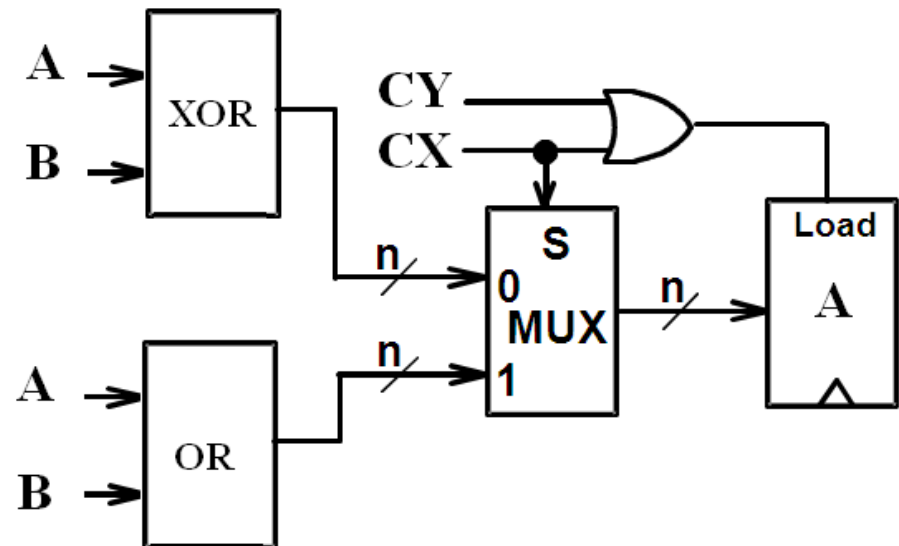

Sequential Circuit Design Approach

- **Find a state diagram or state table**
 - **Note that there are only two states with the state assignment equal to the register cell output value**
- **Use the design procedure in Chapter 5 to complete the cell design**
- **For optimization:**
 - **Use K-maps for up to 4 to 6 variables**
 - **Otherwise, use computer-aided or manual optimization**

Example 1 Again

■ State Table:

	Hold	$A_i \vee B_i$		$A_i \oplus B_i$	
	$CX = 0$	$CX = 1$	$CX = 1$	$CY = 1$	$CY = 1$
A_i	$CY = 0$	$B_i = 0$	$B_i = 1$	$B_i = 0$	$B_i = 1$
0	0	0	1	0	1
1	1	1	1	1	0

- Four variables give a total of 16 state table entries
- By using:
 - Combinations of variable names and values
 - Don't care conditions (for $CX = CY = 1$)

only 8 entries are required to represent the 16 entries

Example 1 Again (continued)

- **K-map - Use variable ordering CX, CY, A_i B_i and assume a D flip-flop**

CX	CY	A _i	B _i	D _i	Description
0	0	0	0	0	HOLD
0	0	0	1	0	
0	0	1	0	1	
0	0	1	1	1	
0	1	0	0	0	CY: A ← B ⊕ A
0	1	0	1	1	
0	1	1	0	1	
0	1	1	1	0	
1	0	0	0	0	CX: A ← B ∨ A
1	0	0	1	1	
1	0	1	0	1	
1	0	1	1	1	
1	1	0	0	X	No Action
1	1	0	1	X	
1	1	1	0	X	
1	1	1	1	X	

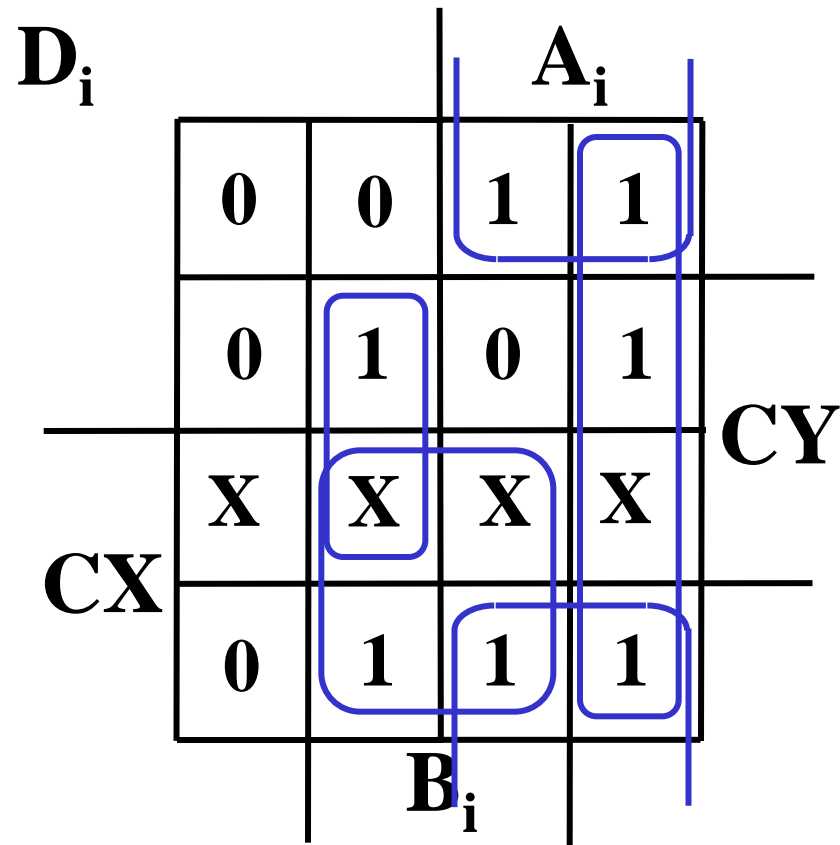

Example 1 Again (continued)

- The resulting SOP equation:

$$D_i = CX B_i + CY \bar{A}_i B_i + A_i \bar{B}_i + \bar{C}\bar{Y} A_i$$

- Using factoring and DeMorgan's law:

$$D_i = CX B_i + \bar{A}_i (CY B_i) + A_i (\bar{C}\bar{Y} B_i)$$

$$D_i = CX B_i + A_i \oplus (CY B_i)$$

The gate input cost per cell = 2 + 8 + 2 + 2 = 14

- The gate input cost per cell for the previous version is:

Per cell: 19

Shared decoder logic: 8

- Cost gain by sequential design > 5 per cell
- Also, no Enable on the flip-flop makes it cost less

Terms of Use

- **All (or portions) of this material © 2008 by Pearson Education, Inc.**
- **Permission is given to incorporate this material or adaptations thereof into classroom presentations and handouts to instructors in courses adopting the latest edition of Logic and Computer Design Fundamentals as the course textbook.**
- **These materials or adaptations thereof are not to be sold or otherwise offered for consideration.**
- **This Terms of Use slide or page is to be included within the original materials or any adaptations thereof.**