

William Stallings

Data and Computer

Communications

Chapter 8

Multiplexing

Multiplexing

- ⌘ multiple channels on 1 physical line
- ⌘ common on long-haul, high capacity, links
- ⌘ have **FDM**, **TDM**, **STDM** alternatives



Frequency Division Multiplexing

- ⌘ Possible with **large bandwidth**
- ⌘ **Multiple signals carried simultaneously**
- ⌘ **Each signal modulated onto different carrier frequency**
- ⌘ Carrier frequencies must be sufficiently separated
- ⌘ Bandwidths should **not overlap**

Frequency Division Multiplexing

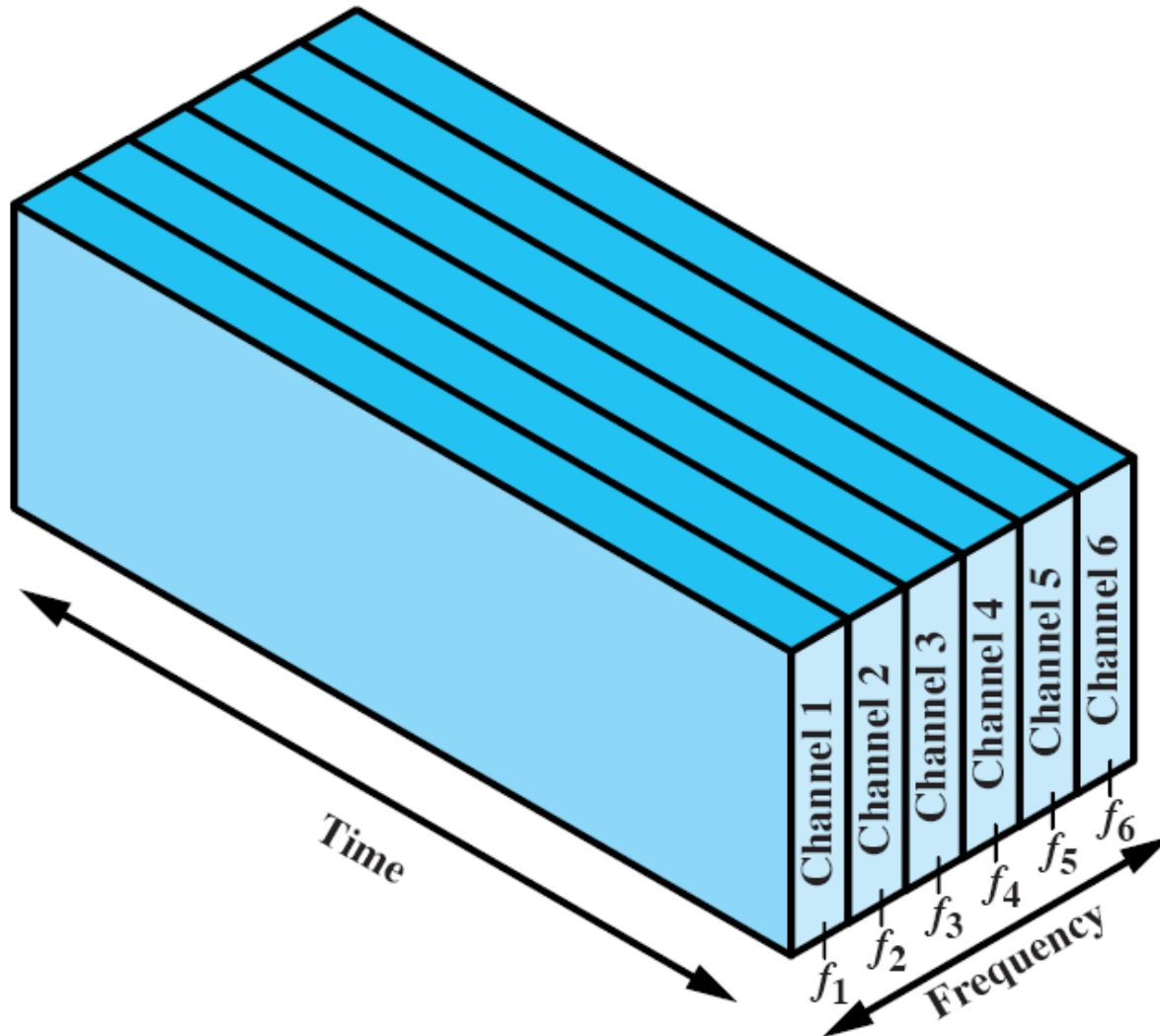

Frequency Division Multiplexing

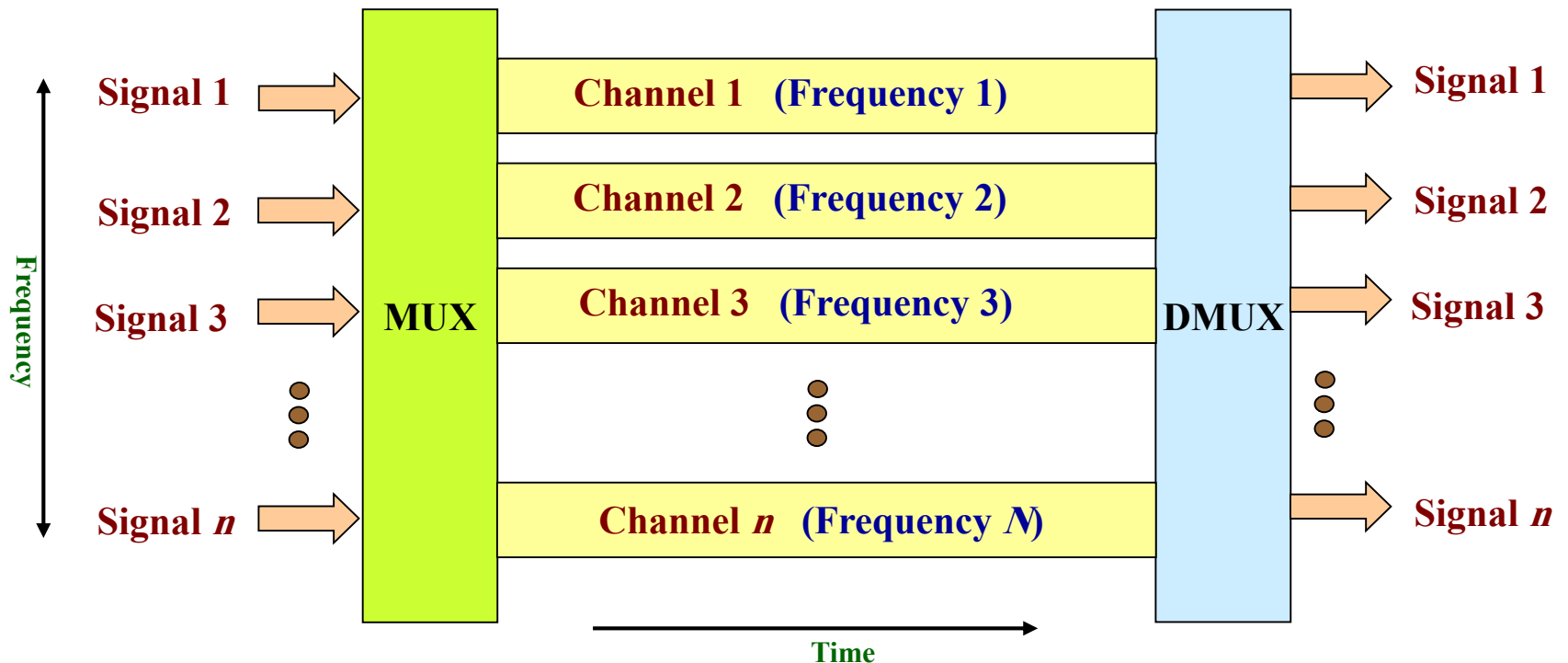

Frequency Division Multiplexing

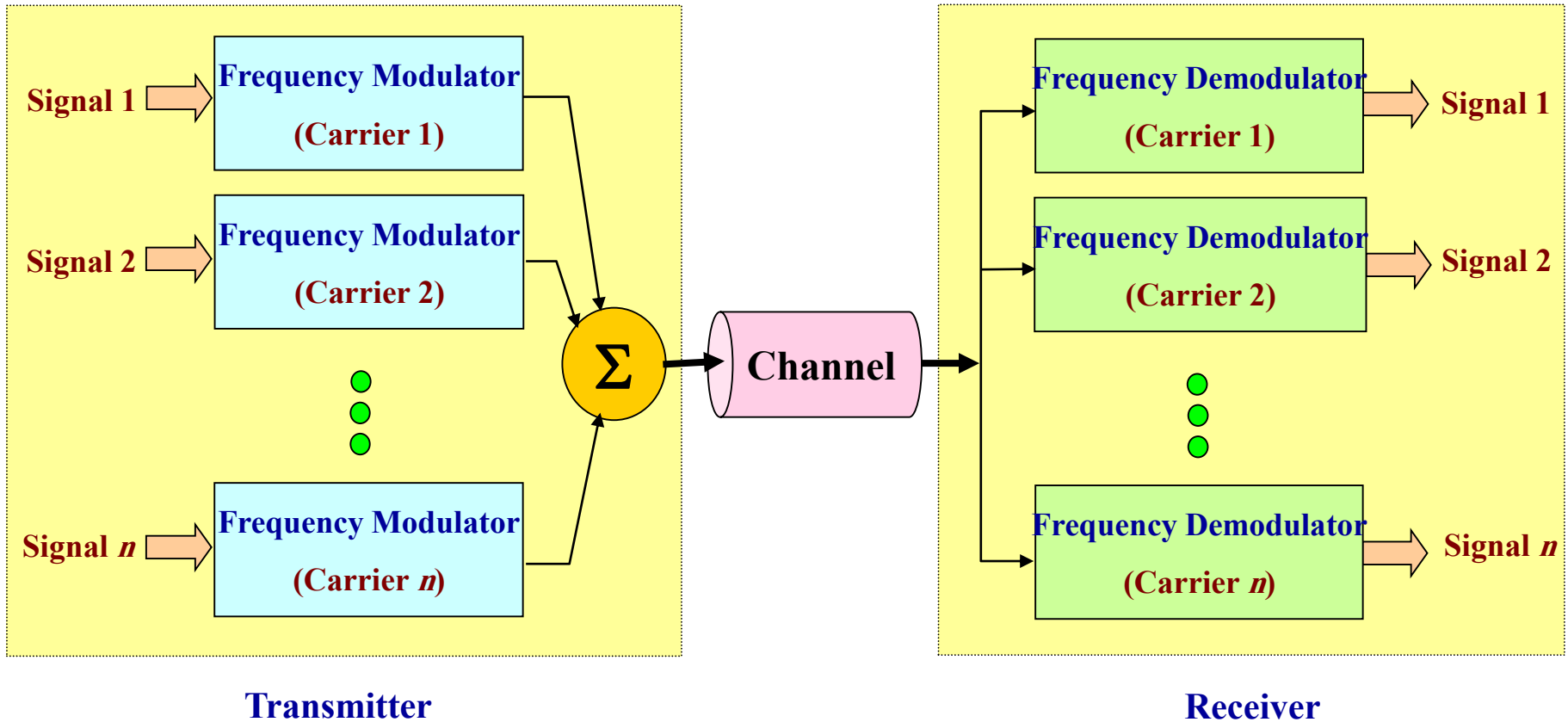

Frequency Division Multiplexing

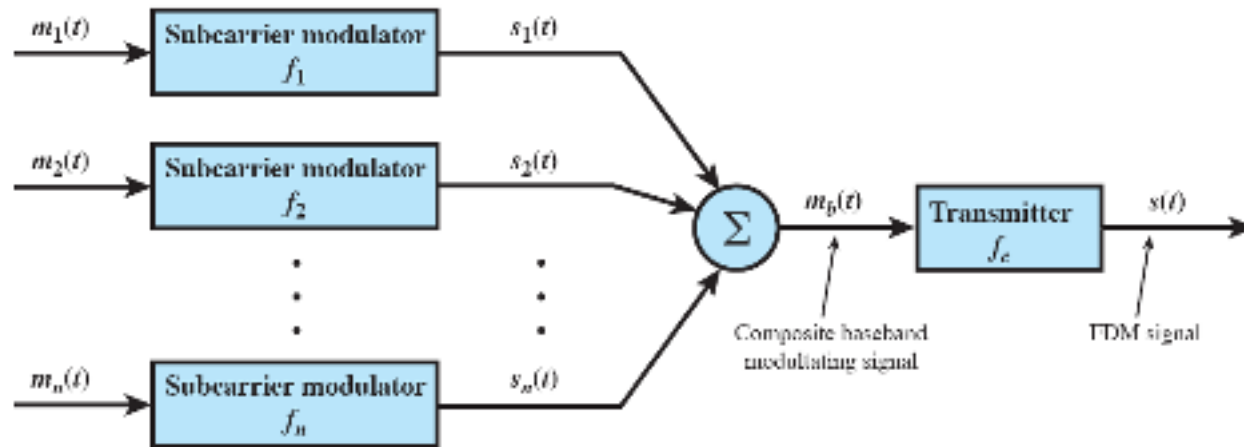

(a) Transmitter

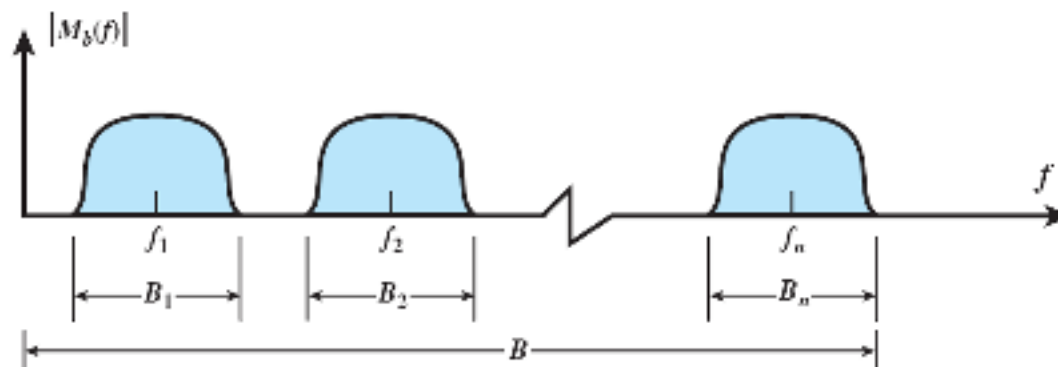

(b) Spectrum of composite baseband modulating signal

Frequency Division Multiplexing

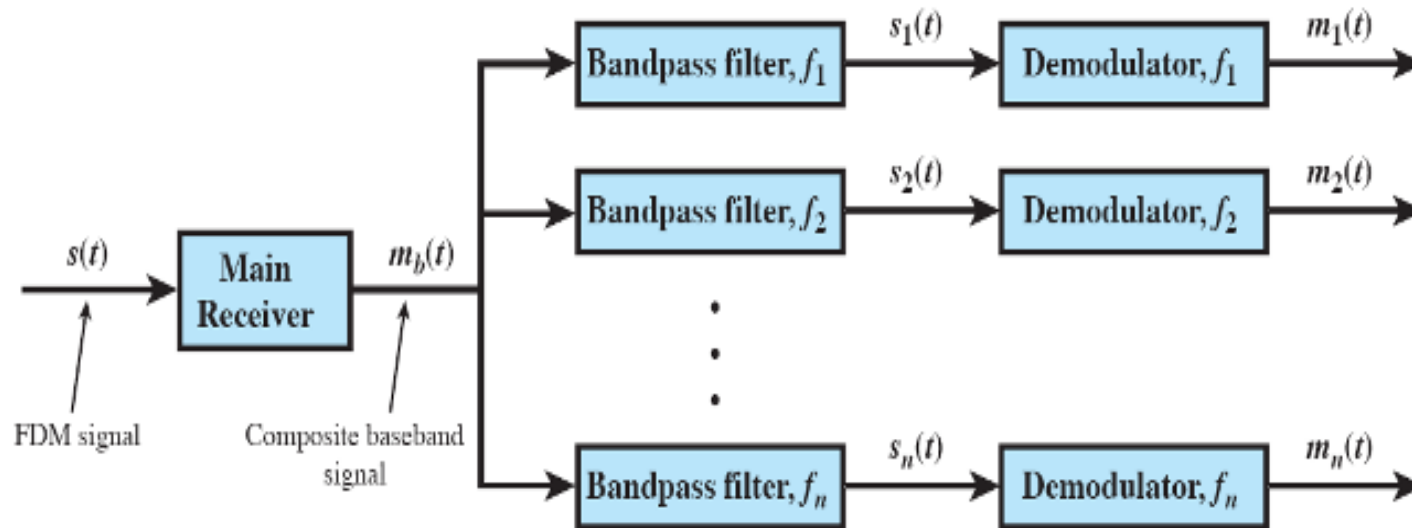

(c) Receiver

Frequency Division Multiplexing: Voice Signal

- ⌘ Bandwidth of **voice signal (300-3400 Hz)**
- ⌘ **Generally taken as 4 kHz**
- ⌘ Using AM with carrier frequency **64 kHz**
- ⌘ Spectrum of modulated signal is 8 kHz
 - ⊞ **60 kHz – 68 kHz**
- ⌘ To make efficient use of bandwidth
 - ⊞ **transmit only lower sideband**

Frequency Division Multiplexing: Voice Signal

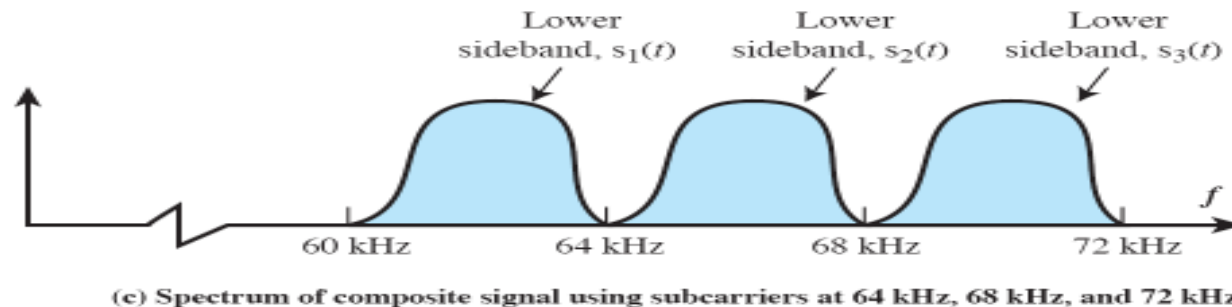
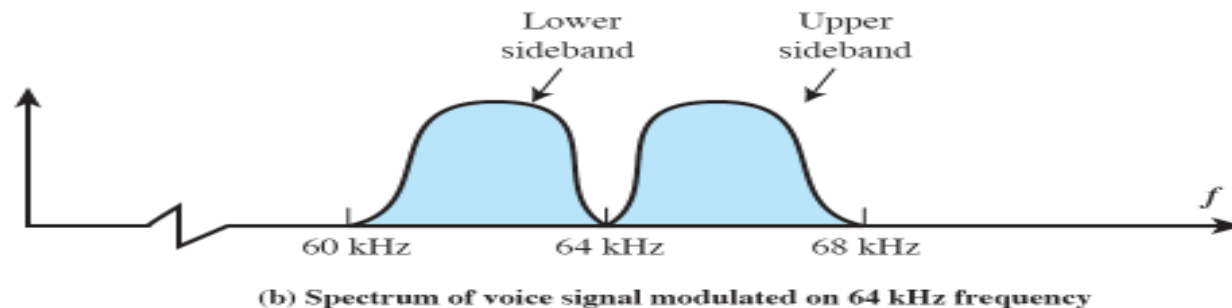
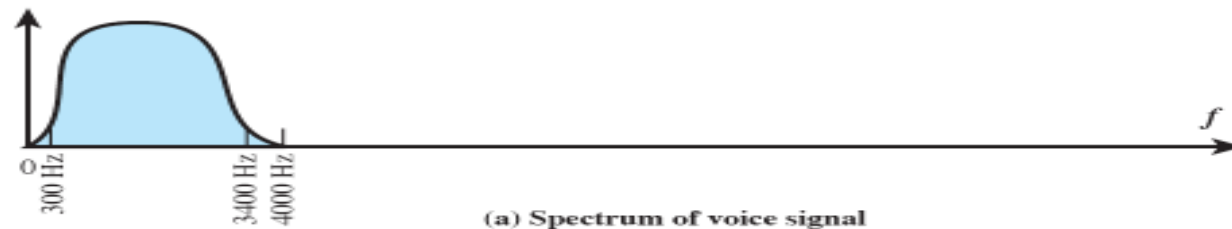

Frequency Division Multiplexing

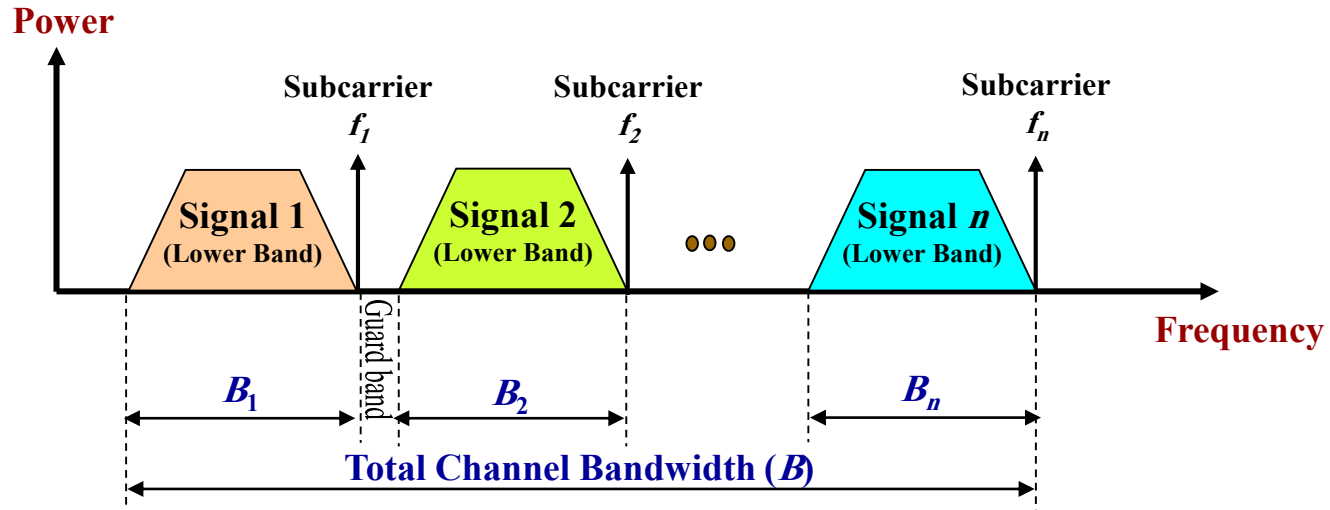

- ☒ B = total channel bandwidth where $B > \sum_{i=1}^n B_i$
- ☒ B_i = bandwidth of a signal

FDM Problems

⌘ Crosstalk

- ⊞ spectra of adjacent component signals overlap
 - ⊗ guard band should be added
 - ⊗ e.g. voice 4 kHz instead of 3400 Hz

⌘ Intermodulation noise

- ⊞ nonlinear effects of **amplifiers** on a signal in one channel could produce frequency components of other channels

Analog Carrier Systems

- ⌘ long-distance links use an FDM hierarchy
- ⌘ AT&T (USA) and ITU-T (International) variants
- ⌘ **Group**
 - ⊞ 12 voice channels (4kHz each) = 48kHz
 - ⊞ in range 60kHz to 108kHz
- ⌘ **Supergroup**
 - ⊞ FDM of 5 group signals supports 60 channels
 - ⊞ on carriers between 420kHz and 612 kHz
- ⌘ **Mastergroup**
 - ⊞ FDM of 10 supergroups supports 600 channels
- ⌘ so original signal can be modulated many times

Frequency Division Multiplexing

North America and International carrier standards:

Number of Voice Channels	Bandwidth	Spectrum	AT&T	CCIT
12	48 KHz	60-108 KHz	Group	Group
60	240 KHz	312-552 KHz	Supergroup	Supergroup
300	1.232 MHz	812-2044 KHz		Mastergroup
600	2.52 MHz	564-3084 KHz	Mastergroup	
900	3.872 MHz	8.516-12.388 MHz		Supermaster Group
$N \times 600$			Mastergroup Multiplex	
3,600	16.984 MHz	0.564-17.548 MHz	Jumpogroup	
10,800	57.442 MHz	3.124-60.566 MHz	Jumpogroup Multiplex	

Frequency Division Multiplexing

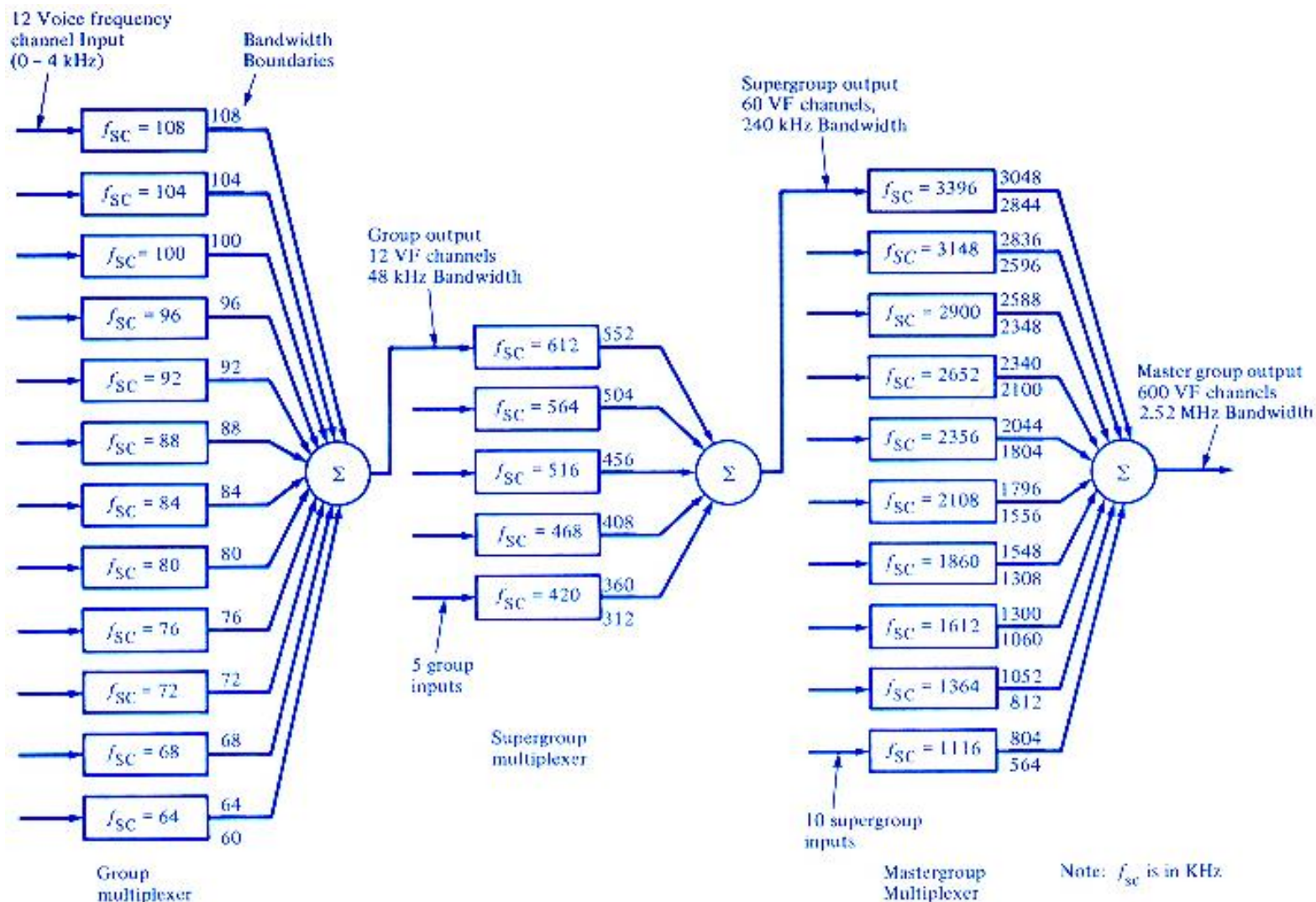

Frequency Division Multiplexing

Broadcast Television Channel Frequency Allocation

Channel Number	Band (MHz)	Channel Number	Band (MHz)	Channel Number	Band (MHz)
2	54–60	25	536–542	48	674–680
3	60–66	26	542–548	49	680–686
4	66–72	27	548–554	50	686–692
5	76–82	28	554–560	51	692–698
6	82–88	29	560–566	52	698–704
7	174–180	30	566–572	53	704–710
8	180–186	31	572–578	54	710–716
9	186–192	32	578–584	55	716–722
10	192–198	33	584–590	56	722–728
11	198–204	34	590–596	57	728–734
12	204–210	35	596–602	58	734–740
13	210–216	36	602–608	59	740–746
14	470–476	37	608–614	60	746–752
15	476–482	38	614–620	61	752–758
16	482–488	39	620–626	62	758–764
17	488–494	40	626–632	63	764–770
18	494–500	41	632–638	64	770–776
19	500–506	42	638–644	65	776–782
20	506–512	43	644–650	66	782–788
21	512–518	44	650–656	67	788–794
22	518–524	45	656–662	68	794–800
23	524–530	46	662–668	69	800–806
24	530–536	47	668–674		

Wavelength Division Multiplexing

⌘ FDM with multiple beams of light at different frequencies are transmitted on the same optical fiber

☑ commercial systems with 160 channels of 10 Gbps

☑ Alcatel has carried 256 channels at 39.8 Gbps each, a total of 10.1 Tbps, over a 100-km

⌘ architecture similar to other FDM systems

☑ **multiplexer** consolidates laser sources (1550nm) for transmission over single fiber

☑ **optical amplifiers** amplify all wavelengths

☑ **demultiplexer** separates channels at the destination

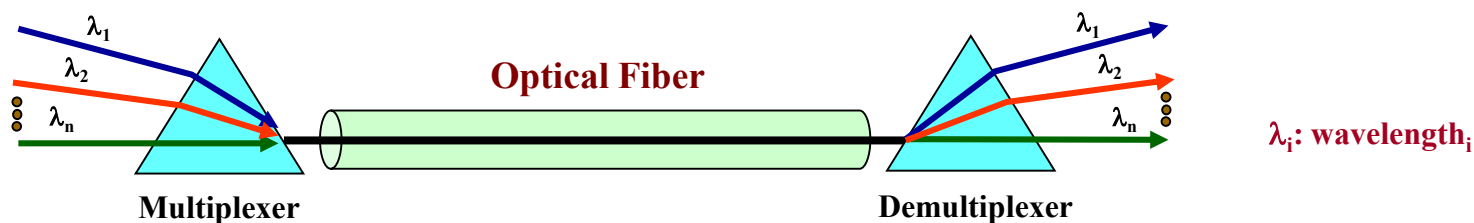



Dense Wavelength Division Multiplexing

- ⌘ Dense wavelength division multiplexing (DWDM) refers originally to optical signals multiplexed within the 1550 nm band so as to utilize the capabilities of **optical amplifiers** which are effective for wavelengths between approximately **1525-1565 nm** (C band), or **1570-1610 nm** (L band)
- ⌘ DWDM combines up to several wavelengths onto a single fiber and uses an **ITU standard** that specifies **100GHz or 200GHz spacing between the wavelengths**, arranged in several bands around 1500-1600nm.
- ⌘ use of more channels, more closely spaced, than ordinary FDM, resulting in the multiplexing equipment being more complex and expensive



Dense Wavelength Division Multiplexing

- ⌘ channel spacing of **200GHz or less** could be considered **dense**
- ⌘ typical system would use **40 channels at 100 GHz spacing** or **80 channels with 50 GHz spacing**
- ⌘ Some technologies are capable of **25 GHz spacing** (sometimes called **ultra dense WDM**)

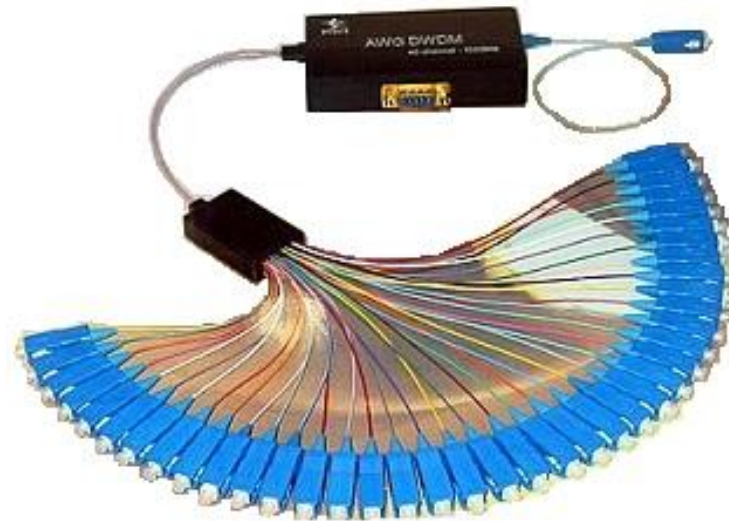

40 channels DWDM



Dense Wavelength Division Multiplexing

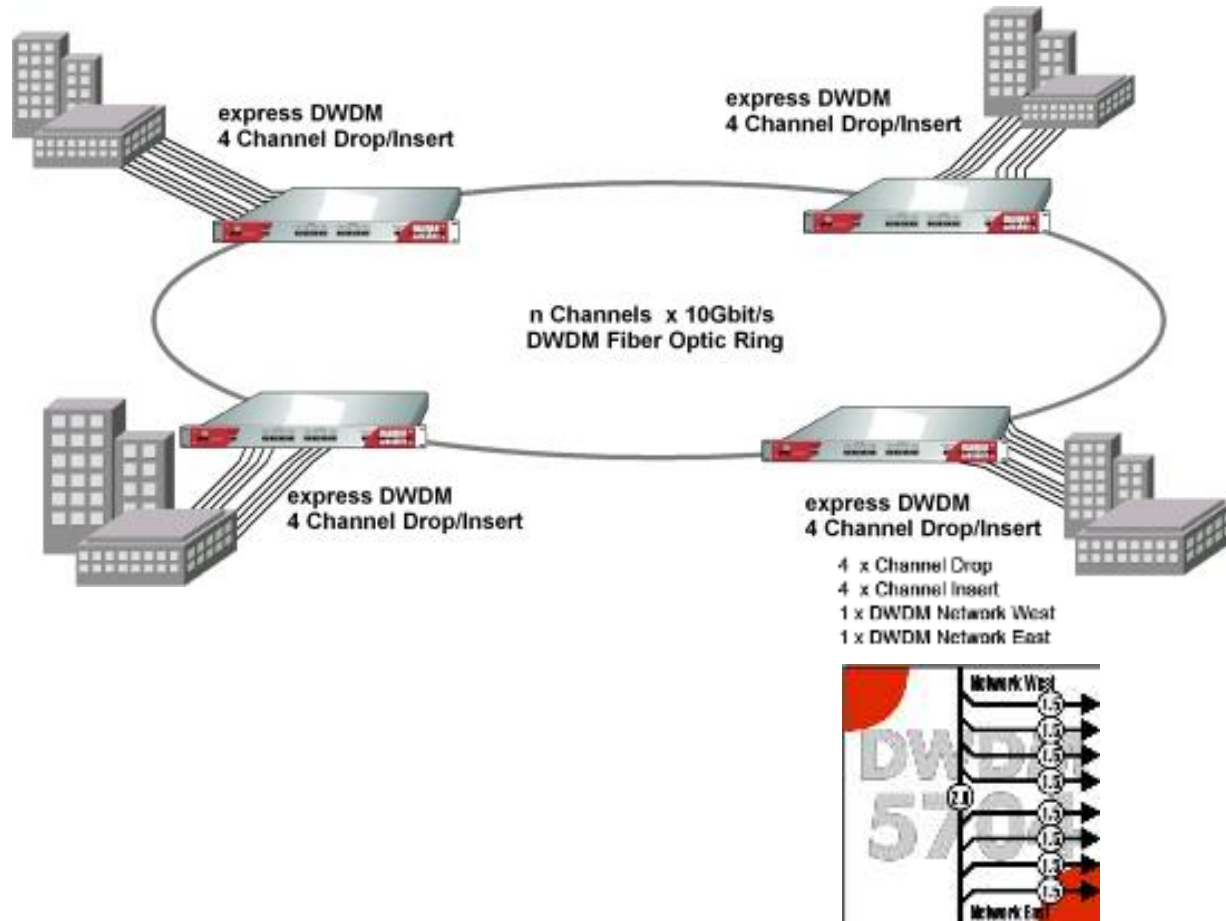

Connecting locations redundantly with a Multiple-10Gbit/s Fiber Optic Ring

Synchronous Time Division Multiplexing

- ⌘ multiple digital signals carried on single path
- ⌘ portions of each signal interleaved in time
- ⌘ **byte Interleaving**, each time slot contains one character of data
- ⌘ time slots **pre-assigned** to sources
 - ⊞ **Synchronous TDM is called synchronous not because synchronous transmission is used, but because the time slots are pre-assigned to sources and fixed.**
- ⌘ slot transmitted even if source has **no data**
- ⌘ may **waste** capacity but simple to implement
- ⌘ different data rates are possible
- ⌘ fast source can be assigned multiple slots
- ⌘ slots dedicated to source called **channel**

Synchronous Time Division Multiplexing

At the transmitter:

- ⌘ data from each source is buffered
- ⌘ buffers scanned sequentially to form a composite digital signal $m_c(t)$
- ⌘ **scanning operation** is sufficiently rapid so that each buffer is emptied before more data can arrive
- ⌘ The data rate of the composite signal $m_c(t)$ must be at least equal the sum of data rates of input signals $m_\lambda(t)$
- ⌘ data organized into frames, each frame contains a cycle of time slots

At the receiver:

- ⌘ the interleaved data are demultiplexed and routed to the appropriate destination buffer.

Synchronous Time Division Multiplexing

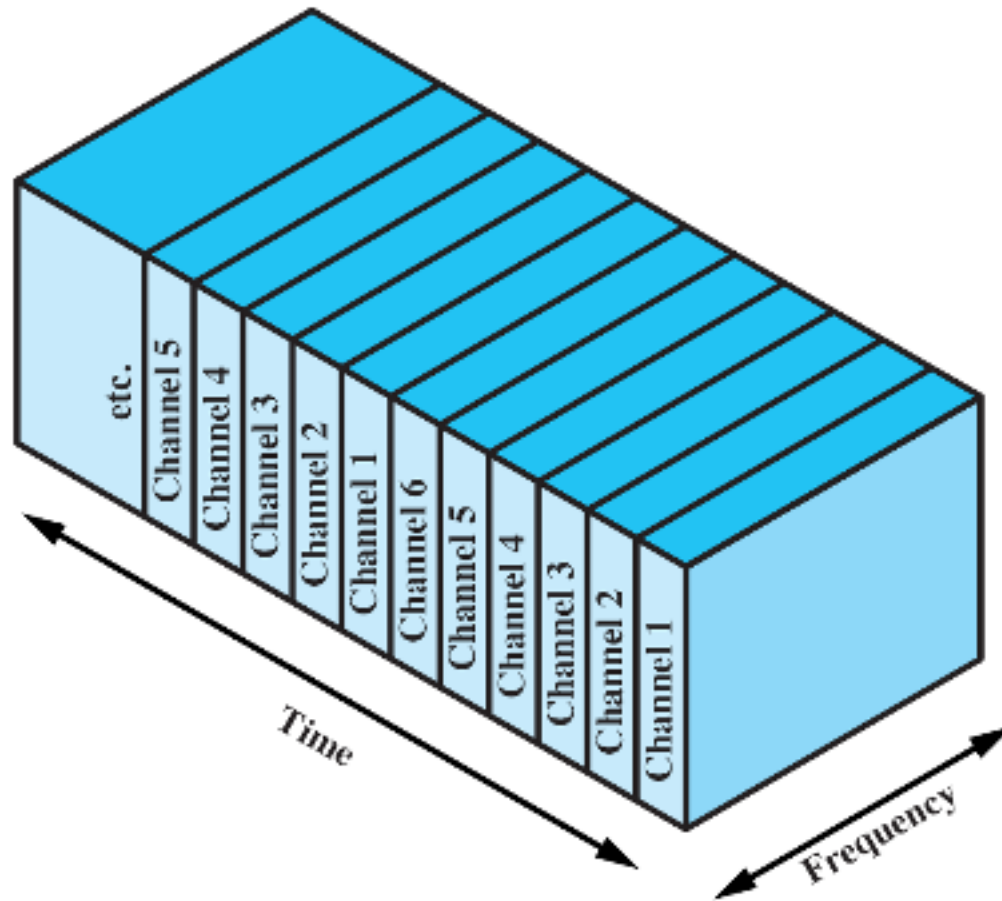

Synchronous Time Division Multiplexing

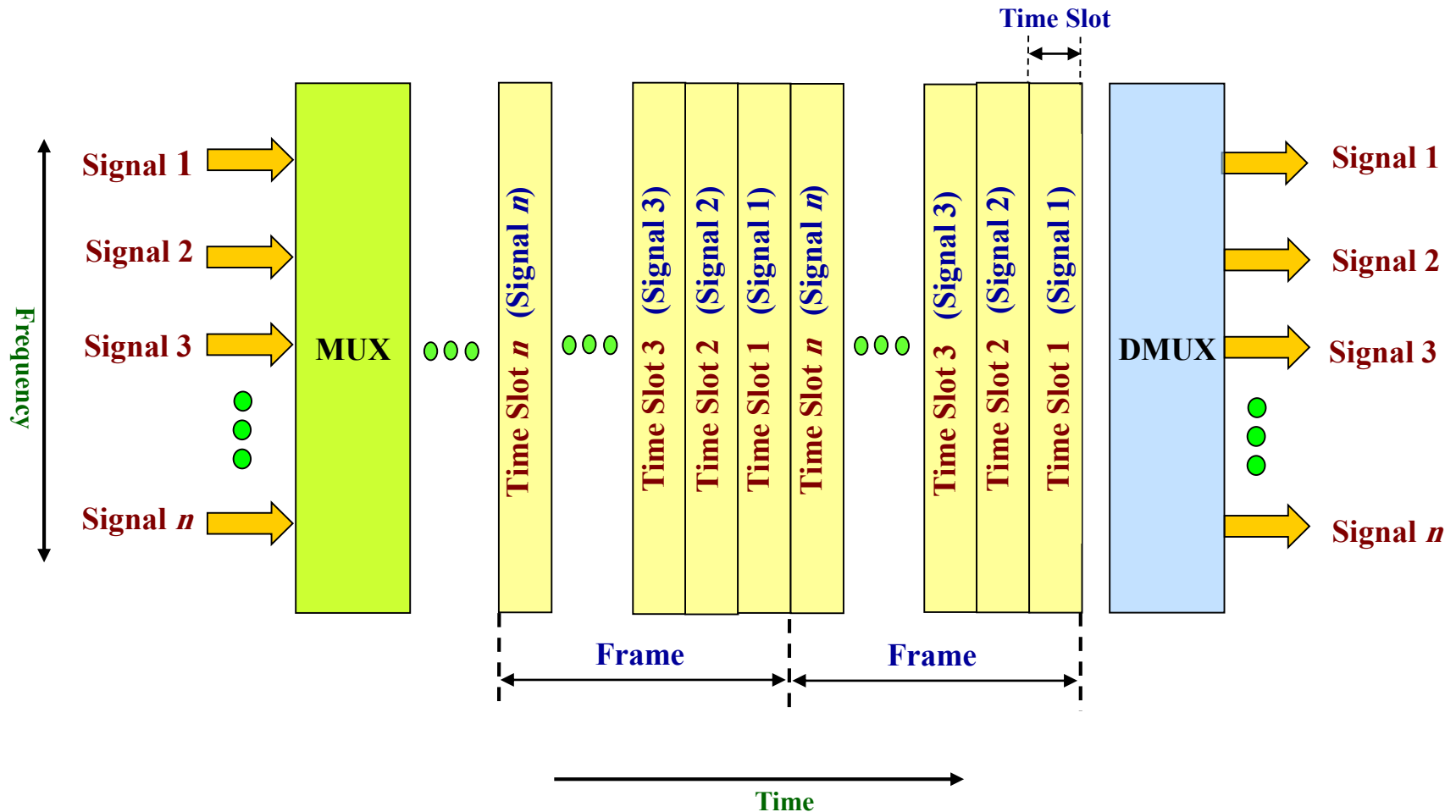

Synchronous Time Division Multiplexing

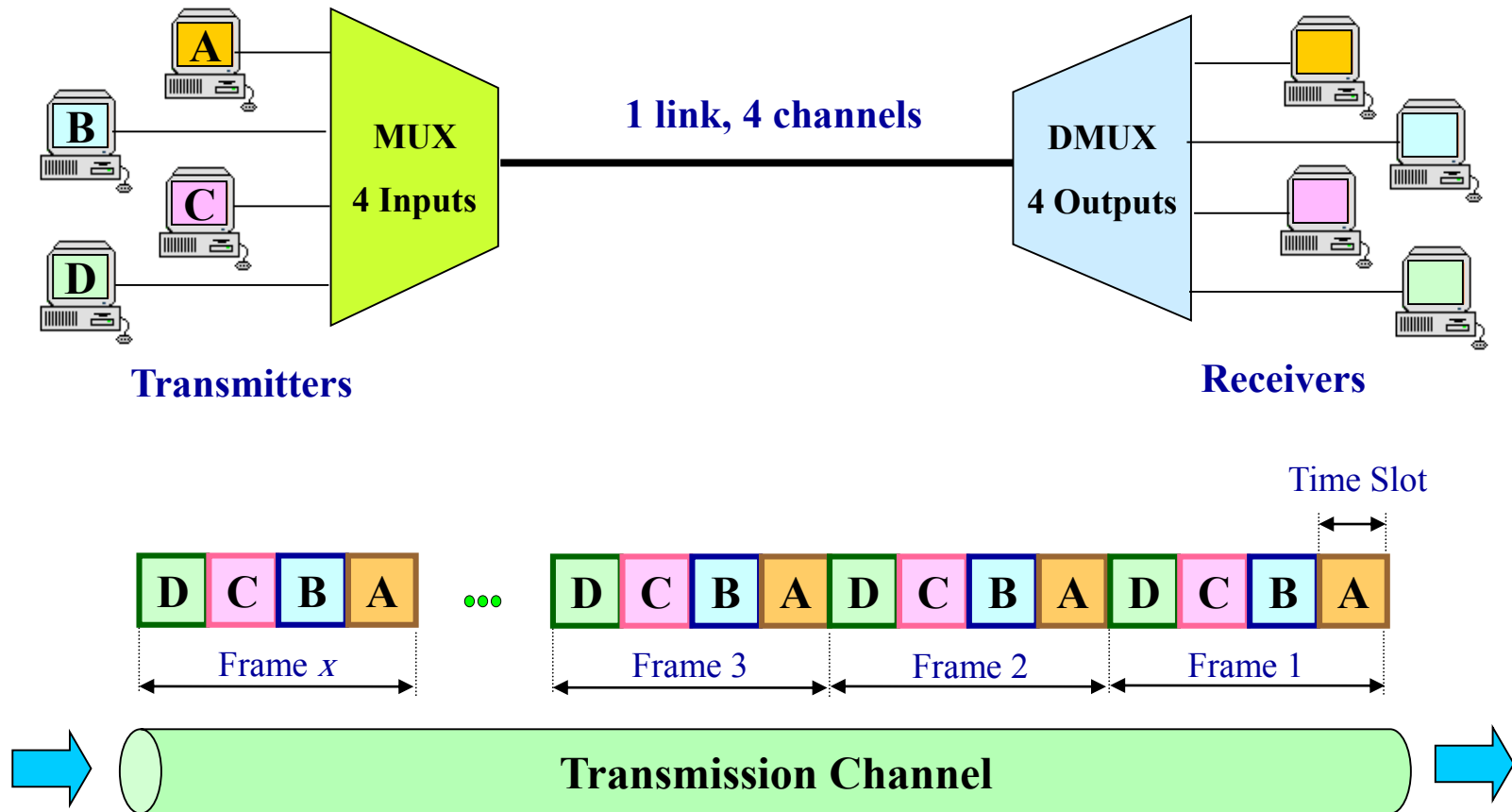

Synchronous Time Division Multiplexing

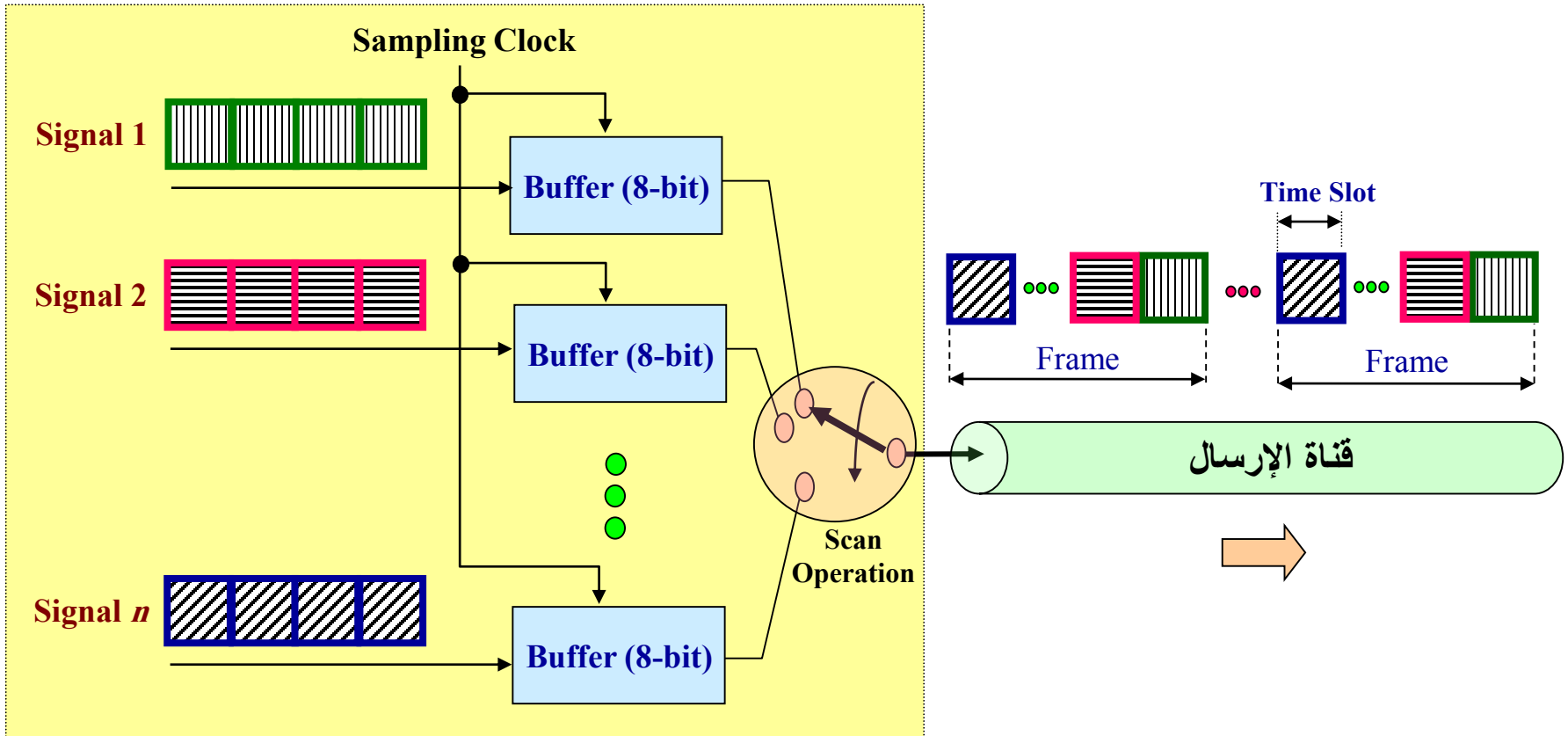

Transmitters

Synchronous Time Division Multiplexing

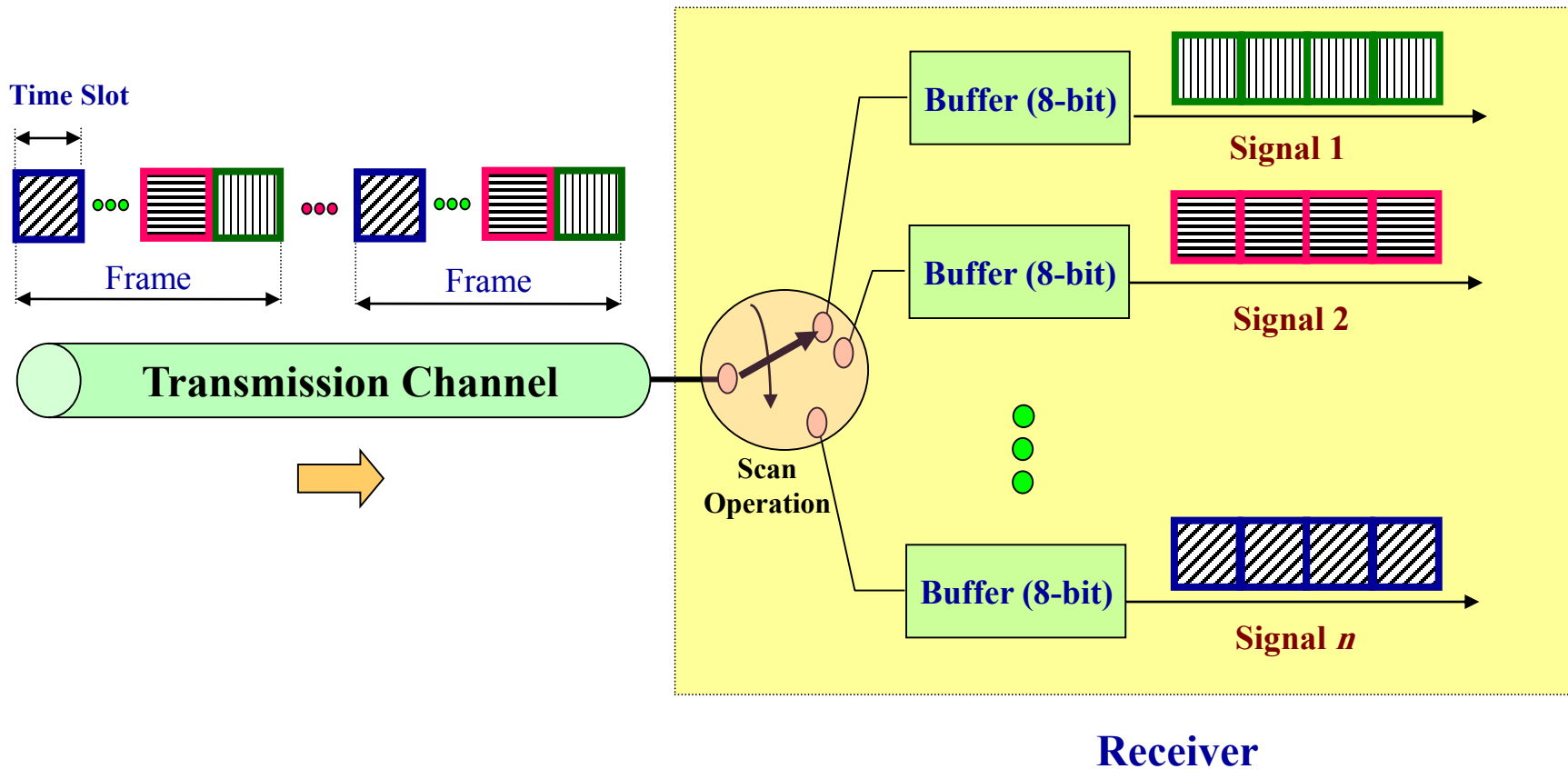

Synchronous Time Division Multiplexing

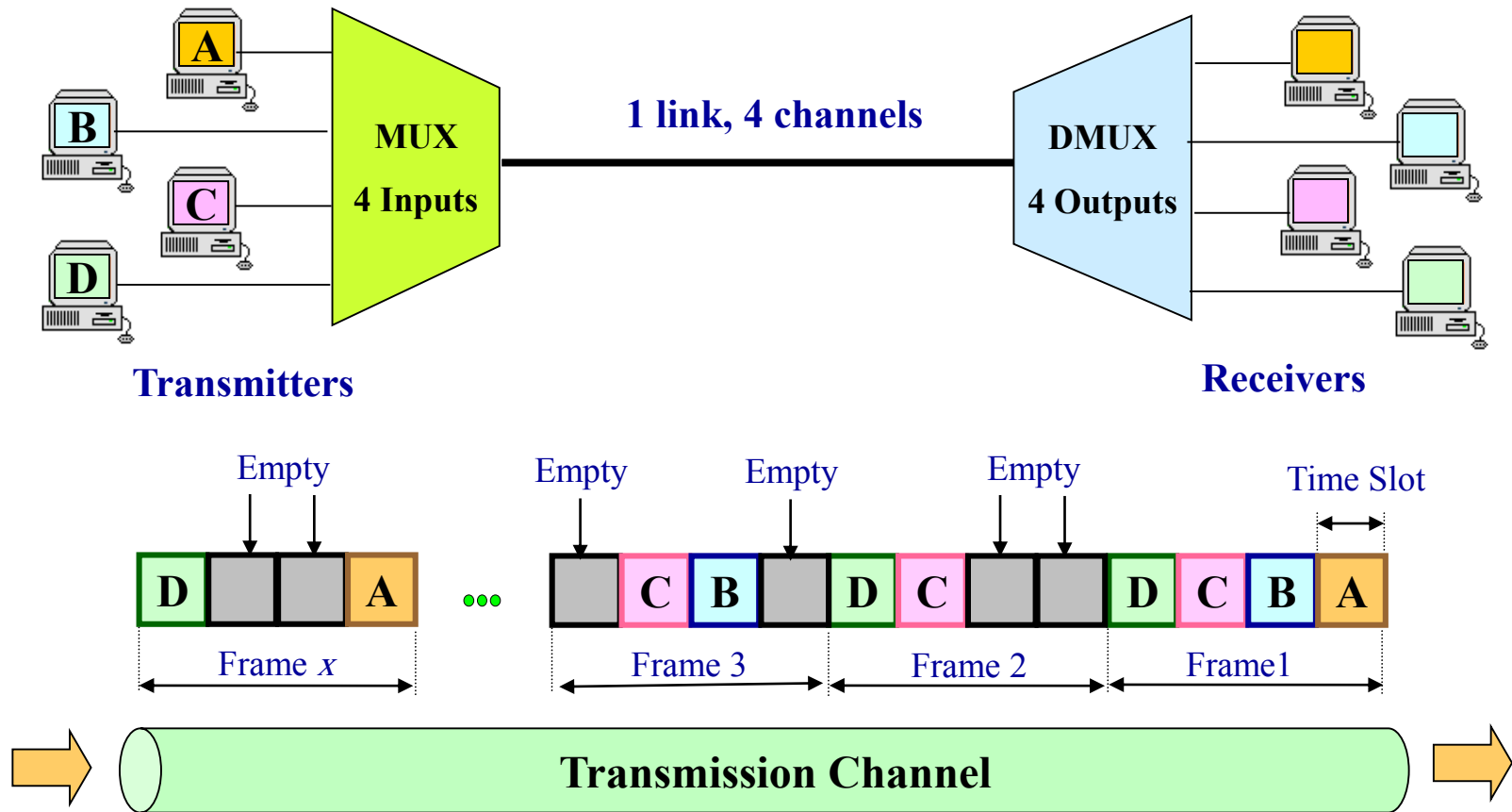

Bursty traffic → Waste of resources

Synchronous Time Division Multiplexing

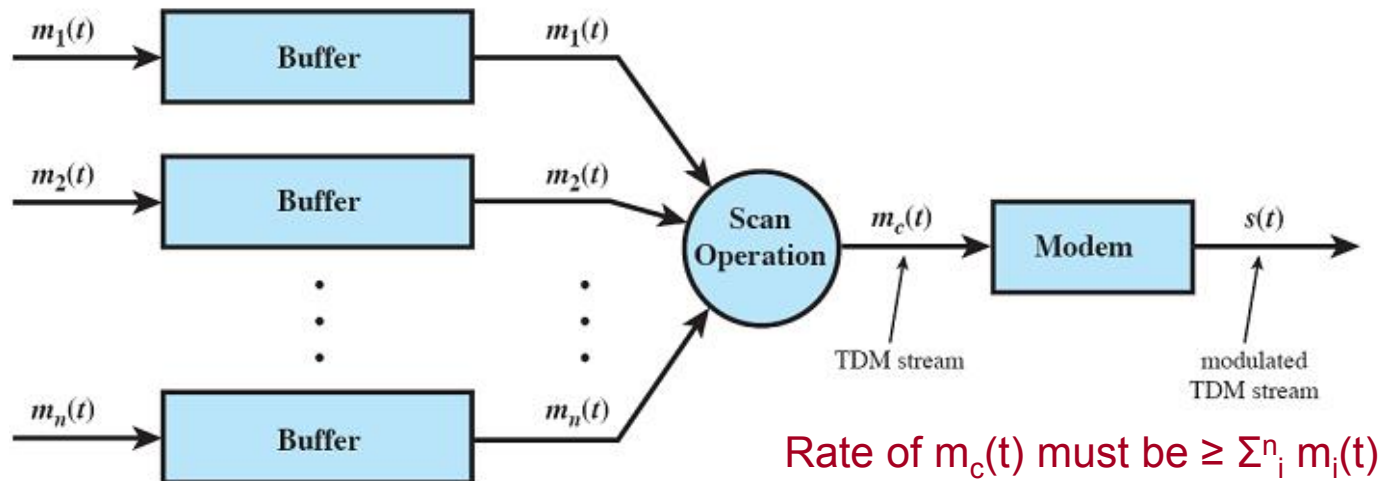

(a) Transmitter

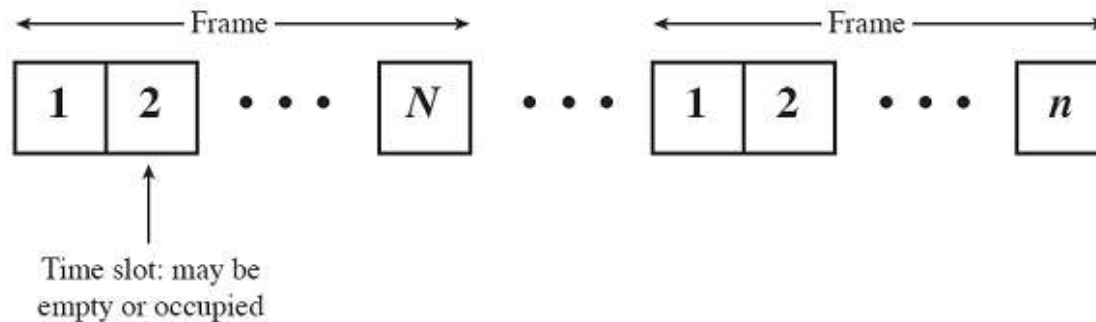

(b) TDM Frames

Time Division Multiplexing

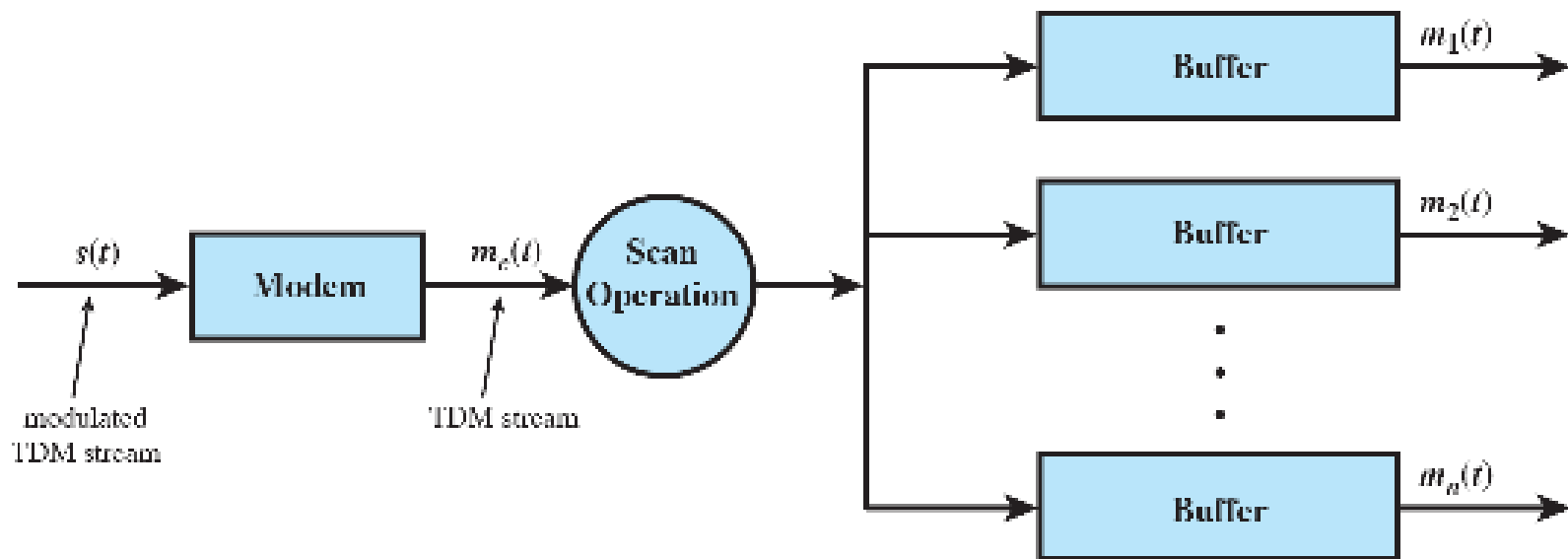

(c) Receiver

TDM Link Control

⌘ no headers and trailers

⌘ **data link control protocols (flow control and error control) not needed**

⌘ flow control

☒ As far as multiplexers and demultiplexers are concerned, flow control is **not needed**.

☒ data rate of multiplexed line is fixed

☒ if one channel is temporarily unable to accept data, the other channels are expecting to receive data at predetermined time

☒ corresponding source must be quenched

☒ the channel will carry empty slots

☒ flow control can be provided on per channel basis

⌘ error control

☒ error control can be provided on per channel basis by using HDLC

Data Link Control on TDM



(a) Configuration

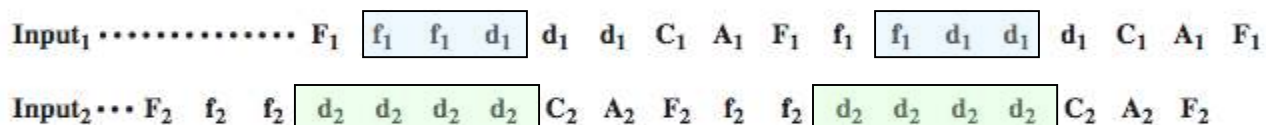

(b) Input data streams

... f₂ F₁ d₂ f₁ d₂ f₁ d₂ d₁ d₂ d₁ C₂ d₁ A₂ C₁ F₂ A₁ f₂ F₁ f₂ f₁ d₂ f₁ d₂ d₁ d₂ d₁ d₂ d₁ C₂ C₁ A₂ A₁ F₂ F₁

(c) Multiplexed data stream

Legend: F = flag field d = one octet of data field
 A = address field f = one octet of FCS field
 C = control field

Framing

⌘ It is important to maintain **framing synchronization** because, if the source and destination are out of step, data on all channels are lost

⌘ added digit framing:

- ⊞ **one control bit** added to each TDM frame

- ⊞ T1 Link

- ⊞ **identifiable bit pattern** used on control channel

- ⊞ e.g., **alternating 01010101**...unlikely on a data channel

- ⊞ E1 Link

Synchronizing Multiple Sources

Pulse Stuffing

- ⌘ Most difficult problem in TDM design
- ⌘ If each source has separate clock
 - ☑ any variation among clocks → **loss of sync**
- ⌘ Input data rates not related by simple rational number
- ⌘ **Pulse stuffing** is a common solution
 - ☑ have outgoing data rate (excluding framing bits) higher than sum of incoming rates
 - ☑ stuff extra dummy bits or pulses into each incoming signal until it matches local clock
 - ☑ stuffed pulses inserted at fixed locations in frame and removed at demultiplexer

Pulse Stuffing - Example

Inputs:

- ⌘ Source 1: Analog, 2 kHz
- ⌘ Source 2: Analog, 4 kHz
- ⌘ Source 3: Analog, 2 kHz
- ⌘ Sources 4-11: Digital, 7200 bps

From source 1
2 kHz, analog

From source 2
4 kHz, analog

From source 3
2 kHz, analog

From source 4
7.2 kbps, digital

From source 5
7.2 kbps, digital

•
•
•

From source 11
7.2 kbps, digital

Pulse Stuffing - Example

For analog sources:

- ☒ Sources 1, 3 sampled at **4000 samples/sec**
- ☒ Source 2 at **8000 samples/sec**
- ☒ PAM samples are then quantized using 4 bits/sample → PCM
- ☒ At scan rate of 4000 times per second, **one** PAM sample (**4 bits**) is taken from sources 1, 3 and **two** PAM samples (**8 bits**) are taken from source 2 per scan
- ☒ These four samples are interleaved and converted to 4-bit PCM samples
- ☒ Total of 16 bits are generated at rate of 4000 times per second → 64 kbps

For digital sources:

- ☒ Pulse stuffing raise each source to a rate of 8 kbps
- ☒ aggregate data rate = 64 kbps
- ⌘ For example, frame can consist of **32 bits**
- ⌘ Each frame containing **16 PCM** bits ($64\text{kbps}/128\text{kps}\times 32$) and **2 bits** ($8\text{kbps}/128\text{kbps}\times 32$) from each of the eight digital sources.

Pulse Stuffing - Example

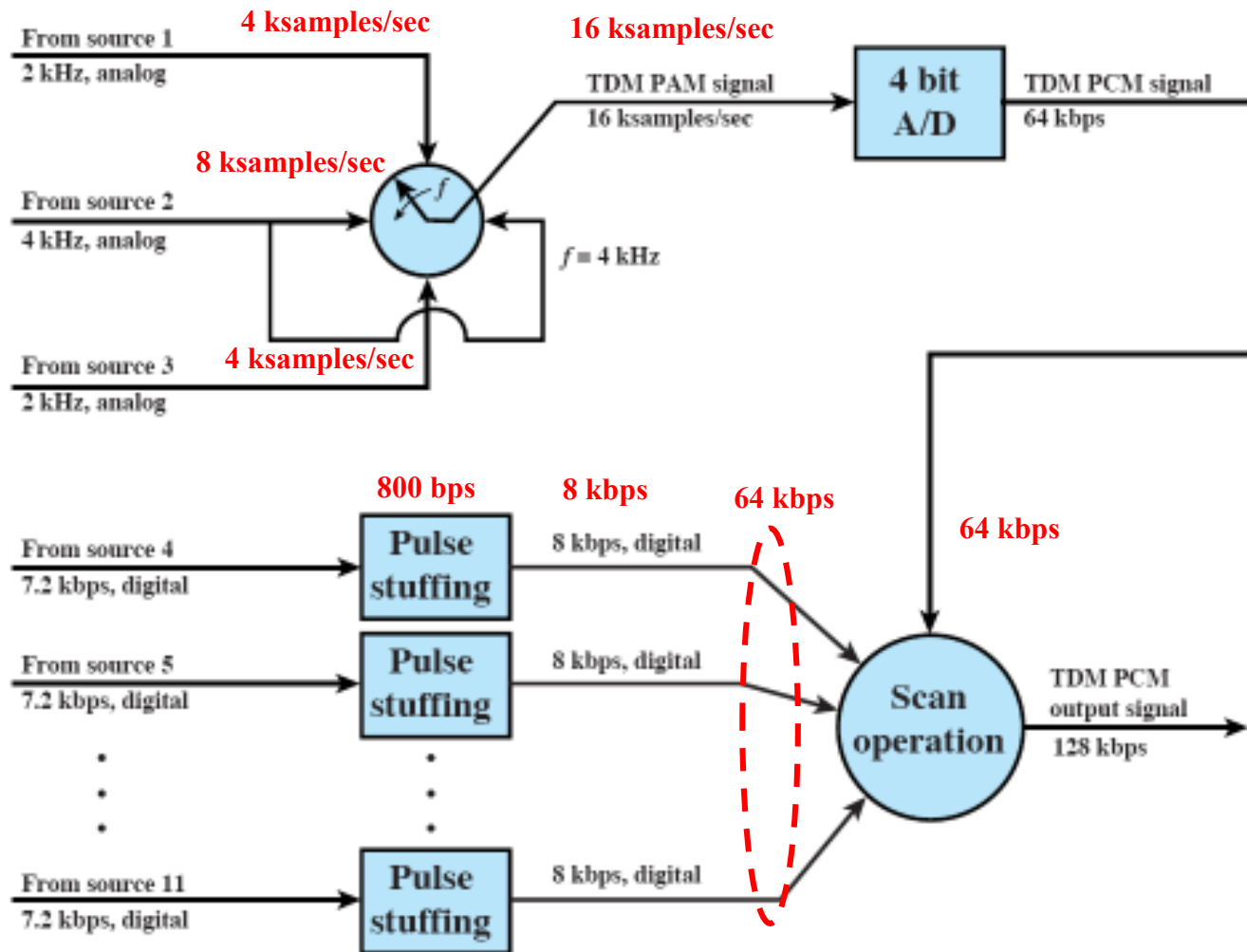

Pulse Stuffing - Example

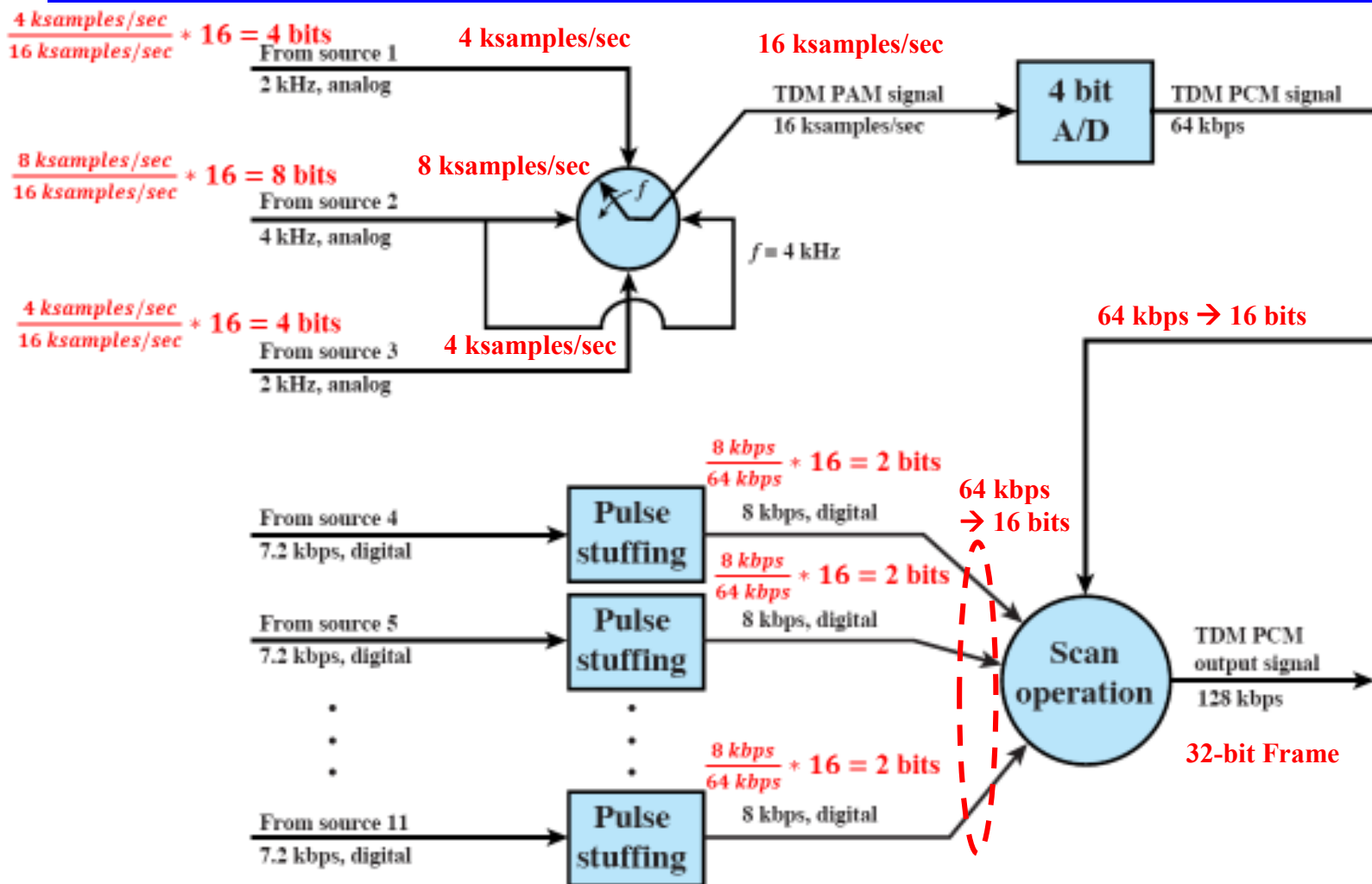

Digital Carrier Systems

- ⌘ Synchronous TDM transmission structure
- ⌘ TDM performed at multiple levels
- ⌘ Hierarchy of TDM structures
 - ☒ US, Canada, Japan use AT&T system
 - ☒ Other countries use ITU-T system

North American			International (ITU-T)		
Designation	Number of Voice Channels	Data Rate (Mbps)	Level	Number of Voice Channels	Data Rate (Mbps)
DS-1	24	1.544	1	30	2.048
DS-1C	48	3.152	2	120	8.448
DS-2	96	6.312	3	480	34.368
DS-3	672	44.736	4	1920	139.264
DS-4	4032	274.176	5	7680	565.148

T1 Carrier

- ⌘ long-distance links use an TDM hierarchy
- ⌘ AT&T (USA) and ITU-T (International) variants
- ⌘ The basis of the TDM hierarchy used in North America and Japan is the **Digital signal-1 (DS-1), also known as T1**
- ⌘ DS-1 can carry mixed voice and data signals
- ⌘ DS-1 frame consists of $24 \times 8 = 192$ data bits, plus one extra bit for framing, yielding 193 bits every 125 msec
- ⌘ aggregate data rate of $8000 \times 193 = 1.544$ Mbps
- ⌘ frame synchronization in DS-1 link uses an extra bit at the start of each frame which alternates between 1 and 0 for consecutive frames.
- ⌘ higher-level multiplexing is achieved by interleaving DS-1 inputs
 - ⌘ DS-2 is four DS-1 at 6.312Mbps

T1 Carrier

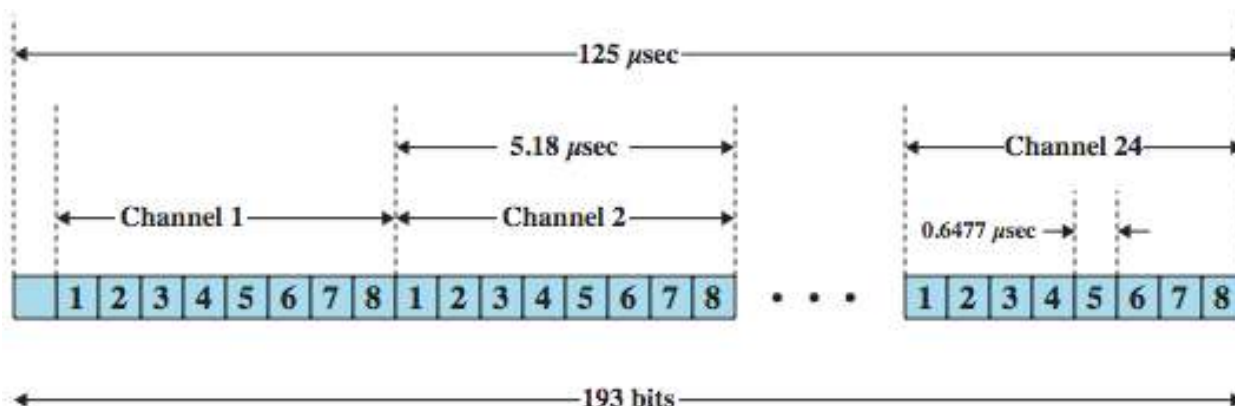

Notes:

1. The first bit is a framing bit, used for synchronization.
2. Voice channels:
 - 8-bit PCM used on five of six frames.
 - 7-bit PCM used on every sixth frame; bit 8 of each channel is a signaling bit.
3. Data channels:
 - Channel 24 is used for signaling only in some schemes.
 - Bits 1-7 used for 56 kbps service
 - Bits 2-7 used for 9.6, 4.8, and 2.4 kbps service.

T1 Carrier

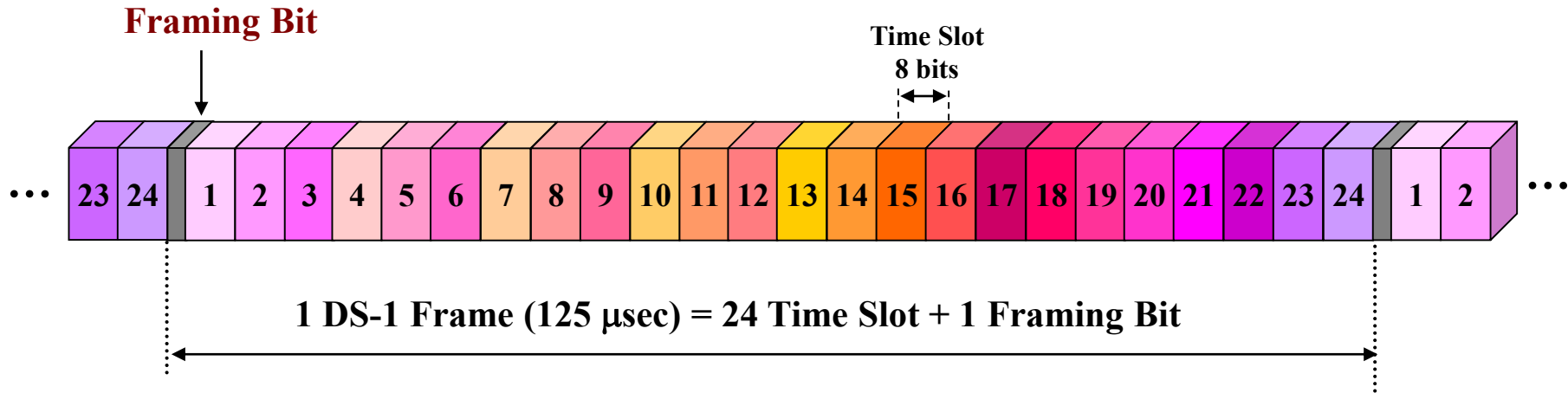

→ Aggregate data rate of 1.544 Mbps

T1 Carrier

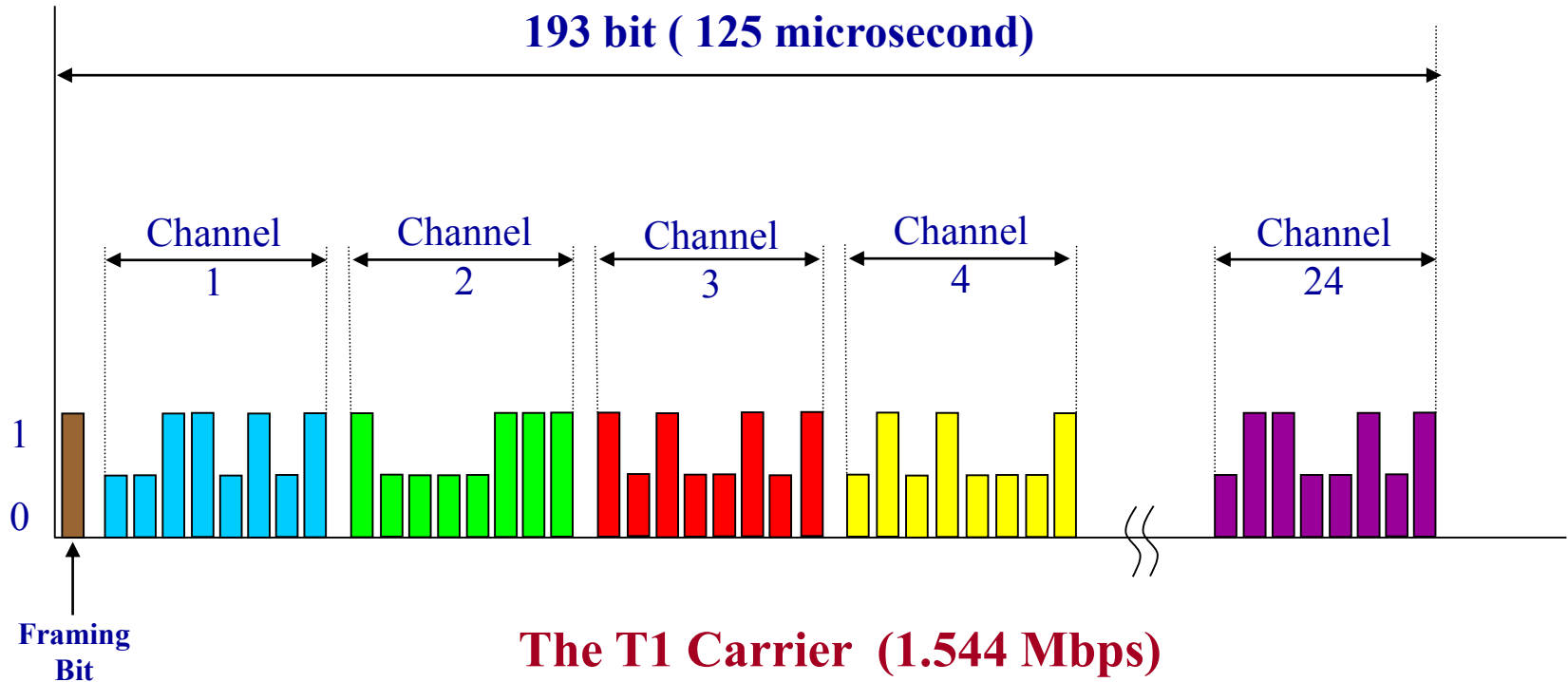

T1 Carrier

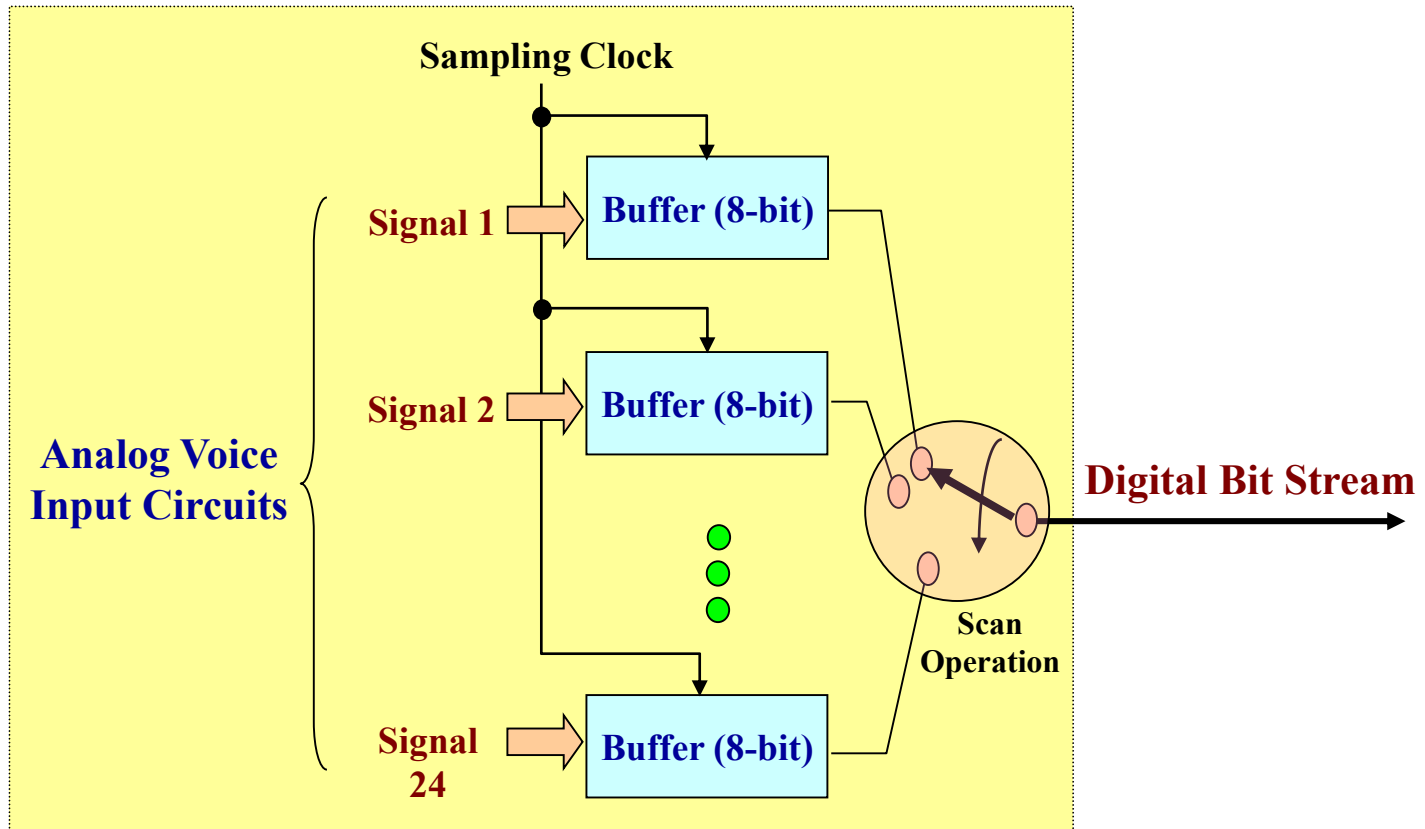



ANSI PDH Transmission Hierarchies

ANSI PDH Transmission Hierarchies.

Level	Multiplex Order	Bit Rate (Mbit/s)	Voice Channels
T0		0.064	1
T1	24 x T0	1.544	24
T2	4 x T1	6.312	96
T3	7 x T2	44.736	672
T4	3 x T3	139.264	2016



ANSI PDH Transmission Hierarchies

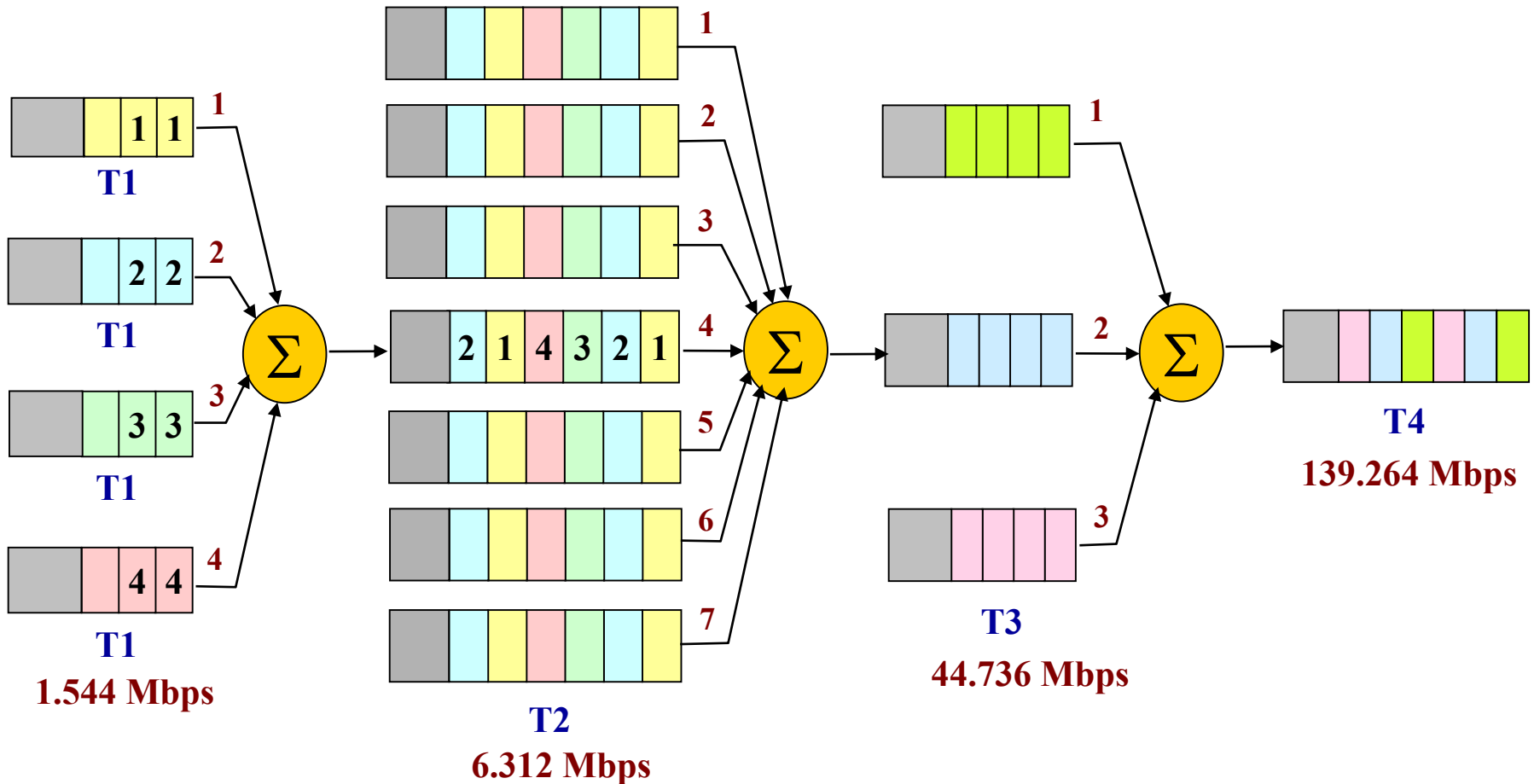

E1 Carrier

- ⌘ ITU-T recommends for a PCM carrier at 2.048 Mbps called **E1 Carrier**.
- ⌘ This carrier has 32 of 8-bit data samples, yielding 256 bits every 125 μ sec.
- ⌘ This gives the gross data rate of **2.048 Mbps**.
- ⌘ **Thirty** of the channels are used for information and two are used for signaling.
- ⌘ Outside North America and Japan, the E1 carrier is widely used.

E1 Carrier

1 E1 Frame = 125 μ sec = 32 Time Slot = 2.048 Mbps

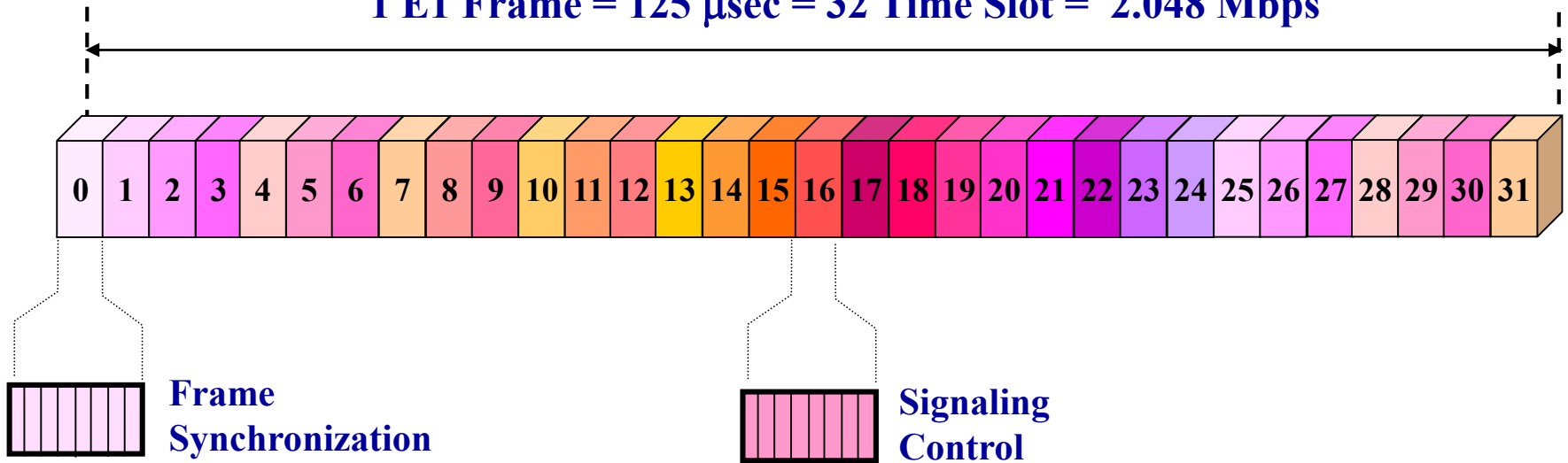



ITU-T PDH Transmission Hierarchies

ITU-T PDH Transmission Hierarchies.

Level	Multiplex Order	Bit Rate (Mbit/s)	Voice Channels
E0		0.064	1
E1	32 x E0	2.048	30
E2	4 x E1	8.448	120
E3	4 x E2	34.368	480
E4	4 x E3	139.264	1920
E5	4 x E4	565.148	7680



ITU-T PDH Transmission Hierarchies

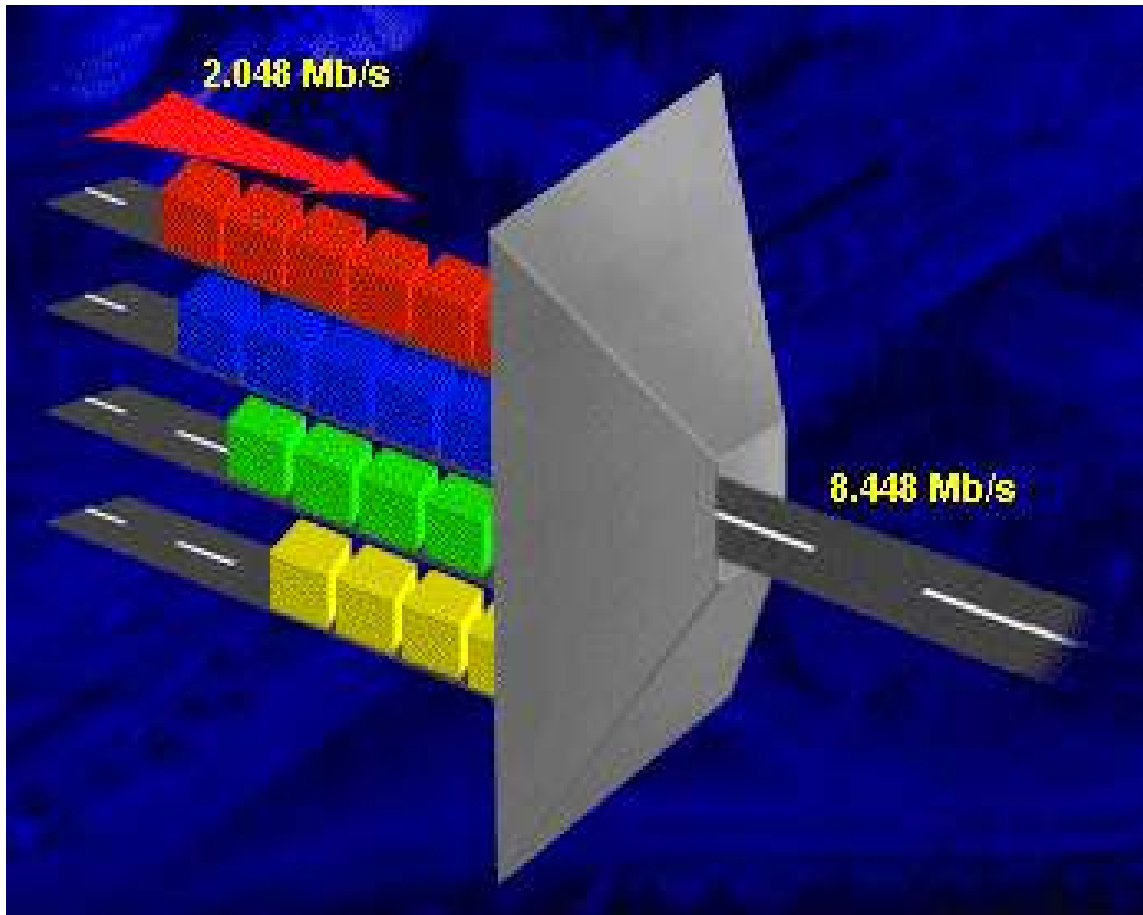



ITU-T PDH Transmission Hierarchies

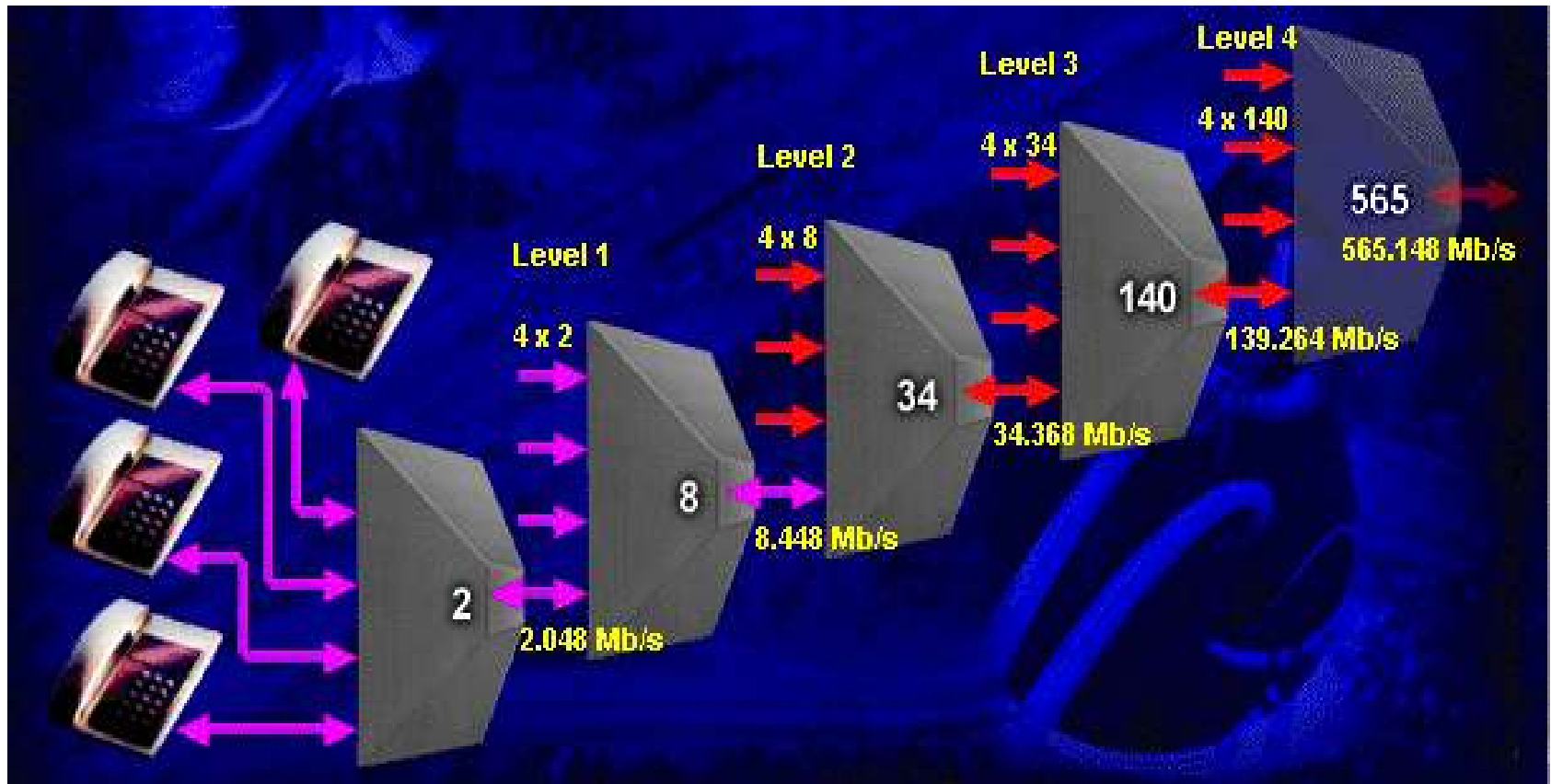

SONET/SDH

⌘ SONET (Synchronous Optical Network)

- ☒ optical transmission interface
- ☒ proposed by BellCore, standardize by ANSI

⌘ SDH (Synchronous Digital Hierarchy)

- ☒ compatible version published by ITU-T
- ☒ few differences from SONET

Synchronous Optical Network (SONET)

- ⌘ **Synchronous Optical Network (SONET)** is a digital transport system.
- ⌘ In SONET, the base transfer rate is 51.84 Mbps, a 125 μsec signal, and a frame format of 9 rows by 90 columns (90 columns * 9 rows * 8 bit/byte * 8000 = **51.84 Mbps**).
- ⌘ The basic rate of SONET, known as **Synchronous Transport Signal 1 (STS-1)**, is 51.84 Mbps.
- ⌘ SONET is the standard in North America, which is permitted to be multiplexed by an integer of **three** to the European preference of **155.520 Mbps**.

STS-1 Frame

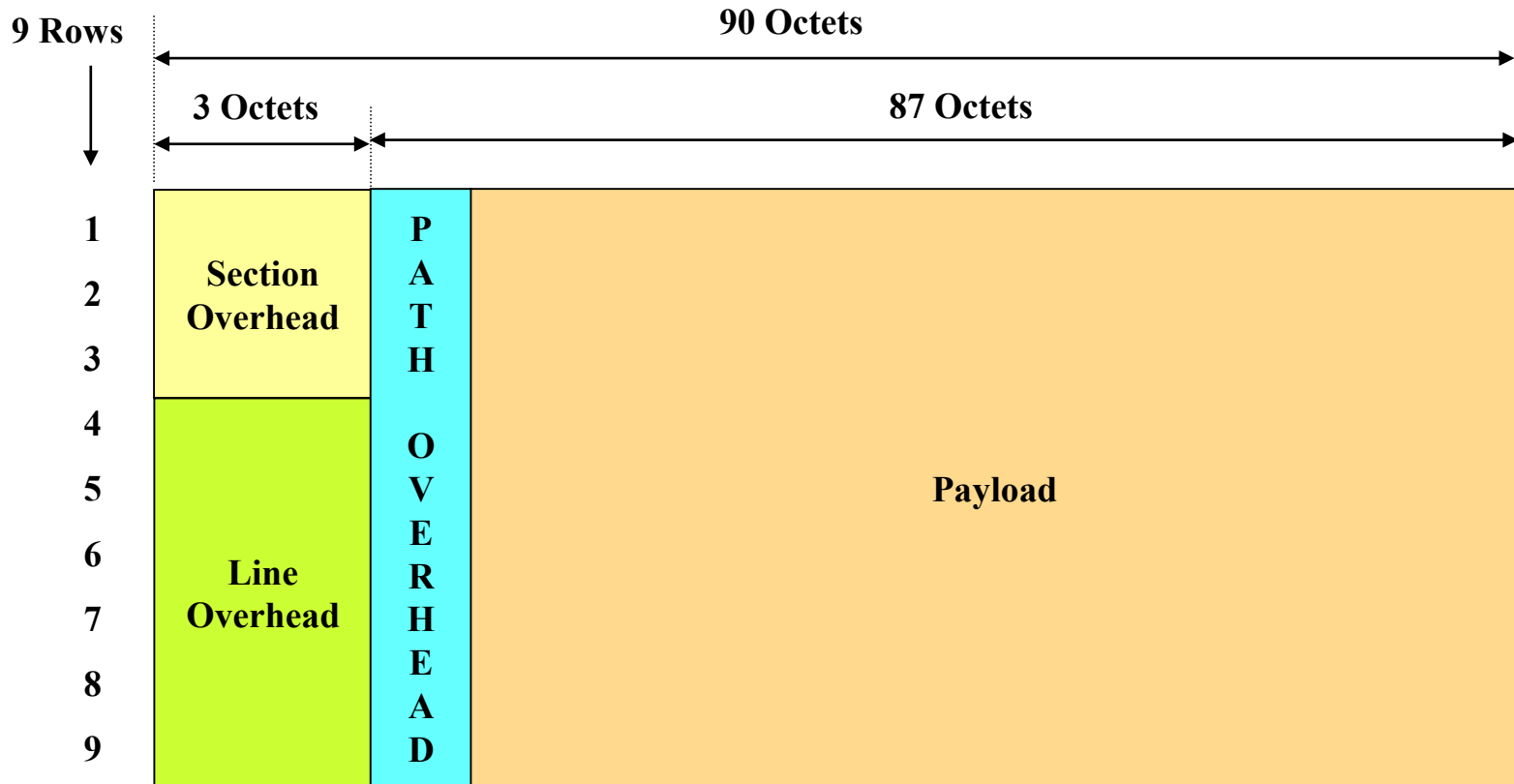

STS-1 Envelope

STS-1 Frame

Fiber Channel

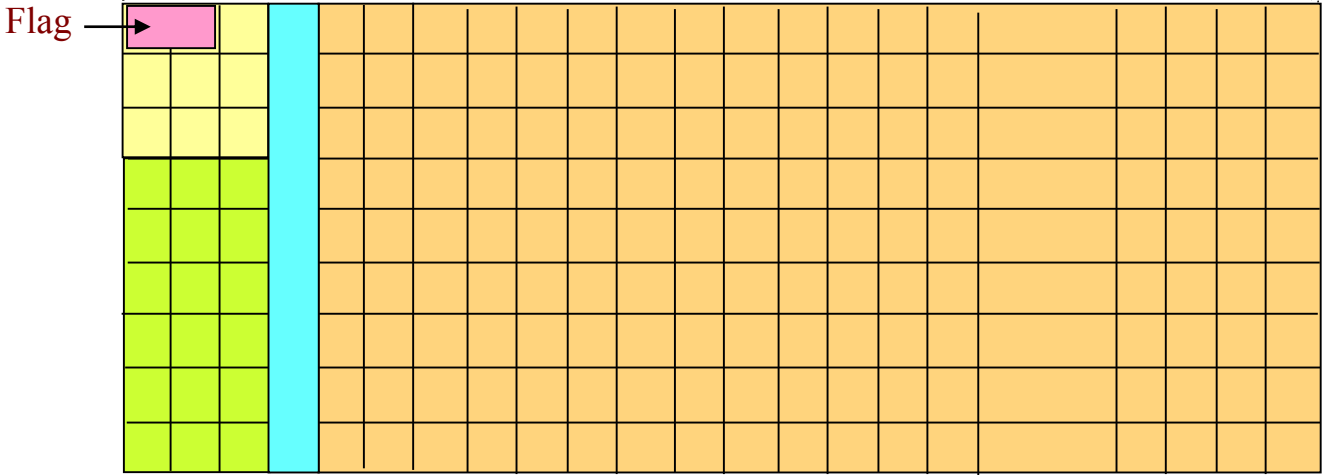
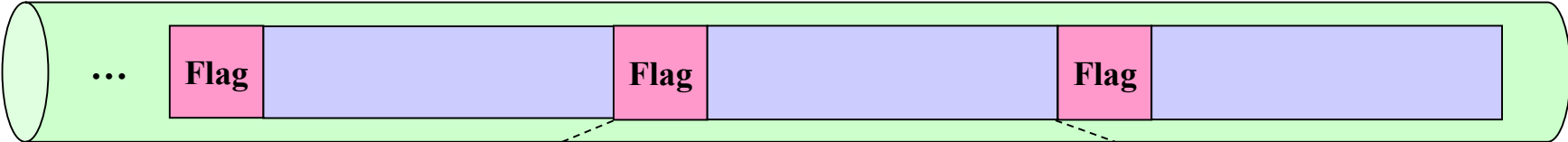

STS-1 Envelope



SONET Overheads

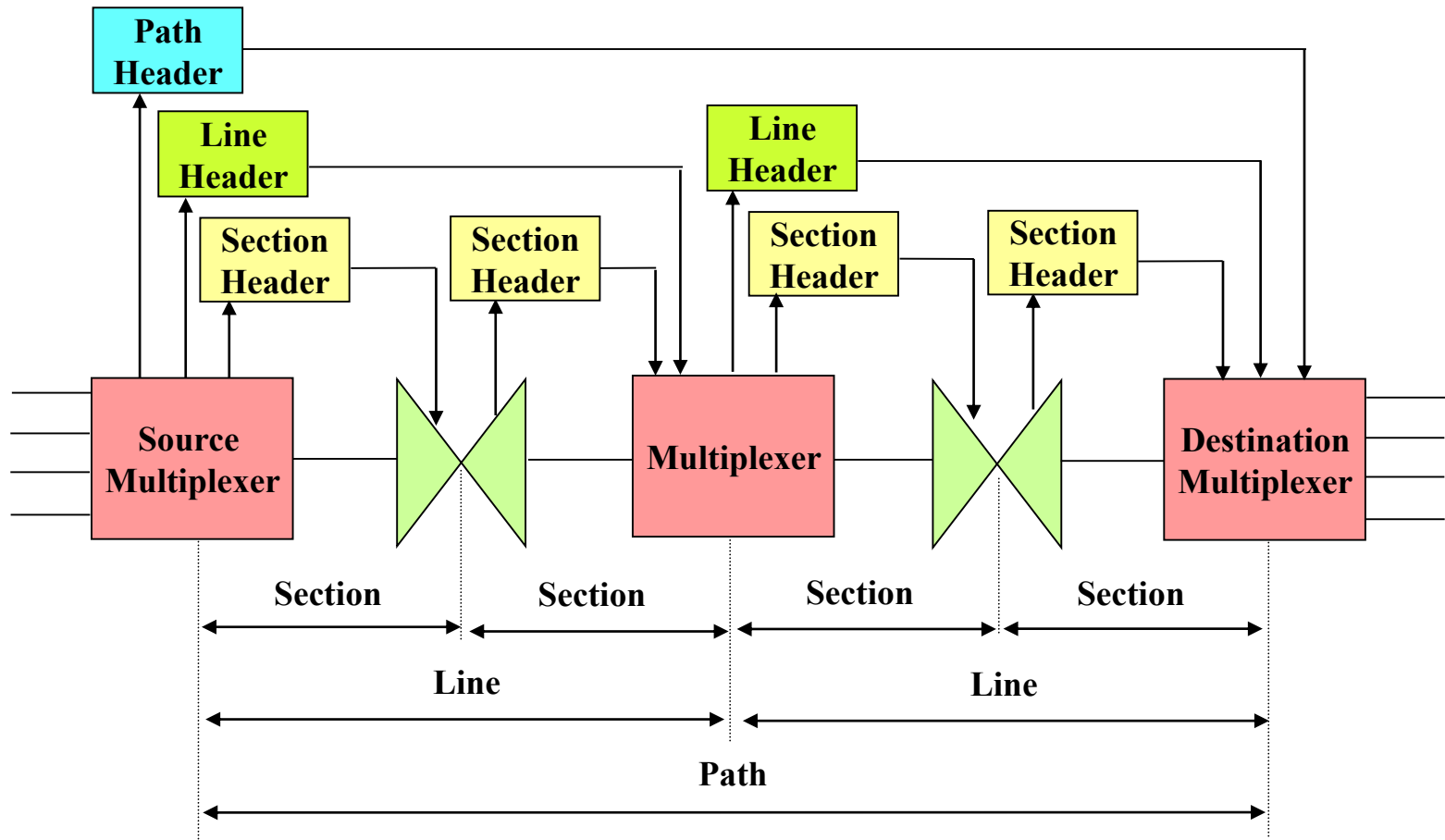



SONET Overheads

Section Overhead	Framing A1	Framing A2	STS-ID C1
	BIP-8 B1	Orderwire E1	User F1
	DataCom D1	DataCom D2	DataCom D3
Line Overhead	Pointer H1	Pointer H2	Pointer Action H3
	BIP-8 B2	APS K1	APS K2
	DataCom D4	DataCom D5	DataCom D6
	DataCom D7	DataCom D8	DataCom D9
	DataCom D10	DataCom D11	DataCom D12
	Growth Z1	Growth Z2	Orderwire E2

(a) Transport Overhead

Trace J1
BIP-8 B3
Signal Label C2
Path Status G1
User F2
Multiframe H4
Growth Z3
Growth Z4
Growth Z5

(b) Path Overhead



SONET Overheads

Section Overhead	
A1, A2:	Framing bytes = F6,28 hex used to synchronize the beginning of the frame.
C1:	STS-1 ID identifies the STS-1 number (1 to N) for each STS-1 within an STS-N multiplex.
B1:	Bit-interleaved parity byte providing even parity over previous STS-N frame after scrambling; the <i>i</i> th bit of this octet contains the even parity value calculated from the <i>i</i> th bit position of all octets in the previous frame.
E1:	Section level 64-kbps PCM orderwire; optional 64-kbps voice channel to be used between section terminating equipment, hubs, and remote terminals.
F1:	64-kbps channel set aside for user purposes
D1–D3:	192-kbps data communications channel for alarms, maintenance, control, and administration between sections.
Line Overhead	
H1–H3:	Pointer bytes used in frame alignment and frequency adjustment of payload data.
B2:	Bit-interleaved parity for line level error monitoring.
K1, K2:	Two bytes allocated for signaling between line level automatic protection switching equipment; uses a bit-oriented protocol that provides for error protection and management of the SONET optical link.
D4–D12:	576-kbps data communications channel for alarms, maintenance, control, monitoring, and administration at the line level.
Z1, Z2:	Reserved for future use.
E2:	64-kbps PCM voice channel for line level orderwire.
Path Overhead	
J1:	64-kbps channel used to send repetitively a 64-octet fixed-length string so a receiving terminal can continuously verify the integrity of a path; the contents of the message are user programmable.
B3:	Bit-interleaved parity at the path level, calculated over all bits of the previous SPE.
C2:	STS path signal label to designate equipped versus unequipped STS signals. <i>Unequipped</i> means the line connection is complete but there is no path data to send. For equipped signals, the label can indicate the specific STS payload mapping that might be needed in receiving terminals to interpret the payloads.
G1:	Status byte sent from path terminating equipment back to path originating equipment to convey status of terminating equipment and path error performance.
F2:	64-kbps channel for path user.
H4:	Multiframe indicator for payloads needing frames that are longer than a single STS frame; multiframe indicators are used when packing lower rate channels (virtual tributaries) into the SPE.
Z3–Z5:	Reserved for future use.



SONET - Section Overhead

SOH Section Overhead

A1, A2: Indicates the beginning of each STS-1 within a STS-n frame. The pattern is Hex F628.

J0: Section trace. It is defined only for STS-1 number 1 of an STS-N signal. Used to transmit a one byte fixed length string or a 16 byte message so that a receiving terminal in a section can verify its continued connection to the intended transmitter.

Z0: Section growth. It is defined in each STS-1 for future growth except for STS-1 number 1 (which is defined as J0).

B1: Section error monitoring. The BIP-8 is calculated over all bits of the previous STS-N frame after scrambling and is placed in the B1 byte of STS-1 number 1 before scrambling. Defined only for STS-1 number 1 of an STS-N signal.

E1: Allocated to be used as local orderwire channels for voice communication between section terminating equipments, hubs and remote terminal locations.

F1: Reserved for user purposes (e.g. temporary data/voice channel connections for special maintenance purposes).

D1 - D3: Data communication channels (DCC). A 192 kbit/s message based channel for alarms, maintenance, control, monitoring, administration and other communication needs.



SONET - Line Overhead

LOH Line Overhead

H1, H2: Pointer bytes. Allocated to a pointer that indicates the offset in bytes between pointer and the first byte of the STS SPE. It is used to align the STS-1 transport overheads in an STS-N signal as well as perform frequency justification.

H3: Pointer action byte. It is used for frequency justification. Depending on the pointer value, this byte is used to adjust the fill input buffers. It only carries valid information in the event of negative justification, otherwise it's not defined.

B2: Line error monitoring. The BIP-8 is used to determine if a transmission error has occurred over a line. It is calculated over all bits of the previous STS-1 frame before scrambling and is placed in the B2 byte of the current frame before scrambling.

K1, K2: Allocated for APS (Automatic Protection Switching) signaling for the protection of the multiplex section.

Linear APS messages

ANSI T1.105.01 protection switching protocol	
K1 byte	Condition
b1 - b4	
1111	Lockout of protection
1110	Forced switch
1101	Signal fail high priority
1100	Signal fail low priority
1011	Signal degrade high priority
1010	Signal degrade low priority
1001	Unused
1000	Manual switch
0111	Unused
0110	Wait-to-restore
0101	Unused
0100	Exercise
0011	Unused
0010	Reserve request
0001	Do not revert
0000	No request
b5 - b8	Selects channel used by APS messages
K2 byte	Condition

Ring APS messages

ANSI T1.105.01 protection switching protocol	
K1 byte	Condition
b1 - b4	
1111	Lockout of protection (span) or signal fail (protection)
1110	Forced switch (span)
1101	Forced switch (ring)
1100	Signal fail (span)
1011	Signal fail (ring)
1010	Signal degrade (protection)
1001	Signal degrade (span)
1000	Signal degrade (ring)
0111	Manual switch (span)
0110	Manual switch (ring)
0101	Wait-to-restore
0100	Exercise (span)
0011	Exercise (ring)
0010	Reserve request (span)
0001	Reserve request (ring)
0000	No request
b5 - b8	Destination node ID
K2 byte	Condition

b1 - b4	Selects bridged channel used	b1 - b4	Source node ID
b5	Determines automatic protection switch architecture	b5	Path code: 0 = short path; 1 = long path
b6 - b8	000 = Reserved for future use 001 = Reserved for future use 010 = Reserved for future use 011 = Reserved for future use 100 = Reserved for future use 101 = Reserved for future use 110 = MS-RDI 111 = MS-AIS	b6 - b8	000 = Idle 001 = Bridged 010 = Bridged and switched 011 = Reserved for future use 100 = Reserved for future use 101 = Reserved for future use 110 = MS-RDI

D4 - D12: Data Communication Channels (DCC). These 9 bytes form a 576 kbit/s message channel for alarms, maintenance, control, monitor, administration and other communication needs between line-terminating entities.

S1: Synchronization messaging. Bits 5 - 8 are used to carry the synchronization status messages which provide an indication of the quality level of the synchronization source of the SONET signal. Bits 1 - 4 are reserved for future use.

SONET Synchronization Status Messages

S1 byte b5 - b8	SONET synchronization quality level description
0000	Synchronized-traceability unknown
0001	Stratum 1 traceable
0111	Stratum 2 traceable
1010	Stratum 3 traceable
1100	±20 ppm clock traceable
1110	Reserved for network synchronization
1111	Don't use for synchronization

M0: Only defined for STS-1 signal. Bits 5 - 8 are used as a line REI function. They convey the count of errors detected by B2. Bits 1 - 4 are reserved for future use.

M1: This byte is located in the third STS-1 in order of appearance in the byte interleaved STS-N frame and is used as a line REI function. It conveys the count of errors detected by B2.

Z1: In SONET signals and at rates above STS-1 and below STS-192, this byte is defined in each STS-1 number 1 for future growth.

Z2: In SONET signals and at rates above STS-1 and below STS-192, this byte is defined in each STS-1 except the third STS-1 for future growth.

E2: Allocated for an express orderwire between line entities. It is defined only for STS-1 number 1 of an STS-N signal and its use is optional.



SONET - Path Overhead

STS POH STS Path Overhead

J1: STS path trace. It is used to transmit a 64-byte, fixed-length string so that a receiving terminal can verify its continued connection to the intended transmitter.

B3: Path error monitoring. The BIP-8 is calculated over all bits of the previous STS SPE before scrambling. Computed value is placed in the B3 byte.

C2: Signal label. Allocated to identify the construction and content of the STS-level SPE and for RDI-P.

C2 byte coding

Code [hex]	Payload type
00	Unequipped
01	Equipped - nonspecific
02	Floating VT mode
03	Locked VT mode
04	Asynchronous mapping for DS3
12	Asynchronous mapping for 139.264 Mbit/s
13	Mapping for ATM
14	Mapping for DQDB
15	Asynchronous mapping for FDDI
16	Mapping for HDLC over SONET
E1	STS-1 payload with 1 VT-x payload defects
E2	STS-1 payload with 2 VT-x payload defects
F3	STS-1 payload with 3 VT-x payload defects
F4	STS-1 payload with 4 VT-x payload defects
F5	STS-1 payload with 5 VT-x payload defects
F6	STS-1 payload with 6 VT-x payload defects
E7	STS-1 payload with 7 VT-x payload defects
E8	STS-1 payload with 8 VT-x payload defects
E9	STS-1 payload with 9 VT-x payload defects
EA	STS-1 payload with 10 VT-x payload defects
EB	STS-1 payload with 11 VT-x payload defects
EC	STS-1 payload with 12 VT-x payload defects
ED	STS-1 payload with 13 VT-x payload defects
EE	STS-1 payload with 14 VT-x payload defects
EF	STS-1 payload with 15 VT-x payload defects
F0	STS-1 payload with 16 VT-x payload defects
F1	STS-1 payload with 17 VT-x payload defects
F2	STS-1 payload with 18 VT-x payload defects
F3	STS-1 payload with 19 VT-x payload defects
F4	STS-1 payload with 20 VT-x payload defects
F5	STS-1 payload with 21 VT-x payload defects
F6	STS-1 payload with 22 VT-x payload defects
F7	STS-1 payload with 23 VT-x payload defects
F8	STS-1 payload with 24 VT-x payload defects
F9	STS-1 payload with 25 VT-x payload defects
FA	STS-1 payload with 26 VT-x payload defects
FB	STS-1 payload with 27 VT-x payload defects
FC	STS-1 payload with 28 VT-x payload defects, or STS-1, STS-3c, etc. with a non-VT payload defect (DS3, FDDI, etc.)

G1: Path status. Allocated to convey back to an originating STS SPE the path-terminating status and performance. Bits 1 - 4 convey the count of interleaved bit blocks that have been detected in error by B3. Bits 5 - 7 provide codes to indicate both an old version and an enhanced version of the STS RDI-P.

G1, RDI-P defects

REI				RDI-P			Spare
b1	b2	b3	b4	b5	b6	b7	b8
				↓			
b5	b6	b7	Interpretation		Triggers		
0	0	0	No remote defect		No defects		
0	0	1	No remote defect		No defects		
0	1	0	Remote payload defect		PLM-P		
0	1	1	No remote defect		No defects		
1	0	0	Remote defect		AIS-P, LOP-P		
1	0	1	Remote server defect		AIS-P, LOP-P		
1	1	0	Remote connectivity defect		TIM-P, UNEQ-P		
1	1	1	Remote defect		AIS-P, LOP-P		

F2: Path user channel. Allocated for user communication purposes between path elements.

H4: Multiframe indicator. Provides a generalized multiframe indicator for payloads. Currently, it is only used for VT-structured payloads.

Z3, Z4: Allocated for future use. Have no defined value. The receiver is required to ignore their content.

N1: Allocated to support tandem connection maintenance and the tandem connection link.

Bits 1 - 4 are used to provide the tandem connection incoming Error Count (IEC). In option 1, bits 5 - 8 are used to provide the tandem connection data link which is an optional 32 kbit/s data channel available to applications or services that span more than one LTE-LTE connection, but may be shorter than a PTE-PTE connection. In option 2, bits 5 - 8 are used to provide maintenance information including REI, outgoing error indication, RDI, outgoing defect information and TC access point identifier.

Synchronous Digital Hierarchy (SDH)

- ⌘ In SDH, the base **transfer rate** is 155.52 Mbps, a 125 μsec signal, and a frame format of 9 rows by 270 columns (270 columns * 9 rows * 8 bit/byte * 8000 = 155520000 bps).
- ⌘ The basic rate of SDH, known as **Synchronous Transport Module 1 (STM-1)**, is 155.52 Mbps.
- ⌘ SDH is a European Standard and was developed by **ITU-T**.

Synchronous Digital Hierarchy (SDH)

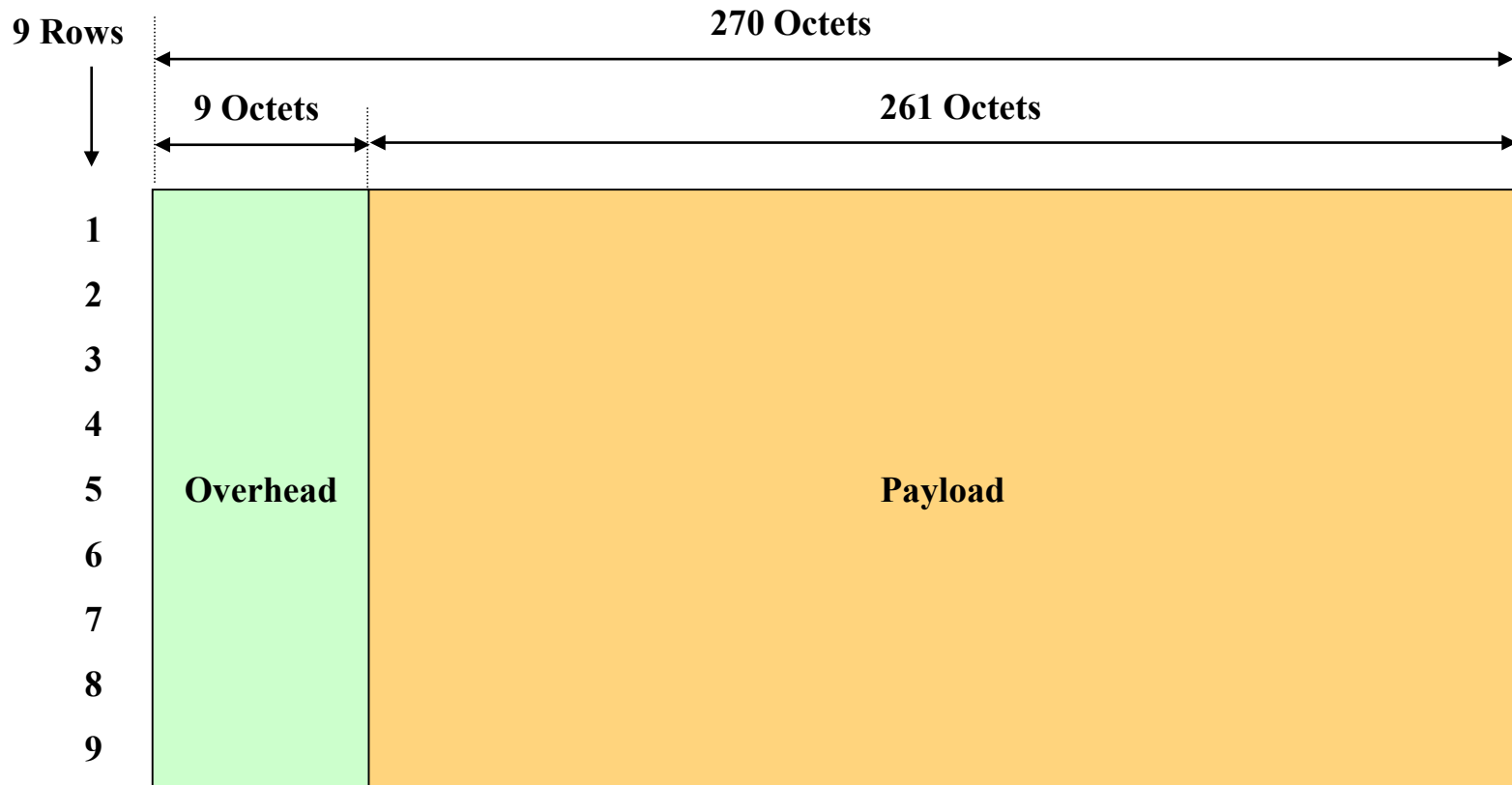

SDH Envelope



SONET/SDH Multiplexing

Order of transmission

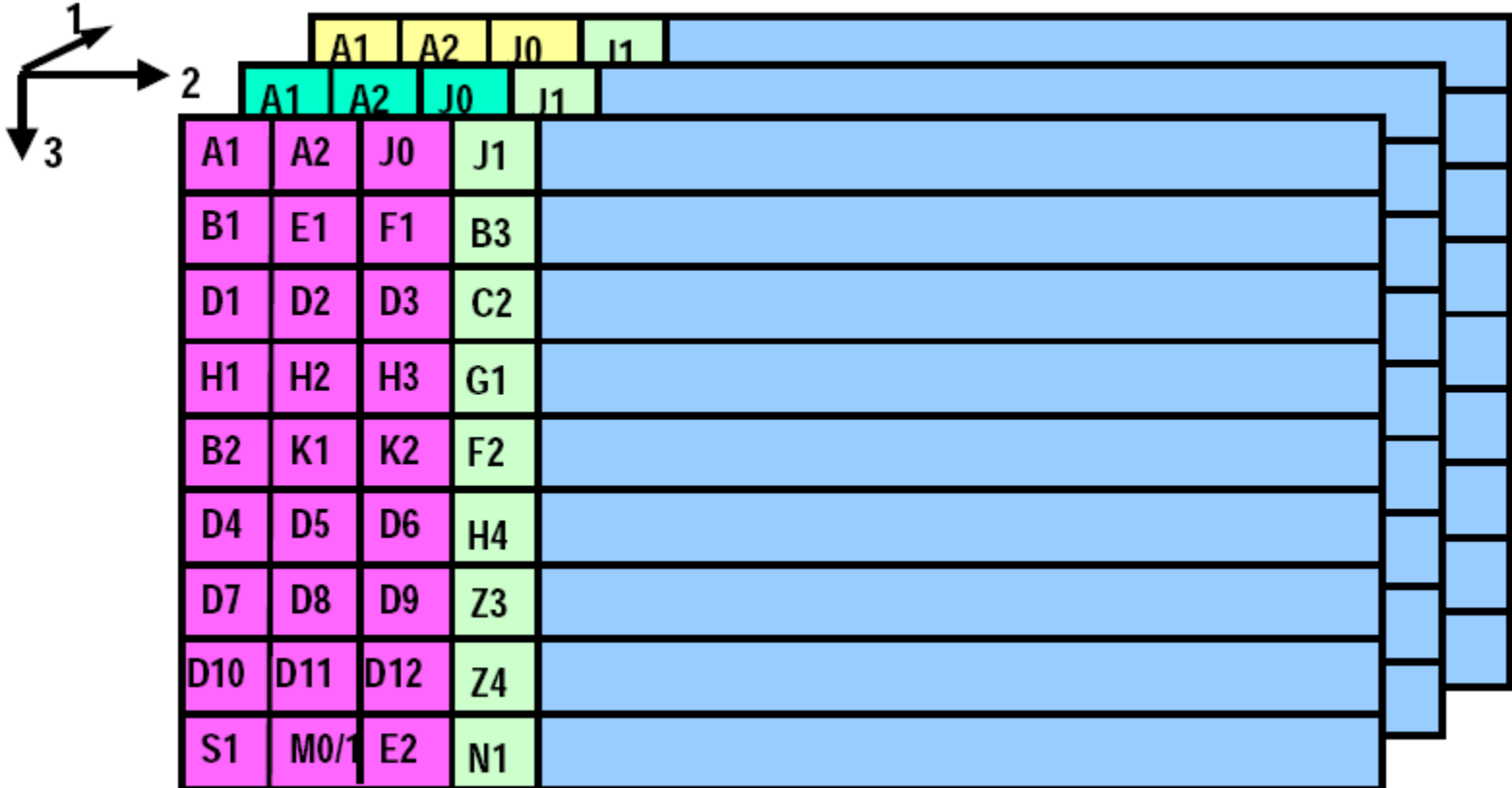

Interleaving of three SONET STS-1 frames into an STS-3 frame



SONET/SDH Multiplexing

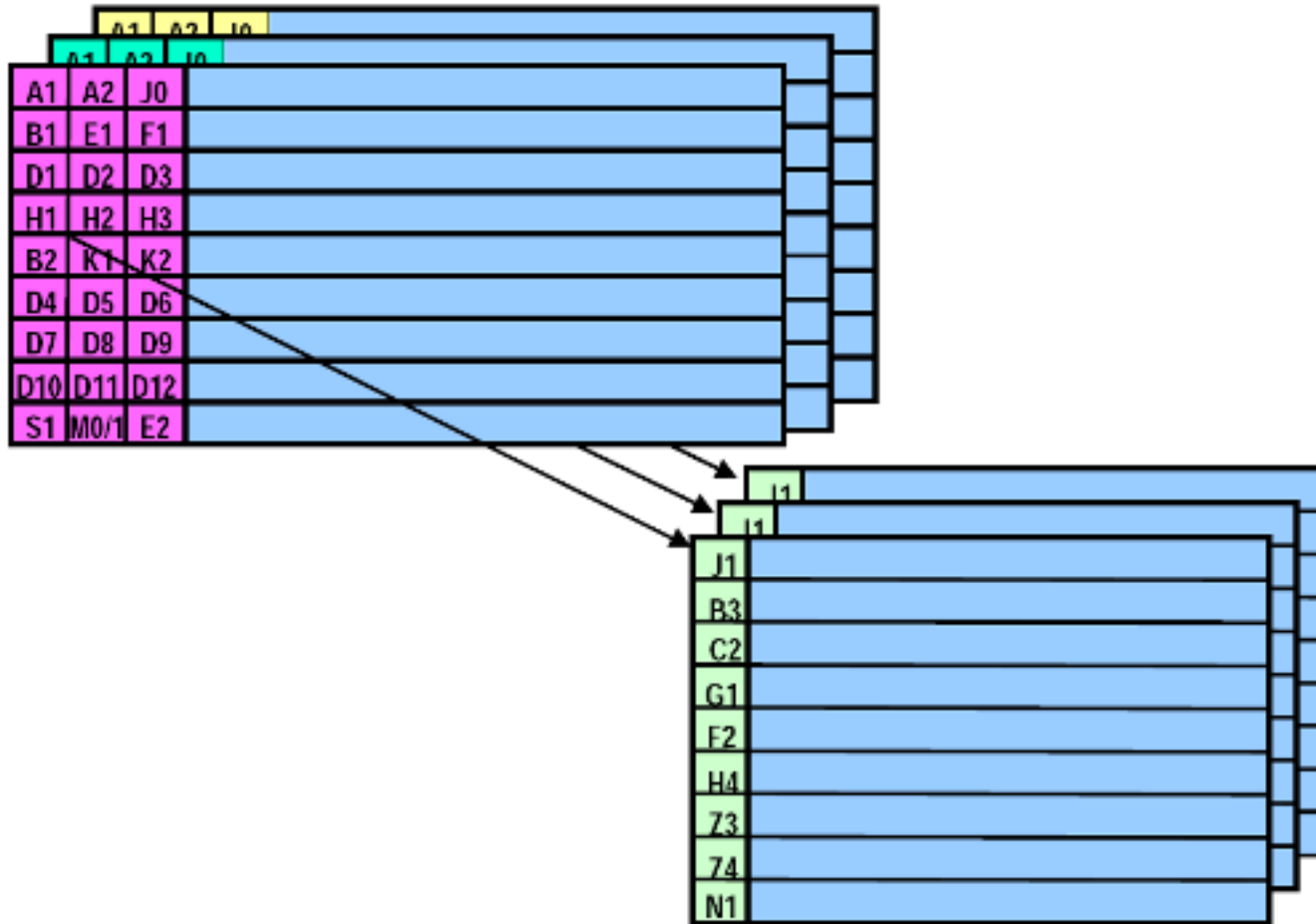

Three individual STS-1 payloads carried in an STS-3 signal



SONET/SDH Multiplexing

A1	A1	A1	A2	A2	A2	J0	Z0	Z0	
B1	X	X	E1	X	X	F1	X	X	
D1	X	X	D2	X	X	D3	X	X	
H1	H1	H1	H2	H2	H2	H3	H3	H3	
B2	B2	B2	K1	X	X	K2	X	X	
D4	X	X	D5	X	X	D6	X	X	
D7	X	X	D8	X	X	D9	X	X	
D10	X	X	D11	X	X	D12	X	X	
S1	Z1	Z1	M0/1	Z2	M2	E2	X	X	



First STS-1



Second STS-1



Third STS-1

A SONET STS-3 frame showing how the STS-1s are interleaved



Payload Pointer

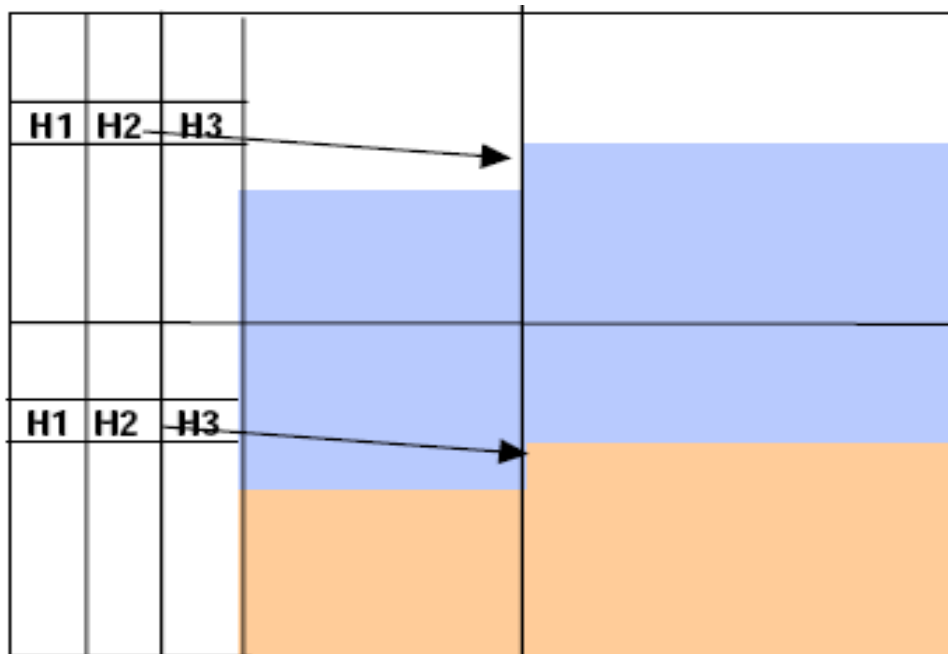



Payload Pointer

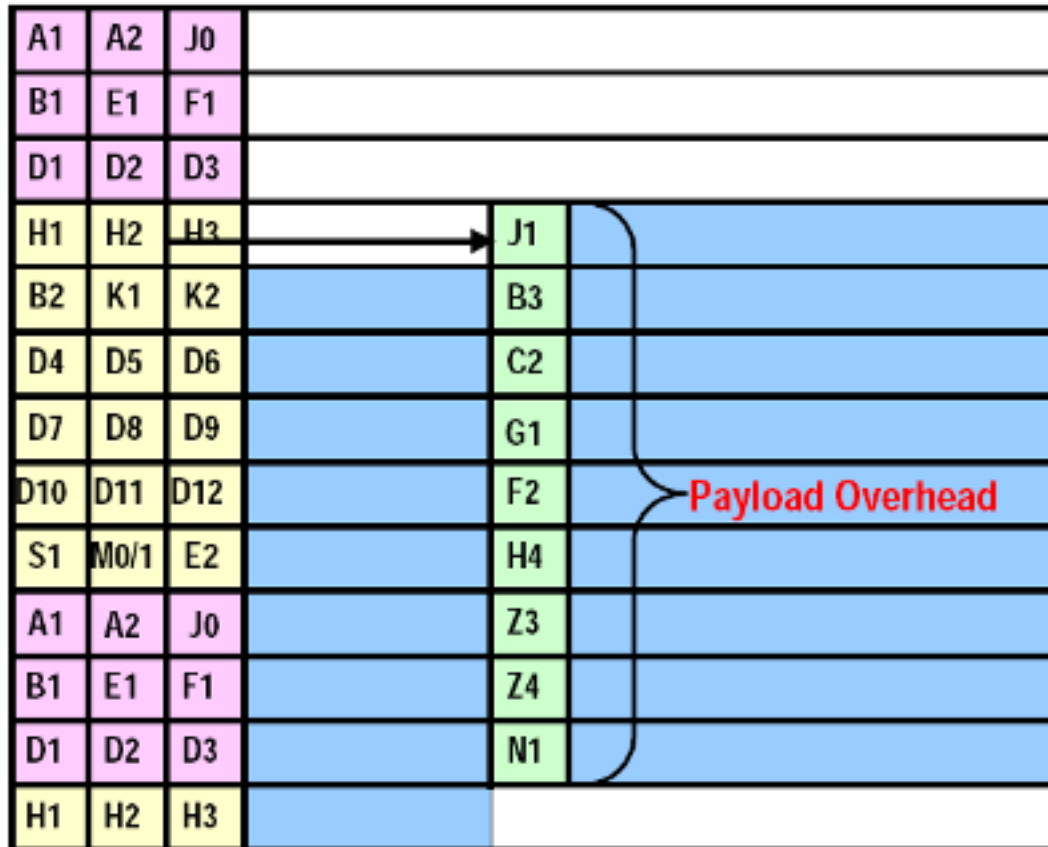

Payload overhead (POH) is the first column of the synchronous payload envelope (SPE)

STS-1 SPE for all VT1.5 (T1 Container)

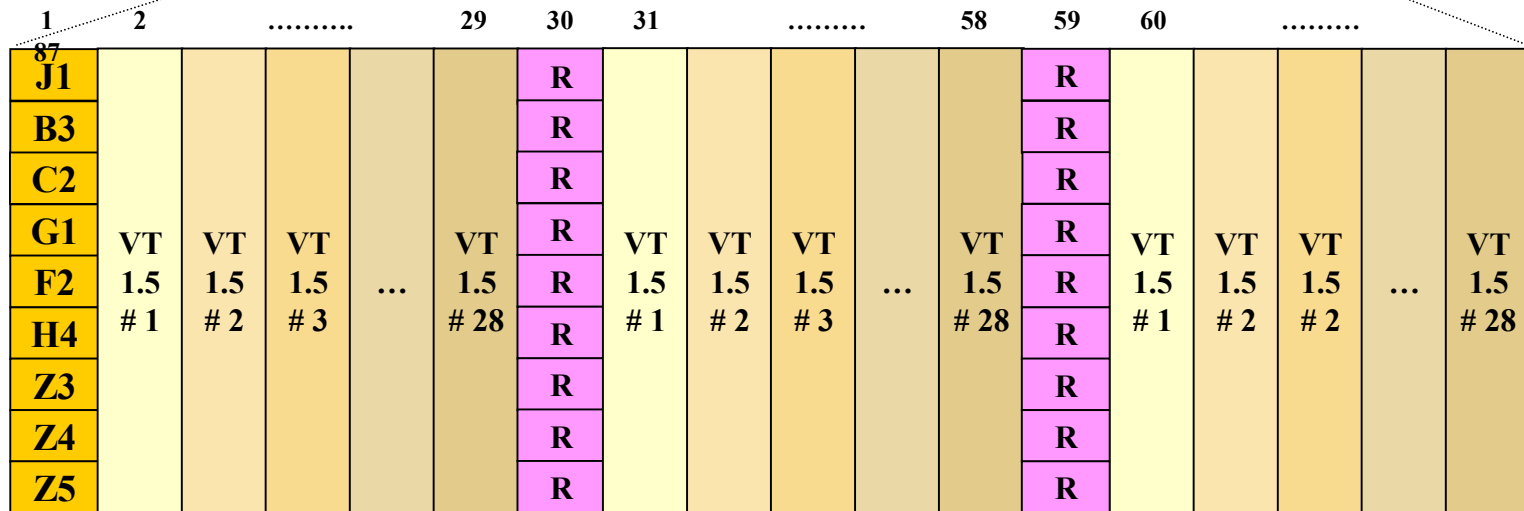
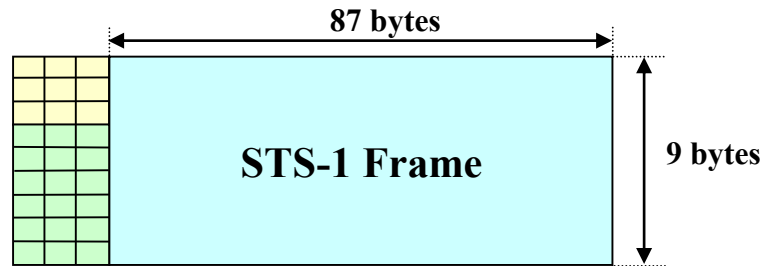

STS-1 Path
Overhead

Fixed Stuff byte

STS-1 SPE for all VT2 (E1 Container)

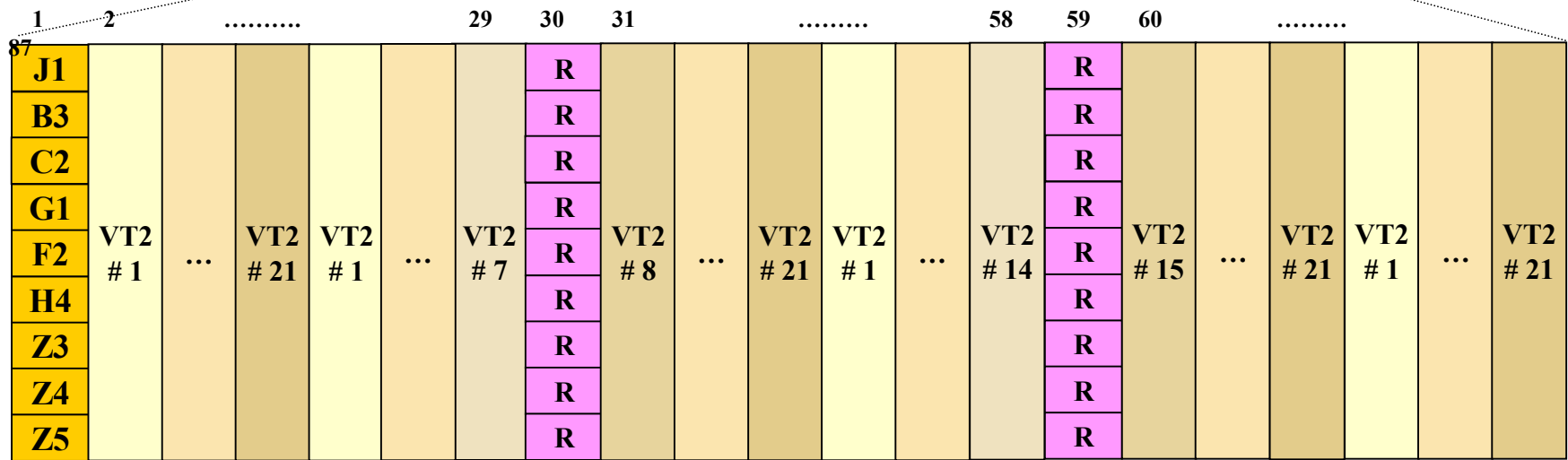
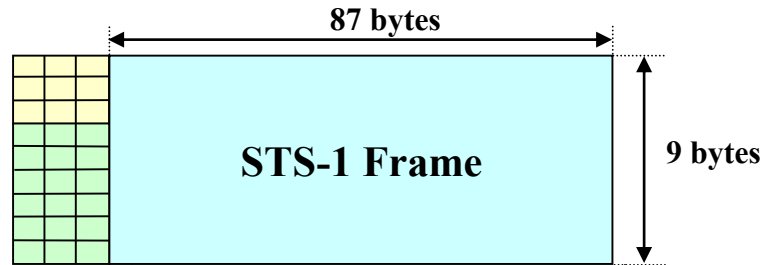

STS-1 Path Overhead

Fixed Stuff byte

SONET/SDH

- ⌘ **STS-1** → **28 T1 Links**
 → **21 E1 Links**

- ⌘ **STS-N** → **N*28 T1 Links**
 → **N*21 E1 Links**

- ⌘ **STM-1** → **3 STS-1**
 → **3*28 T1 Links**
 → **3*21 E1 Links**

- ⌘ **STM-N** → **N*3 STS-1**
 → **N*3*28 T1 Links**
 → **N*3*21 E1 Links**

SONET/SDH

- ⌘ Synchronous Optical Network (ANSI)
- ⌘ Synchronous Digital Hierarchy (ITU-T)
- ⌘ have hierarchy of signal rates
 - ☒ Synchronous Transport Signal level 1 (STS-1) or Optical Carrier level 1 (OC-1) is 51.84Mbps
 - ☒ carries one DS-3 or multiple (DS1 DS1C DS2) plus ITU-T rates (eg. 2.048Mbps)
 - ☒ multiple STS-1 combine into STS-N signal
 - ☒ ITU-T lowest rate is 155.52Mbps (STM-1)

SONET/SDH

SONET		SDH Optical	Transmission rate (Mbps)	DS-3 Equiv. #	DS-1 Equiv. #	DS-0 Equiv. #
Electrical	Optical					
STS-1	OC-1		51.840	1	28	672
STS-3	OC-3	STM-1	155.520	3	84	2016
STS-9	OC-9	STM-3	466.560	9	252	6048
STS-12	OC-12	STM-4	622.080	12	336	8064
STS-18	OC-18	STM-6	933.120	18	504	12096
STS-24	OC-24	STM-8	1244.160	24	672	16128
STS-36	OC-36	STM-12	1866.240	36	1008	24192
STS-48	OC-48	STM-16	2488.320	48	1344	32256
STS-192	OC-192	STM-64	9953.280	192	5376	129024

Statistical TDM

- ⌘ in **Synchronous TDM** many slots **are wasted**
- ⌘ Statistical TDM allocates time slots dynamically based on demand
- ⌘ multiplexer scans input lines and collects data until frame full
- ⌘ There are n I/O lines and k time slots available on the TDM frame, where $k < n$
- ⌘ **line data rate lower than aggregate input line rates**
- ⌘ **may have problems during peak periods**
 - ⊞ **must buffer inputs**

Statistical TDM

- ⌘ Output data rate **is less than** the sum input rates
- ⌘ Can take **more sources** than synchronous TDM at same output rate **or less output rate** for same sources as synchronous TDM
- ⌘ Statistical Multiplexer **does not send empty slots if there are data to send**
- ⌘ More **overhead** than TDM
 - ⌘ slot positions must be identified → **address information must be included with data**

Statistical TDM

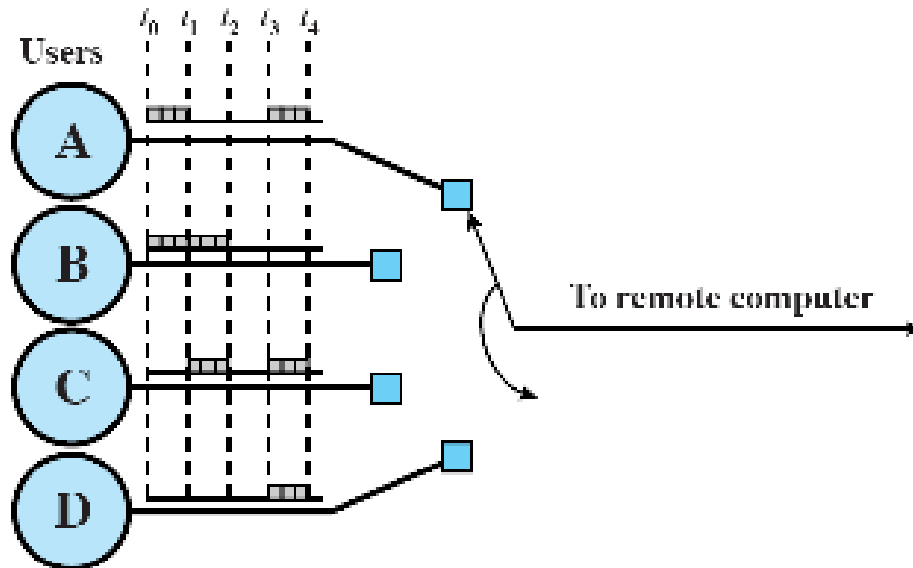

Synchronous time
division multiplexing



Statistical time
division multiplexing



LEGEND

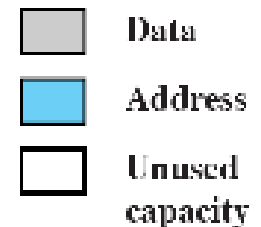



Frame Structure

⌘ Control information is needed

Two possible formats:

⌘ **One data source per frame**

☑ need to identify address of source

☑ work well under light load

☑ inefficient under heavy load

⌘ **Multiple sources per frame**

☑ need to identify length of data of each source



Statistical TDM Frame Format



(a) Overall frame



(b) Subframe with one source per frame



(c) Subframe with multiple sources per frame



Statistical TDM - Performance

⌘ Parameters for statistical TDM:

⊠ I = number of Input sources

⊠ R = data rate of each source, bps

⊠ μ = effective capacity of multiplexed line, bps

⊠ α = mean fraction of time each source is transmitting, $0 < \alpha < 1$

⊠ $K = \frac{\mu}{IR}$ = ratio of multiplexed line capacity to total maximum input

⌘ If $K=0.25$ → four times as many devices using the same link capacity

⌘ K can be bounded: $\alpha < K < 1$

⊠ If $K = 1$ → Synchronous TDM

⊠ if $K < \alpha$, then a single input will exceed the multiplexer capacity



Statistical TDM - Performance

M/M/1 Queue

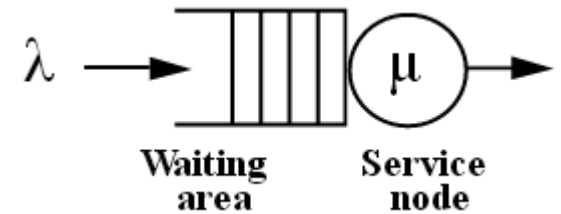
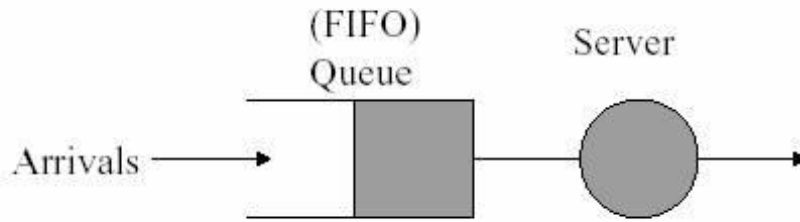

- Notation

- Arrivals process λ
- Service Distribution $A/B/C$
- Number of Servers n

- $M \equiv$ Markov process. Transition probabilities depend only on current state. Memoryless.
- Poisson/Exponential is special case of Markov.



Statistical TDM - Performance

⌘ Viewing the multiplexer as a single-server queue, and assuming Poisson arrivals and constant service time

⌘ Parameters:

☒ λ = arrival rate (mean number of arrivals per second)

☒ μ = mean service rate

☒ T_s = service time for each arrival $T_s = \frac{1}{\mu}$

☒ ρ = utilization, fraction of time server is busy $\rho = \frac{\lambda}{\mu}$

☒ N_w = mean number of waiting items in the system

☒ N = mean number of items in the system (waiting + being served)

$$\rightarrow N = N_w + \rho$$

☒ T_r = residence time, mean time an item spends in the system
(waiting + being served)

☒ σ_r = standard deviation of T_r



Statistical TDM - Performance

⌘ Formulas:

λ = Mean number of arrivals per second $\lambda = \alpha IR$

T_s = service time for each arrival $T_s = \frac{1}{\mu}$

ρ = Utilization, fraction of time server is busy

$$\rho = \frac{\lambda}{\mu} = \lambda T_s$$

$$\rho = \frac{\lambda}{\mu} = \frac{\alpha IR}{\mu} = \frac{\alpha}{K}$$

N_w = mean number of waiting items in the system

$$N_w = \frac{\rho^2}{2(1-\rho)}$$

N = mean number of items in the system

$$N = \frac{\rho^2}{2(1-\rho)} + \rho$$

Little's Law tells us that the average number of customers in the system N , is the effective arrival rate λ , times the average time that a customer spends in the system T_r , or simply:

N = mean number of items in the system

$$N = \lambda T_r \rightarrow T_r = \frac{N}{\lambda}$$

T_r = Mean time an item spends in the system

$$T_r = \frac{N}{\lambda} = \frac{N}{\rho / T_s} = \frac{T_s}{\rho} \left(\frac{\rho^2}{2(1-\rho)} + \rho \right) = \frac{T_s}{\rho} \left(\frac{\rho^2 + 2\rho - 2\rho^2}{2(1-\rho)} \right) = \frac{T_s}{\rho} \left(\frac{2\rho - \rho^2}{2(1-\rho)} \right) = \frac{T_s(2-\rho)}{2(1-\rho)}$$

σ_r = standard deviation of T_r

$$\sigma_r = \frac{1}{(1-\rho)} \sqrt{\rho - \frac{3\rho^2}{2} + \frac{5\rho^3}{6} - \frac{\rho^4}{12}}$$



Statistical TDM - Performance

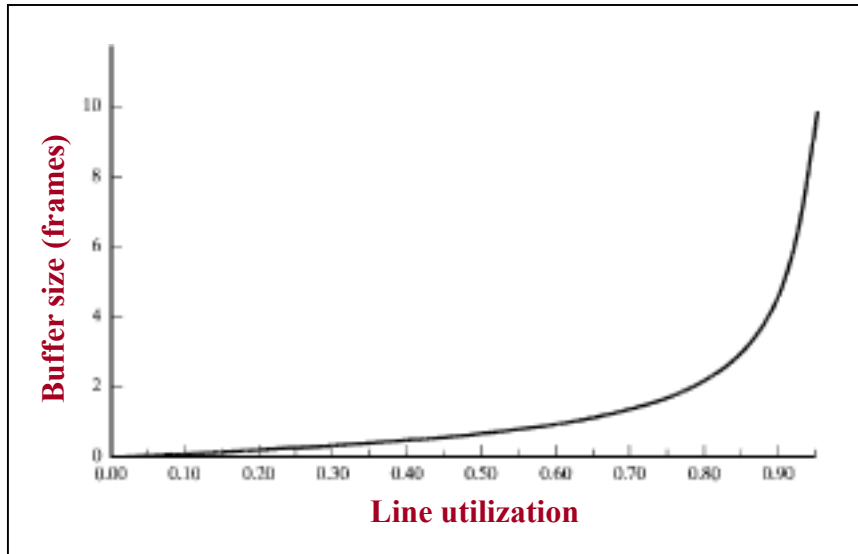

Mean buffer size versus utilization

$$N_w = \frac{\rho^2}{2(1-\rho)}$$

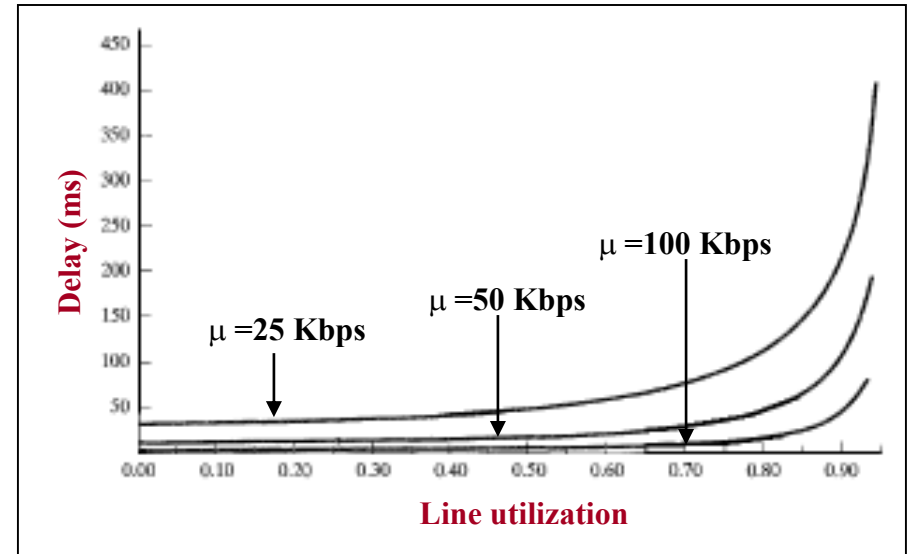

Mean delay versus utilization

$$T_r = \frac{T_s(2-\rho)}{2(1-\rho)}$$

$$T_s = \frac{1}{\mu}$$



Statistical TDM - Performance

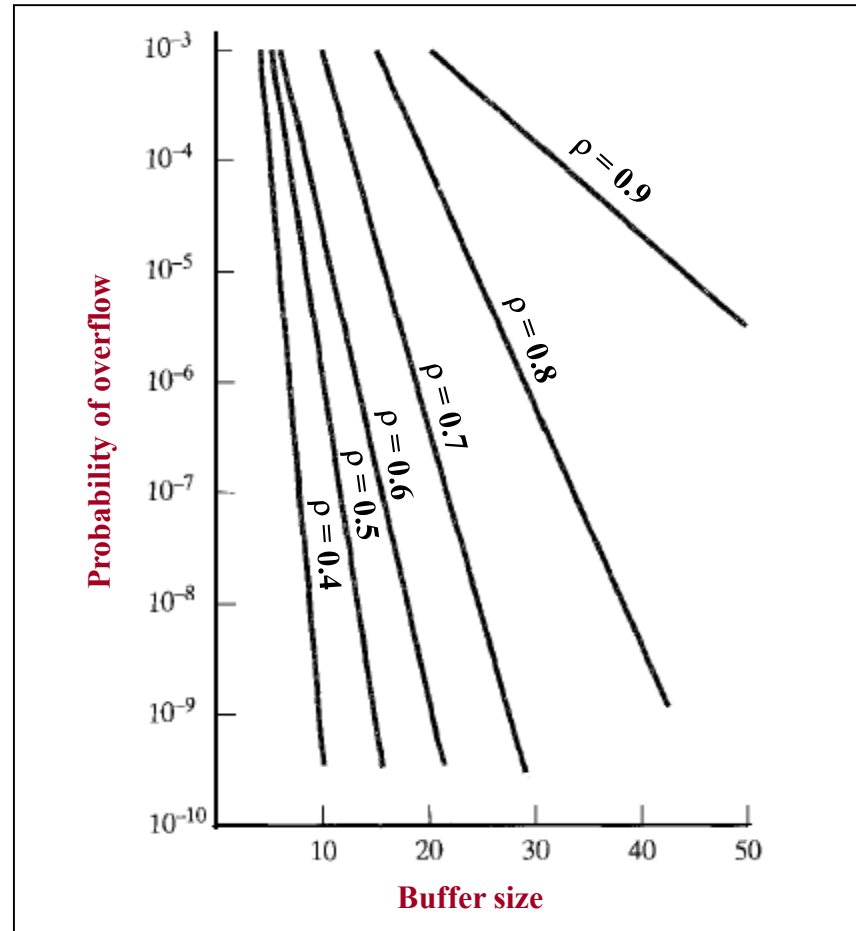

Probability of overflow as a function of buffer size



Cable Modems

- ⌘ dedicate two cable TV channels to data transfer
- ⌘ each channel shared by number of subscribers, using **statistical TDM**
- ⌘ **Downstream**
 - ☑ cable scheduler delivers data in small packets
 - ☑ active subscribers share downstream capacity
 - ☑ **grant requests** to allocate upstream time slots to subscribers
- ⌘ **Upstream**
 - ☑ user **requests timeslots** on shared upstream channel
 - ☑ Headend scheduler notifies subscriber of slots to use



Cable Modem Scheme

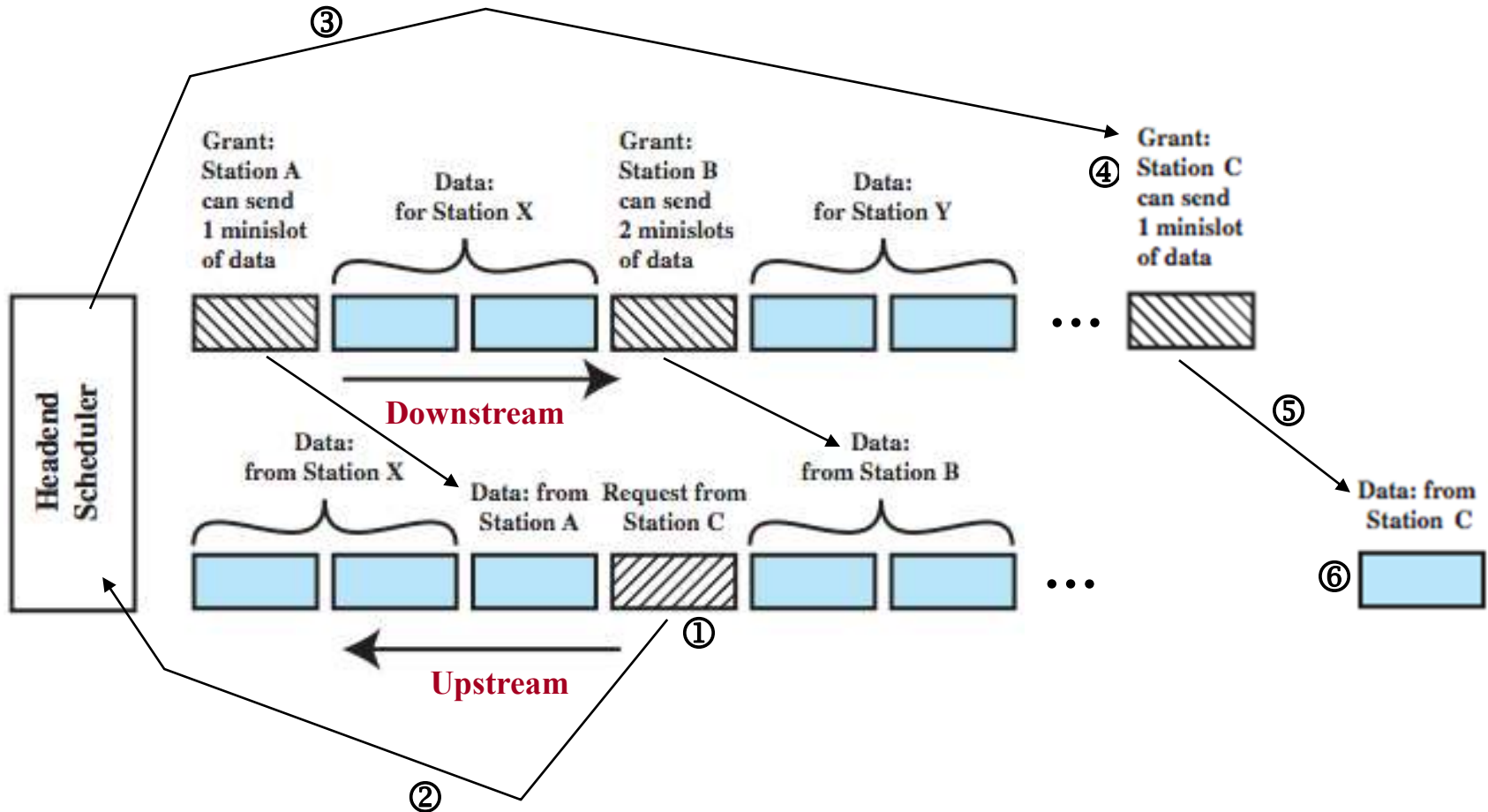

Asymmetrical Digital Subscriber Line (ADSL)

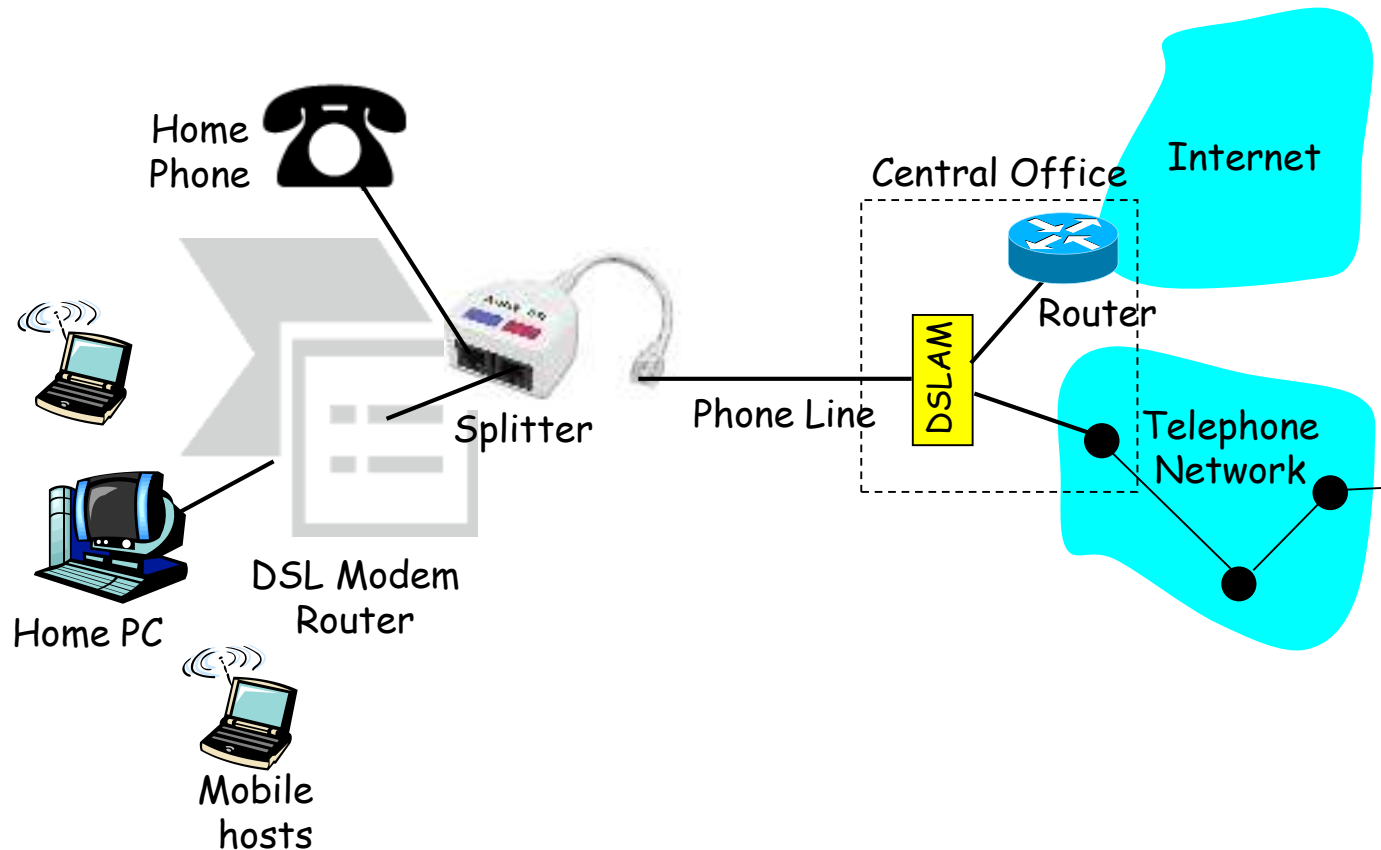

Asymmetrical Digital Subscriber Line (ADSL)

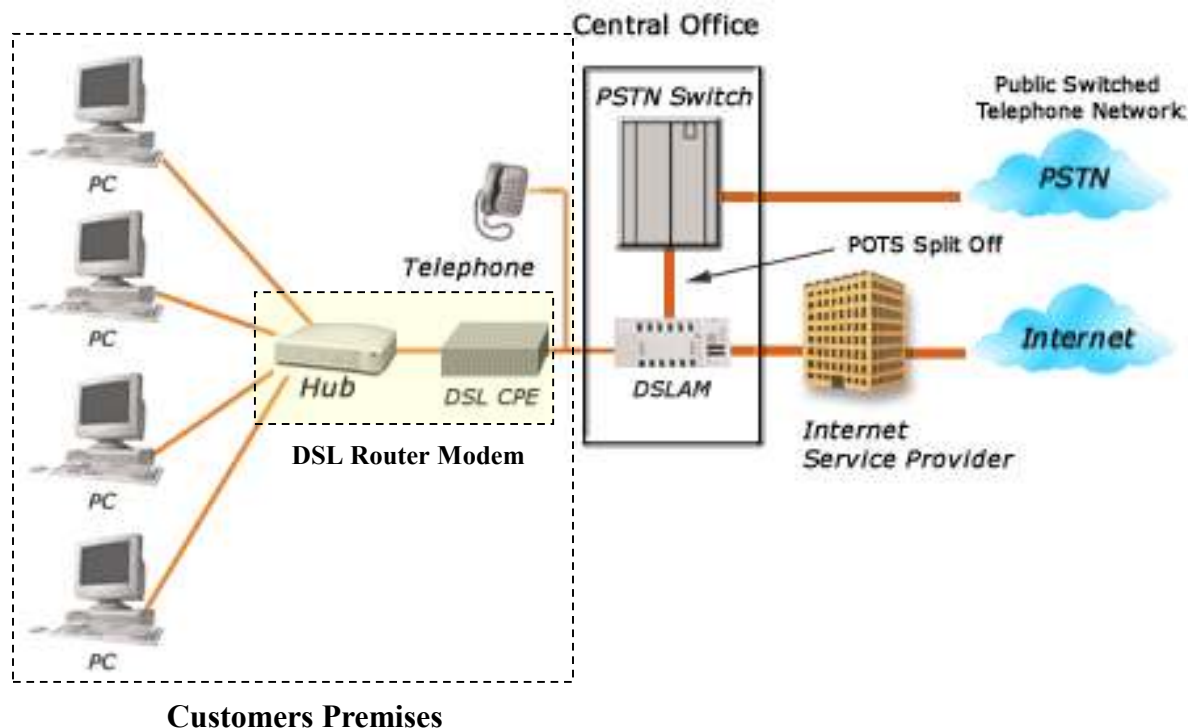

Asymmetrical Digital Subscriber Line (ADSL)

- ⌘ **subscriber line**: link between subscriber and network
- ⌘ carry **voice** grade signal: 0 – 4 kHz
- ⌘ uses currently installed twisted pair cable
 - ☑ support **1 MHz** or more
 - ☑ Provide **high speed data over phone line**
- ⌘ Asymmetric DSL (ADSL)
 - ☑ **more downstream rate than upstream**
 - ☑ **most home user traffic is downstream**
- ⌘ uses Frequency division multiplexing
 - ☑ reserve lowest 25kHz for voice (POTS)
 - ☑ more than 4 kHz to prevent interference
- ⌘ has a range of up to 5.5km

Asymmetrical Digital Subscriber Line (ADSL)

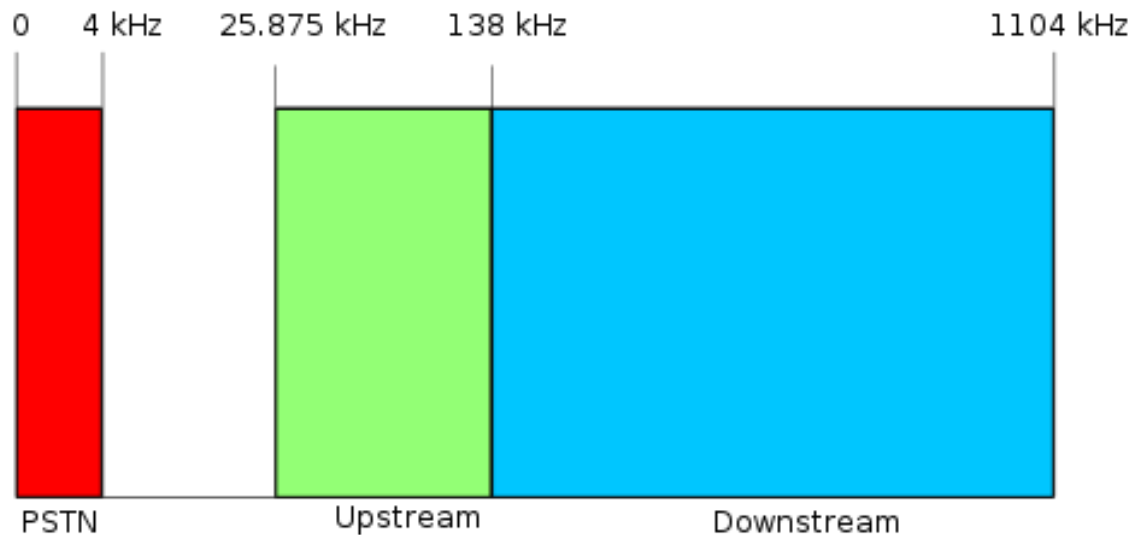

Frequency plan for ADSL. Red area is the frequency range used by normal voice telephony (PSTN), the green (upstream) and blue (downstream) areas are used for ADSL

Discrete Multitone (DMT)

- ⌘ **DMT separates the ADSL signal into 256 subchannels (bins)**
- ⌘ **Transmission band divided to 4.3125 kHz subchannels**
- ⌘ **Each subchannel can carry a data rate up to 60 kbps**
- ⌘ **DMT has 224 downstream frequency bins and up to 26 upstream bins.**
- ⌘ The frequency layout can be summarized as:
 - ⊠ 30Hz-4 kHz, voice.
 - ⊠ 4-25 kHz, unused guard band.
 - ⊠ 25-138 kHz, 26 upstream bins (7-32).
 - ⊠ 138-1104 kHz, 224 downstream bins (33-256).
- ⌘ Typically, a few bins **around 32-33** are not used in order to **prevent interference between upstream and downstream bins** either side of 138 kHz.

http://en.wikipedia.org/wiki/ITU_G.992.1

Discrete Multitone (DMT)

- ⌘ DMT modem sends out **test signals on each subchannel to determine signal-to-noise ratio**
- ⌘ DMT modem then **assigns more bits to channels with better signal transmission qualities and less bits to channels with poorer signal transmission qualities**
- ⌘ typical situation in which there is increasing attenuation and hence decreasing signal-to-noise ratio at higher frequencies
→ **As the higher-frequency subchannels carry less of the load**

Discrete Multitone (DMT)

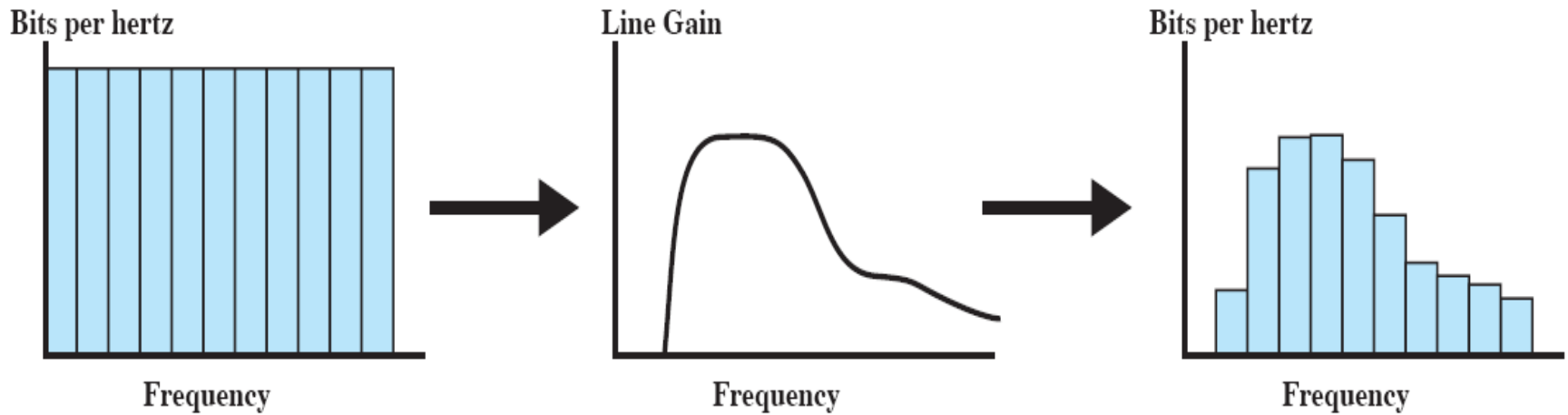

Discrete Multitone (DMT)

- ⌘ Bit stream to be transmitted is **divided into a number of parallel bit streams** (substreams)
- ⌘ **Each substream is carried in separate frequency band using FDM**
- ⌘ Sum of the data rates of the substreams is equal to the total data rate
- ⌘ **Each substream is then converted to an analog signal using QAM**
- ⌘ This scheme works easily because of QAM's ability to assign different numbers of bits per transmitted signal
- ⌘ **Each QAM signal occupies a distinct frequency band, so these signals can be combined by simple addition to produce the composite signal for transmission**

DMT Transmitter

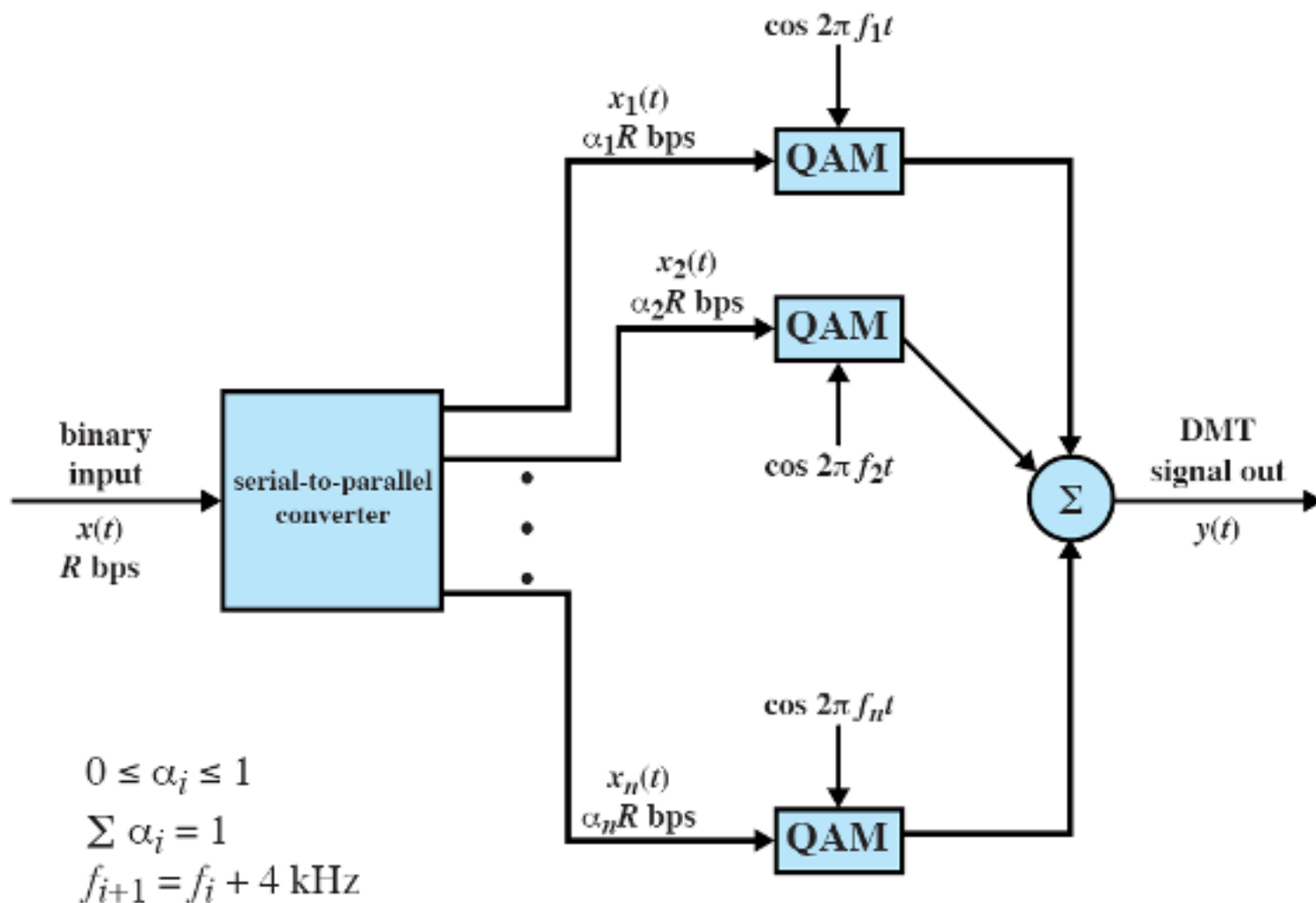



ADSL Standards

Version	Standard name	Common name	Downstream rate	Upstream rate	Approved in
ADSL	ANSI T1.413-1998 Issue 2	ADSL	8.0 Mbit/s	1.0 Mbit/s	1998
ADSL	ITU G.992.1	ADSL (G.DMT)	12.0 Mbit/s	1.3 Mbit/s	1999-07
ADSL	ITU G.992.1 Annex A	ADSL over POTS	12.0 Mbit/s	1.3 Mbit/s	2001
ADSL	ITU G.992.1 Annex B	ADSL over ISDN	12.0 Mbit/s	1.8 Mbit/s	2005
ADSL	ITU G.992.2	ADSL Lite (G.Lite)	1.5 Mbit/s	0.5 Mbit/s	1999-07
ADSL2	ITU G.992.3	ADSL2	12.0 Mbit/s	1.3 Mbit/s	2002-07
ADSL2	ITU G.992.3 Annex J	ADSL2	12.0 Mbit/s	3.5 Mbit/s	
ADSL2	ITU G.992.3 Annex L	RE-ADSL2	5.0 Mbit/s	0.8 Mbit/s	
ADSL2	ITU G.992.4	splitterless ADSL2	1.5 Mbit/s	0.5 Mbit/s	2002-07
ADSL2+	ITU G.992.5	ADSL2+	24.0 Mbit/s	1.3 Mbit/s	2003-05
ADSL2+	ITU G.992.5 Annex M	ADSL2+M	24.0 Mbit/s	3.3 Mbit/s	2008



Saudi Arabia

- ⌘ STC offers ADSL2+ service at maximum of 20 Mbit/s downstream data rate. The service is called Xband Jood and as of 2010 costs SAR 296 per month.
- ⌘ The maximum attainable data rate however depends on the location and is usually less than stated maximum of 20 Mbit/s at most locations.

http://en.wikipedia.org/wiki/ITU_G.992.5



ADSL2+

- ⌘ ADSL2+ extends the capability of basic ADSL by doubling the number of downstream bits. **The data rates can be as high as 24 Mbps downstream and up to 1.4 Mbps upstream** depending on the distance from the DSLAM to the customer's premises.
- ⌘ ADSL2+ is capable of **doubling the frequency band of typical ADSL connections from 1.1 MHz to 2.2 MHz**. This doubles the downstream data rates of the previous ADSL2 standard (which was up to 12 Mbit/s), but like the previous standards will degrade from its peak bit rate after a certain distance.



ADSL2

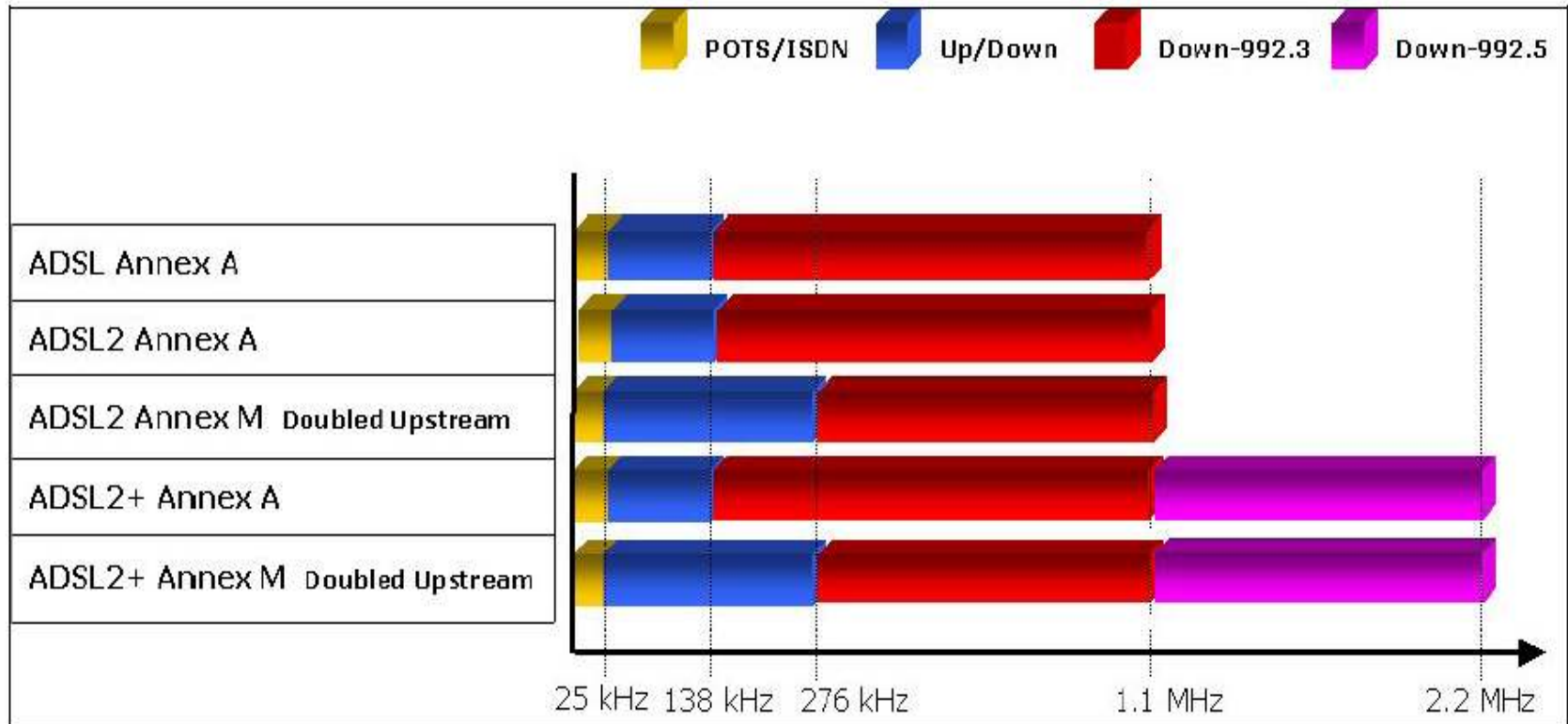

http://www.billion.com/edu/AnnexM_Whitepaper.pdf



xDSL

⌘ High data rate DSL (HDSL)

- ⊞ two-binary, one-quaternary (2B1Q) coding on **dual** twisted pairs
- ⊞ up to 2Mbps over 3.7km

Dibit	Signal level
10	+450 mV
11	+150 mV
01	-150 mV
00	-450 mV

⌘ Single line DSL

- ⊞ 2B1Q coding on **single** twisted pair (residential) with echo cancelling
- ⊞ up to 2Mbps over 3.7km

⌘ Very high data rate DSL

- ⊞ DMT/QAM for very high data rates
- ⊞ over separate bands for separate services



xDSL



	ADSL	HDSL	SDSL	VDSL
Data rate	1.5 to 9 Mbps downstream 16 to 640 kbps upstream	1.544 or 2.048 Mbps	1.544 or 2.048 Mbps	13 to 52 Mbps downstream 1.5 to 2.3 Mbps upstream
Mode	Asymmetric	Symmetric	Symmetric	Asymmetric
Copper pairs	1	2	1	1
Range (24-gauge UTP)	3.7 to 5.5 km	3.7 km	3.0 km	1.4 km
Signaling	Analog	Digital	Digital	Analog
Line code	CAP/DMT	2B1Q	2B1Q	DMT
Frequency	1 to 5 MHz	196 kHz	196 kHz	≥ 10 MHz
Bits/cycle	Varies	4	4	Varies

ADSL = Asymmetric DSL

HDSL = High data rate DSL

SDSL = Single line DSL

VDSL = Very high data rate DSL

Summary

- ⌘ looked at multiplexing multiple channels on a single link
- ⌘ FDM
- ⌘ TDM
- ⌘ Statistical TDM
- ⌘ ADSL and xDSL