

BROADBAND AND HIGH SPEED

Asynchronous Transfer Mode (ATM)

INTRODUCTION

- ❑ **ATM** stands for **A**synchronous **T**ransfer **M**ode
- ❑ ATM is a flexible high bandwidth, low delay network technology that is:
 - ❑ Capable of handling voice, video and data on a single network
- ❑ Major advantages of ATM include:
 - ❑ Bandwidth management capabilities; and
 - ❑ Support for Quality of Service (QoS) features.
- ❑ SONET/SDH was defined for the transport of ATM cells

ATM CONNECTIONS

- ❑ **ATM is a connection oriented technology.**
 - ❑ (A connection must be set up across the ATM network prior to data transfer)
- ❑ **There are two types of ATM connections.**
 - ❑ Virtual path connections – identified by virtual path identifiers (VPI).
 - ❑ Virtual channel connections – identified by a combination of virtual path and circuit identifiers (VPI and VCI).

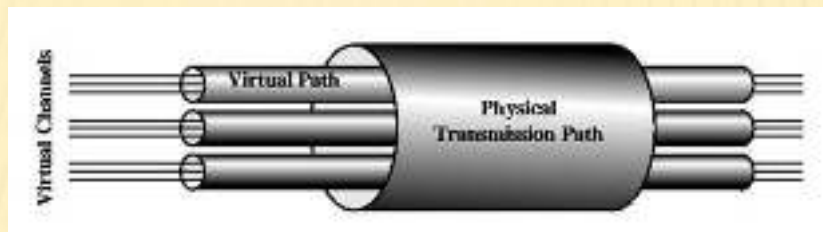

❑ Virtual Channels (VC)

- ❑ The basic unit that carry a stream of ATM cells from one user to another.
- ❑ Identified by a virtual channel identifier.
- ❑ Can be concatenated.
- ❑ Can be configured statically and dynamically.
 - ❑ Statically as PVCs (Permanent Virtual Circuits) that are setup at network configuration time.
 - ❑ Dynamically as SVCs (Switched Virtual Circuits) that are dynamically configured on demand.
- ❑ Can be bundled together into virtual path connections.

❑ Virtual Paths (VP)

- ❑ Contain one or more virtual channels.
- ❑ Identified by a virtual path identifier.
- ❑ Routed through a network as a single entity.
- ❑ Can be used internally for bundling virtual circuits between switches.

ATM SWITCHING

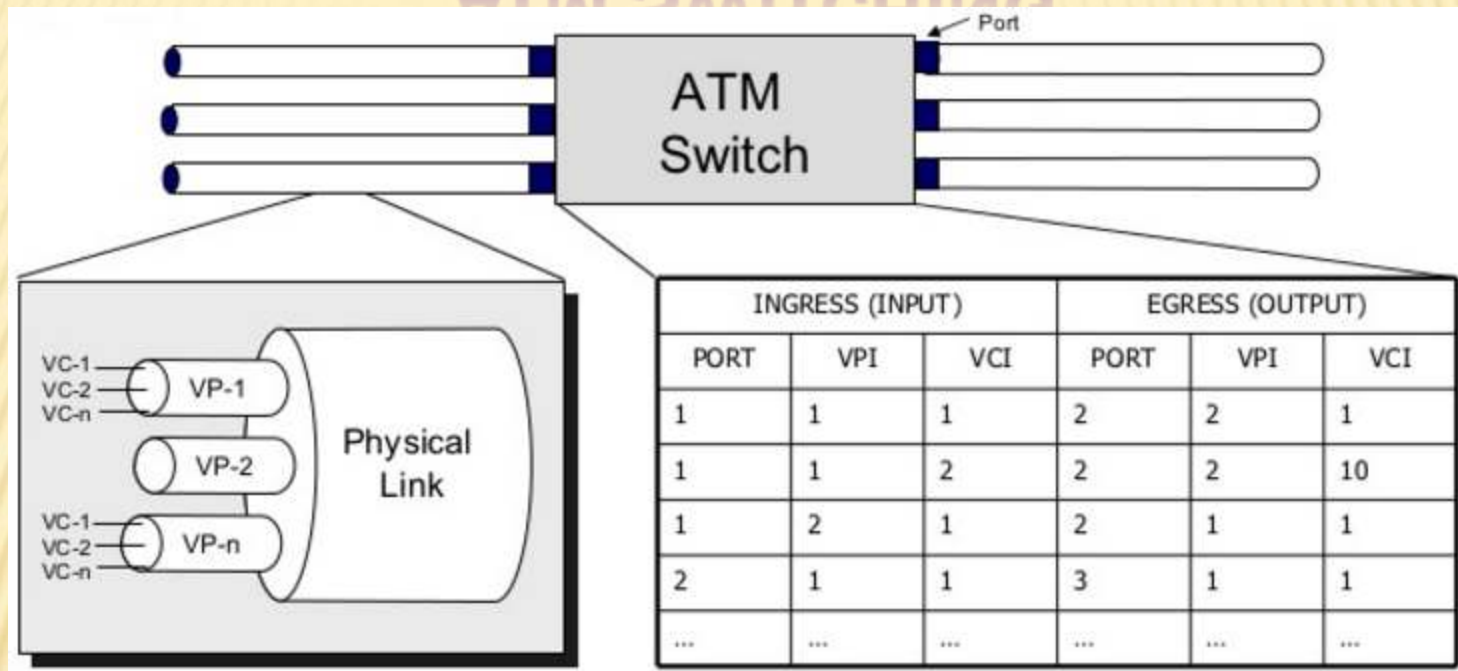

- ❑ ATM switch receives ATM cell from a specific virtual channel on a particular input port.
- ❑ Each ATM cell header contains VPI and VCI information.
- ❑ The combination of port, VPI and VCI is unique within a switch.
- ❑ Switch checks its internal routing table to determine corresponding outgoing VPI and VCI that should be assigned to the cell and the output port on which the cell should be forwarded.
- ❑ The switch replaces the incoming VPI/VCI header info with the outgoing VPI/VCI info and sends the cell through the output port to the next device.
- ❑ The process is repeated across multiple devices until the cell reaches its destination.

ATM CELL STRUCTURE

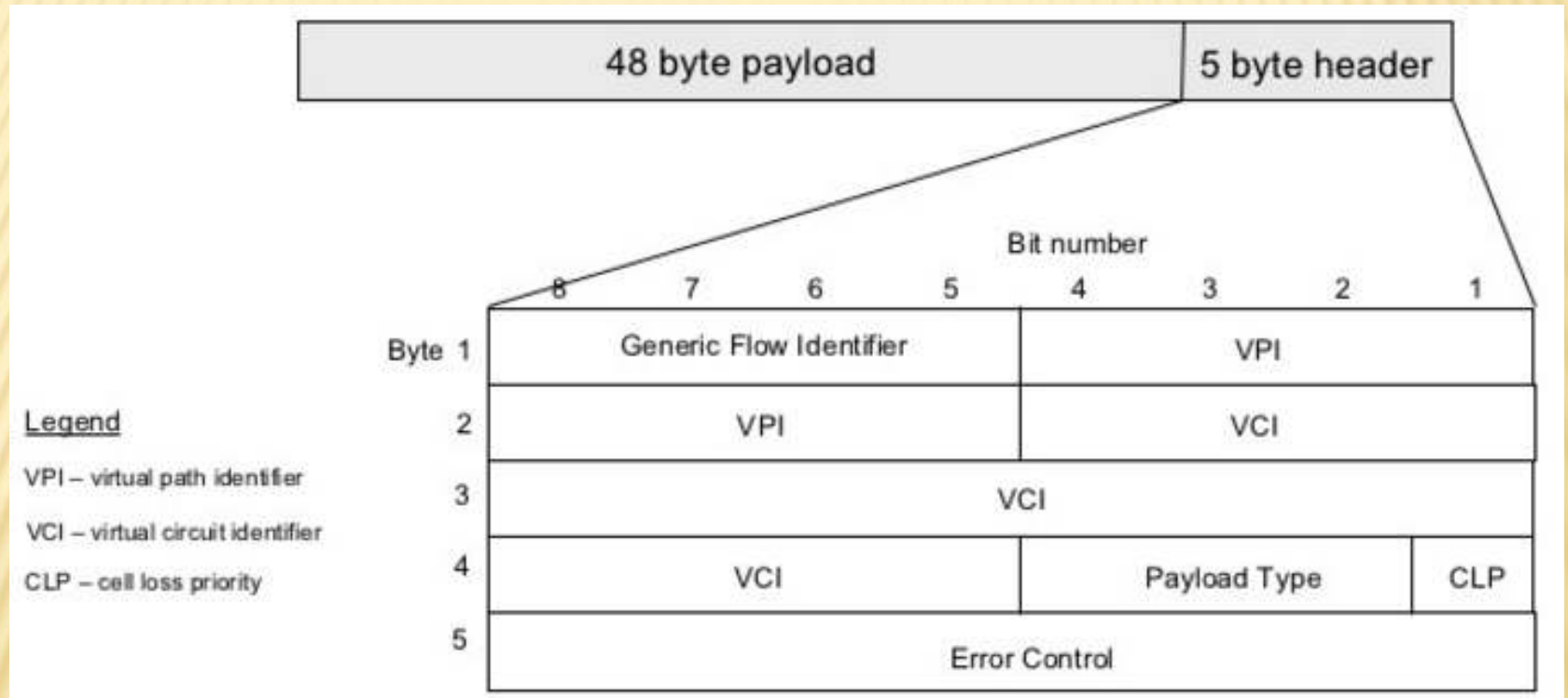

- ❑ Each physical link can support 2^8 virtual paths = 256 VPIs.
- ❑ Each VPI can support 2^{16} virtual circuits = 65,536 VCIs.
- ❑ Each VPI/VCI combination is unique per physical link = 16,777,216 VPI/VCIs.

ATM SYSTEM ARCHITECTURE

- ATM has a layered architecture.
- The ATM layers are :
 - Physical layer – Provides connectivity between network elements (e.g. SONET). Converts to appropriate electrical or optical format.
 - ATM layer – Provides for the transparent transfer of fixed-size (48 octet) data units. Add/Remove 5 byte header to payload.
 - ATM adaptation layer – Enhances the services and performance provided by the ATM layer to meet the needs of higher layer applications. Inserts/extracts information into/from 48 byte payload.
 - Higher layers – Represents various end-user applications (e.g. TCP/IP).

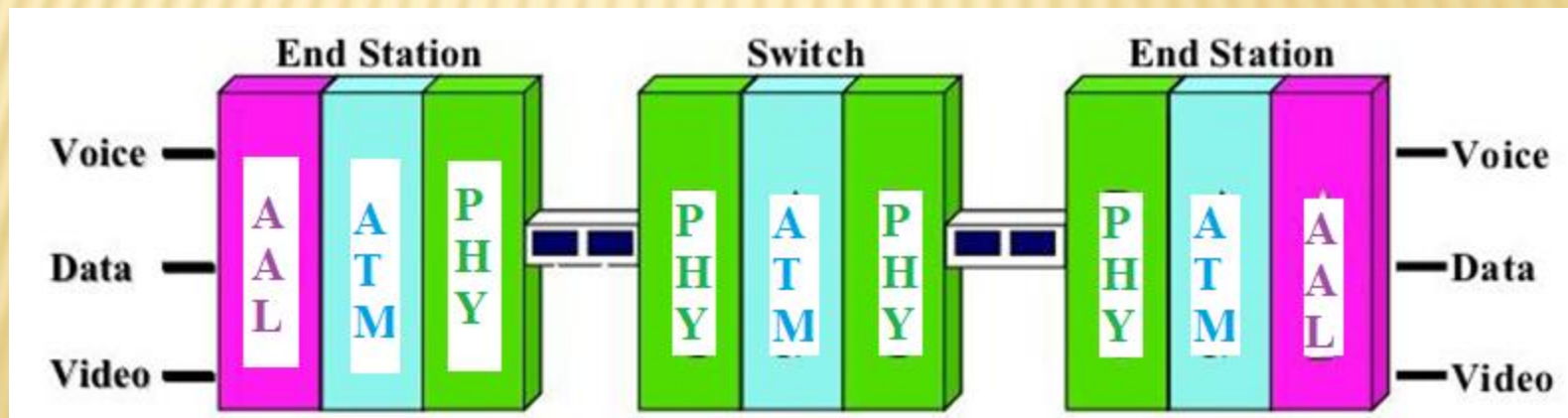

ATM ADAPTATION LAYER (AAL)

- ❑ AAL maps higher-level data onto ATM cells making the data suitable for transport through the ATM network and isolates higher layers from the ATM layer. These functions are performed on the user side.
- ❑ The concept of **Service Classes** is used to define traffic corresponding to specific combinations of:
 - ❑ *Timing relations between source and destination (required/not required).*
 - ❑ *Constant vs. Variable Bit Rate*
 - ❑ *Connection mode (Connection vs. Connectionless Oriented).*
- ❑ Defined Service Classes are :
 - ❑ **Class A-** Synchronous, Connection Oriented, Constant Bit Rate (e.g. DS, DS3 circuit emulation).
 - ❑ **Class B-** Synchronous, Connection Oriented, Variable Bit Rate (e.g. packet video).
 - ❑ **Class C-** Asynchronous, Connection Oriented, Variable Bit Rate (e.g. frame relay).
 - ❑ **Class D-** Asynchronous, Connectionless, Variable Bit Rate (e.g. SMDS).

AAL PROTOCOLS

- ❑ AAL protocols are defined to handle one or more of the above service classes and create properly formatted ATM cells.
 - ❑ AAL type 1 – Meets the needs of class A services.
 - Provides for the acceptance of user info at a fixed rate and delivery of this info at the destination at the same fixed rate and indication of loss or error information.
 - ❑ AAL type 2 – Meets the needs of class B services.
 - Designed to carry low bit rate, variable-length, delay sensitive packets.
 - ❑ AAL type 3/4 – Meets the needs of class C & D services.
 - Designed to carry variable bit rates with no timing relationship.
 - ❑ AAL type 5 – Meets the needs of class C services.
 - Similar to AAL type 3/4 with a simplified information header scheme.

ATM LAYER

□ The ATM Layer :

- Provides services to higher layers (e.g. multiplexing ATM connections on to a single connection) and setting parameters in the ATM cell header (traffic management).
 - Delivers ATM cells to the physical layer for transport.
 - A number of parameters are set at ATM layer that determine quality of service and traffic management
- **Quality of Service (QoS)** : refers to a collection of performance parameters whose values have to do with the speed and accuracy/reliability of ATM connection.
- **Traffic Parameters** : define characteristics of the traffic to be offered over the ATM connection

ATM LAYER

- ❑ Service Categories : represent particular combinations of traffic parameters and QoS parameters. These parameters are determined by users for a connection to meet the needs of higher-level applications.
 - ❑ CBR (Constant Bit Rate) support real-time applications requiring constrained delay variation (voice, video).
 - ❑ RT-VBR (Real Time Variable Bit Rate) support real time applications with bursty traffic.
 - ❑ NRT-VBR (Non-Real Time Variable Bit Rate) support non-real time applications with bursty traffic.
 - ❑ UBR (Unspecified Bit Rate) Represents a “best-effort service” intended for a non-real time applications that don’t require tightly constrained delay or delay variation and are tolerant to cell rate.
 - ❑ ABR (Available Bit Rate) similar to UBR but enhanced to handle applications that require minimum bandwidth requirement.

PHYSICAL LAYER

- ❑ The physical layer is responsible for placing and removing cells from the physical transport medium.
- ❑ Standards for physical interfaces to various media exist.
- ❑ SONET/SDH based transmission media are the most common for transmission of ATM.
- ❑ The physical layer performs two types of functions :
 - ❑ Functions associated with the structure or format of the info to be transmitted and other specific functions (e.g. multiplexing). These functions are independent of the transmission medium.
 - ❑ Functions associated with the transmission of signals over a particular medium (e.g. line coding for a particular medium). These functions are dependent on the transmission medium.

ATM INTERFACES

- ❑ **Private UNI** (user-network interface) – interface between a user's device (e.g. a workstation) and a private ATM switch.
- ❑ **Private NNI** (network-network interface) – interface between private ATM switches needed to support the ATM infrastructure.
- ❑ **Public UNI** – interface between the user's device and a provider of a public ATM service.
- ❑ **Public NNI** – interface between ATM switches in public carrier networks.
 - ❑ Also referred to as B-ISSI (broadband inter-switching system interface) when applied to the connection between two public switches of the same carrier.
 - ❑ Also referred to as B-ICI (broadband inter-carrier interface) when applied to the connection between two carriers networks.

ASYNCHRONOUS TRANSFER MODE (ATM)

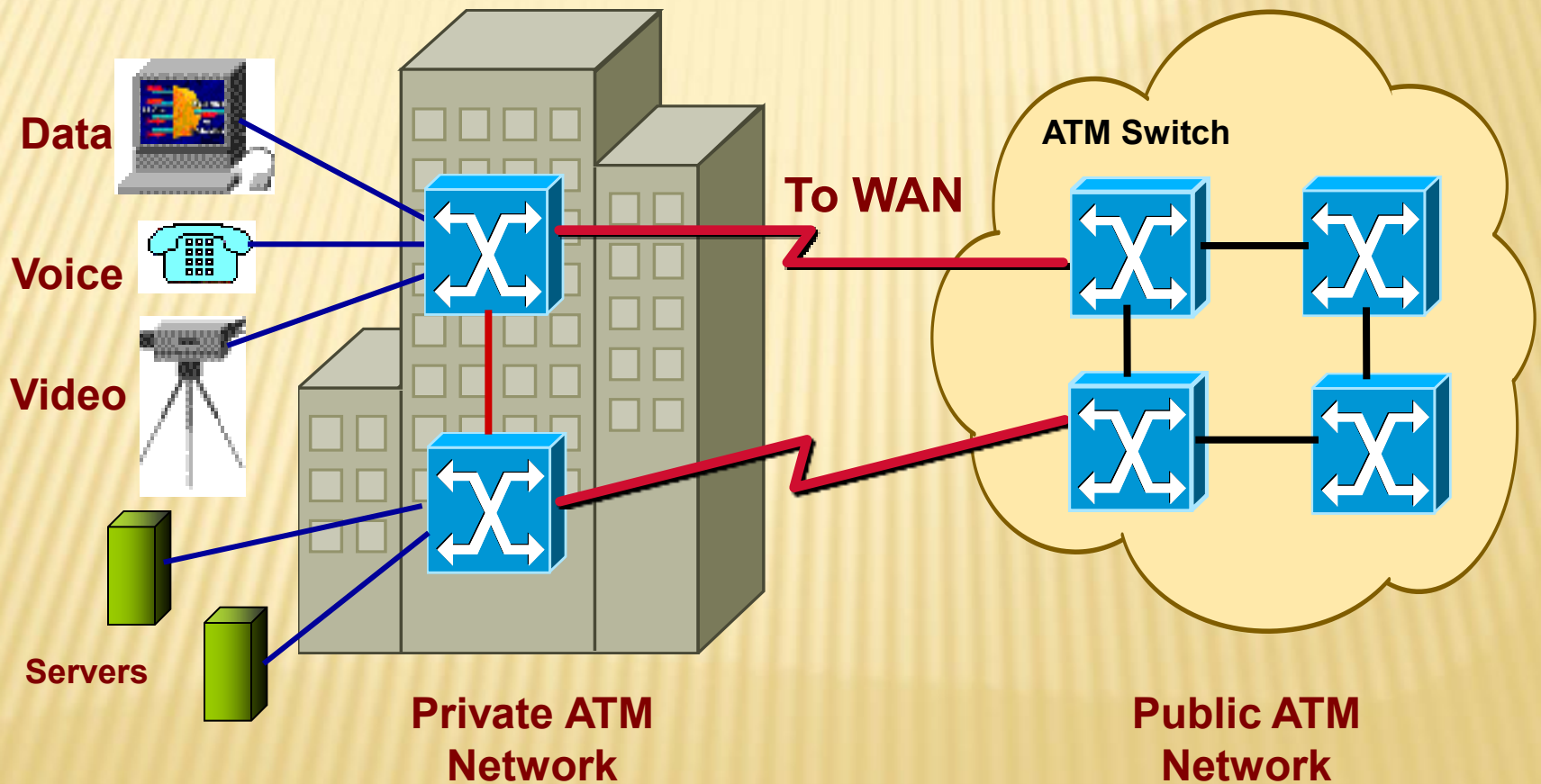

ATM NETWORK INTERFACES

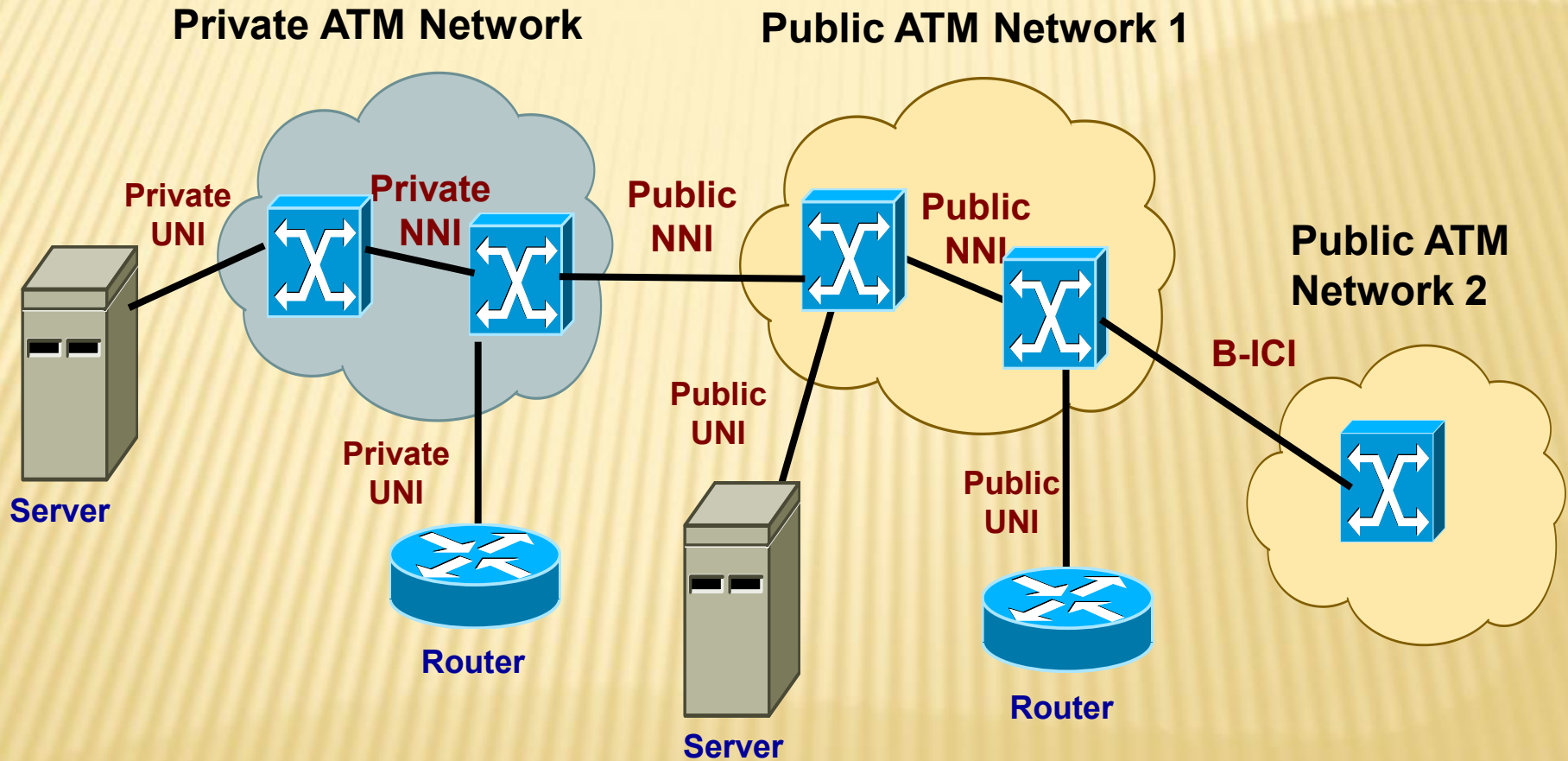

ATM CELL HEADER FORMAT

- ❑ An ATM cell header can be one of two formats:
 - ❑ UNI
 - ❑ NNI
- ❑ **UNI header** is used for communication between ATM endpoints and ATM switches in private ATM networks.
- ❑ **NNI header** is used for communication between ATM switches.
- ❑ Unlike the UNI, the NNI header does not include the **Generic Flow Control (GFC) field**. Additionally, the NNI header has a **Virtual Path Identifier (VPI) field** that occupies the first 12 bits, allowing for larger trunks between public ATM switches.

ATM CELL HEADER FORMAT

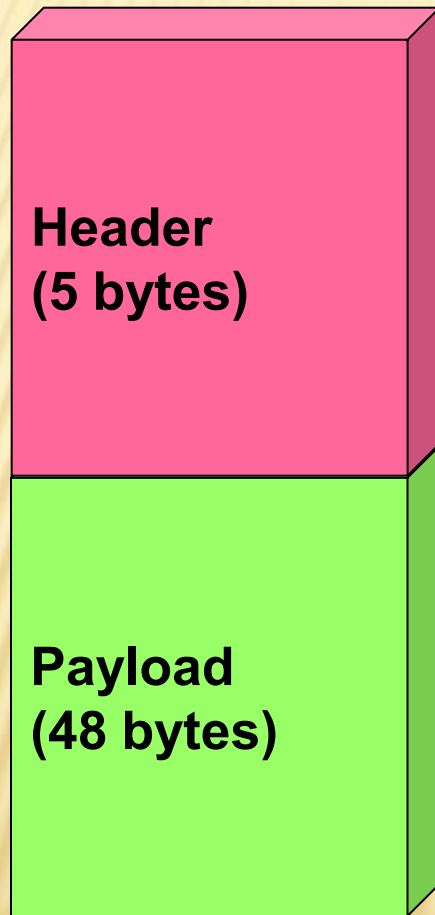

ATM Cell

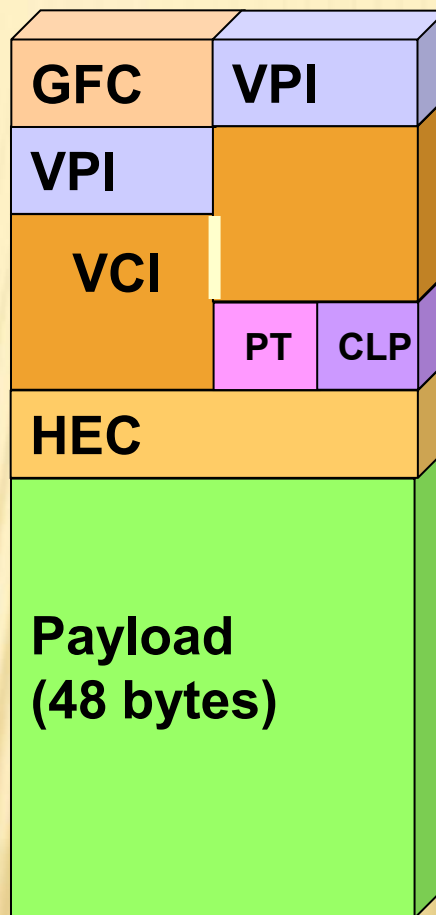

ATM UNI Cell

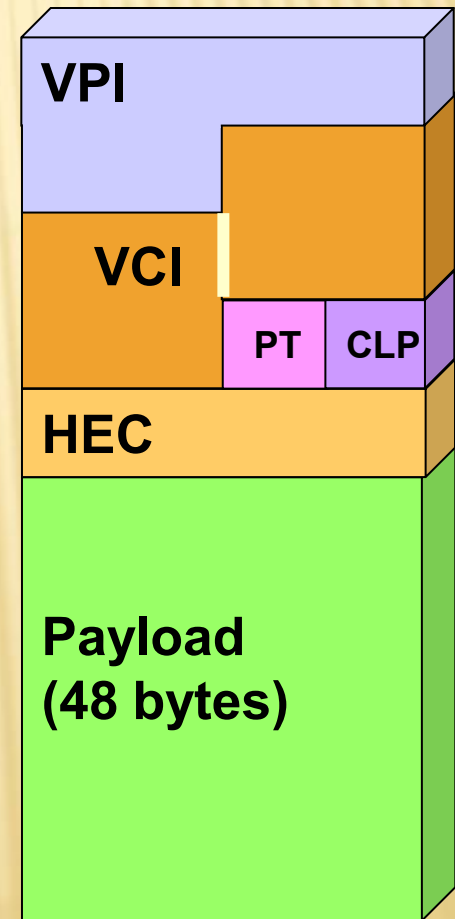

ATM NNI Cell

ATM CELL HEADER FORMAT

- ❑ **Generic Flow Control (GFC)** : It is present only in cells between a host and a network. The purpose of this field was originally conceived as *flow control* or *priority*. However, this field is typically not used and is set to its default value of 0 (binary 0000).
- ❑ **Virtual Path Identifier (VPI)** : It is a integer number selecting particular virtual path.
- ❑ **Virtual Channel Identifier (VCI)** : It is a integer number selecting particular virtual circuit within the chosen virtual path.
 - ❑ Since the *VPI* field has 8 bits (at the UNI) and the *VCI* field has 16 bits, theoretically, a host could have up to 256 VC bundles, each containing up to 65,536 virtual circuits. Actually, some *VCI* are reserved for control functions.
 - ❑ *VPI/VCI*, identifies the next destination of a cell as it passes through a series of ATM switches on the way to its destination.
- ❑ **Payload Type (PT)** : Indicates in the *first bit* whether the cell contains user data or control data. If the cell contains user data, the bit is set to 0. If it contains control data, it is set to 1. The *second bit* indicates congestion (0 = no congestion, 1 = congestion), and the *third bit* has a open purpose.

ATM CELL HEADER FORMAT

Payload Type	Meaning
000	User data cell, no congestion, cell type 0
001	User data cell, no congestion, cell type 1
010	User data cell, congestion experienced, cell type 0
011	User data cell, congestion experienced, cell type 1
100	Maintenance information between adjacent switches
101	Maintenance information between source and destination switches
110	Resource Management cell (used for ABR congestion control)
111	Reserve for future function

ATM CELL HEADER FORMAT

- ❑ **Cell Loss Priority (CLP)** : Indicates whether the cell should be discarded if it encounters extreme congestion as it moves through the network. **If the CLP bit equals 1, the cell should be discarded in preference to cells with the CLP bit equal to 0.**
 - ❑ The CLP bit can be set by the host to differentiate between high priority traffic and low priority traffic.
 - ❑ If congestion occurs and cells must be discarded, **switches discard cells with CLP set to 1.**
- ❑ **Header Error Control (HEC)** : Calculates checksum only on the first 4 bytes of the header. It does not check the payload.
 - ❑ **HEC** can correct all single bit error in these 4 bytes, and can detect about 90% of all multi-bit errors. thereby preserving the cell rather than discarding it.

ATM SERVICES

- ❑ The available ATM services are:
 - *Permanent virtual circuits (PVC)*
 - *Switched virtual circuits (SVC)*

- ❑ **PVC** allows direct connectivity between sites [similar to a leased line].
 - ❑ **Advantages** : PVC guarantees availability of a connection and does not require call setup procedures between switches.
 - ❑ **Disadvantages** : Static connectivity and manual setup. Each piece of equipment between the source and the destination must be manually provisioned for the PVC.

- ❑ **SVC** is created and released dynamically and remains in use only as long as data is being transferred [similar to a telephone call]. Dynamic call control requires a signaling protocol between the ATM endpoint and the ATM switch.
 - ❑ **Advantages** : Connection flexibility and call setup that can be handled automatically by a networking device.
 - ❑ **Disadvantages** : The extra time and overhead required to set up the connection.

SVC [Q.2931] CONNECTION

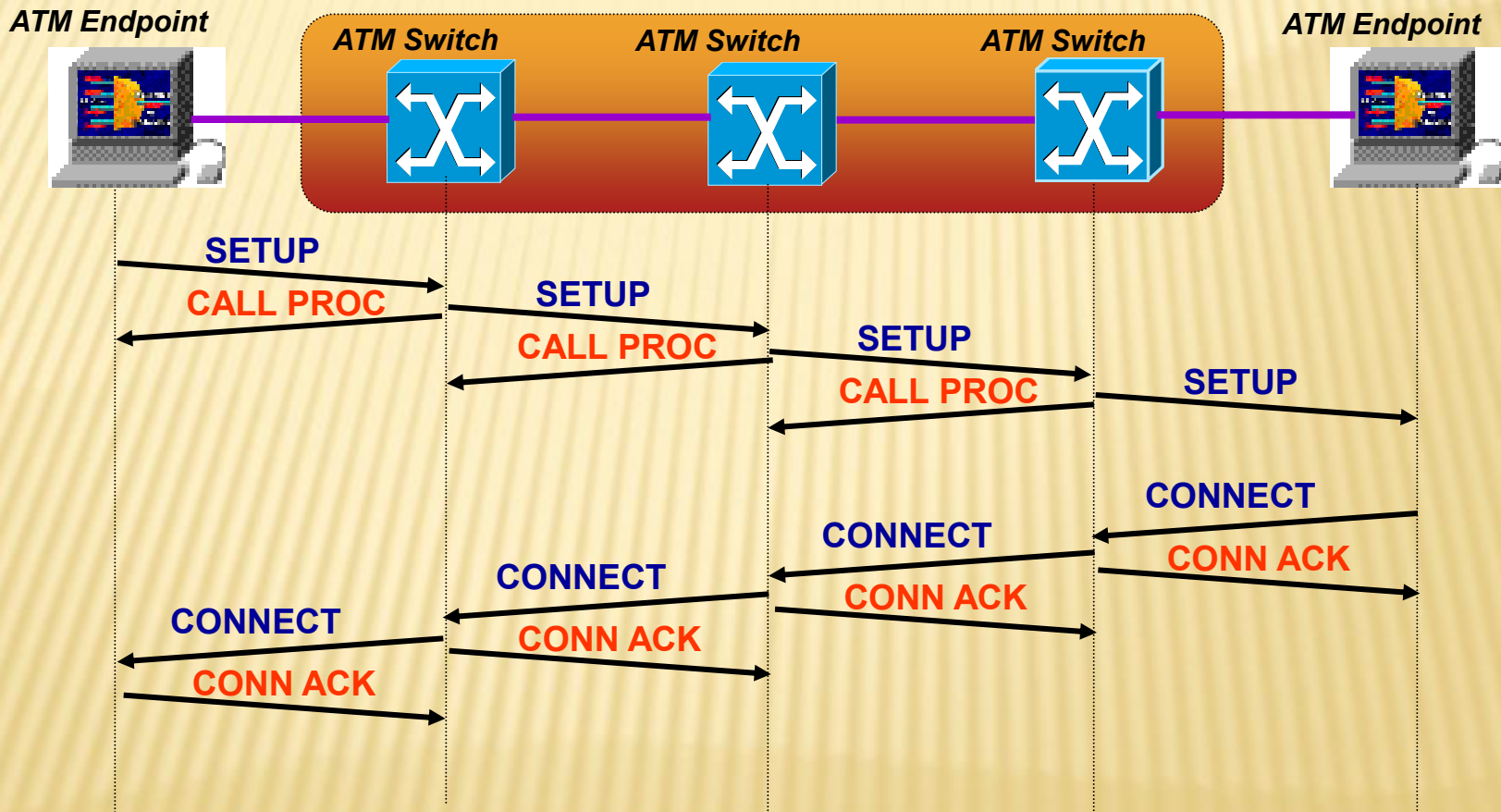

SVC [Q.2931] TERMINATION

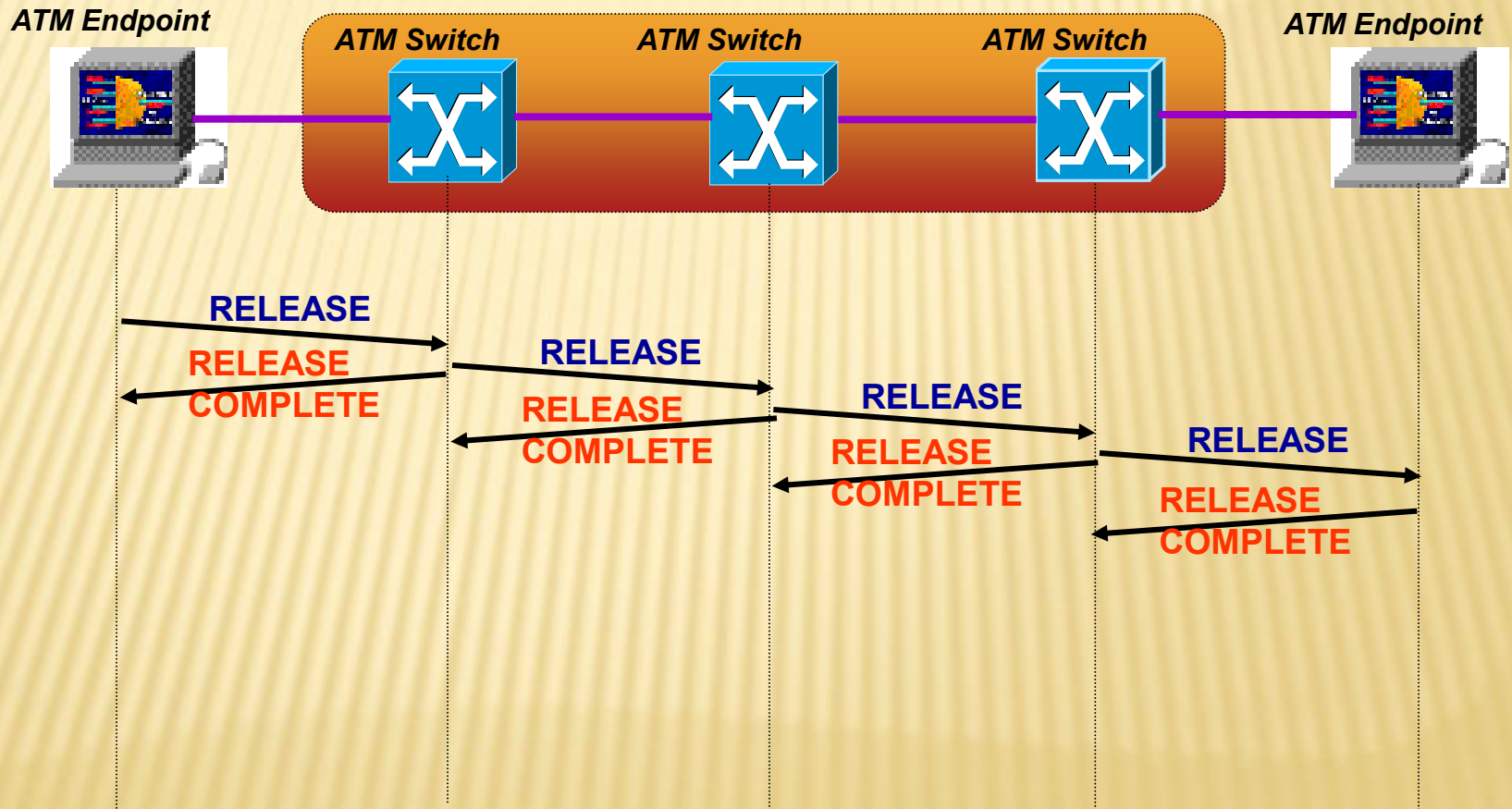

ATM SWITCHES

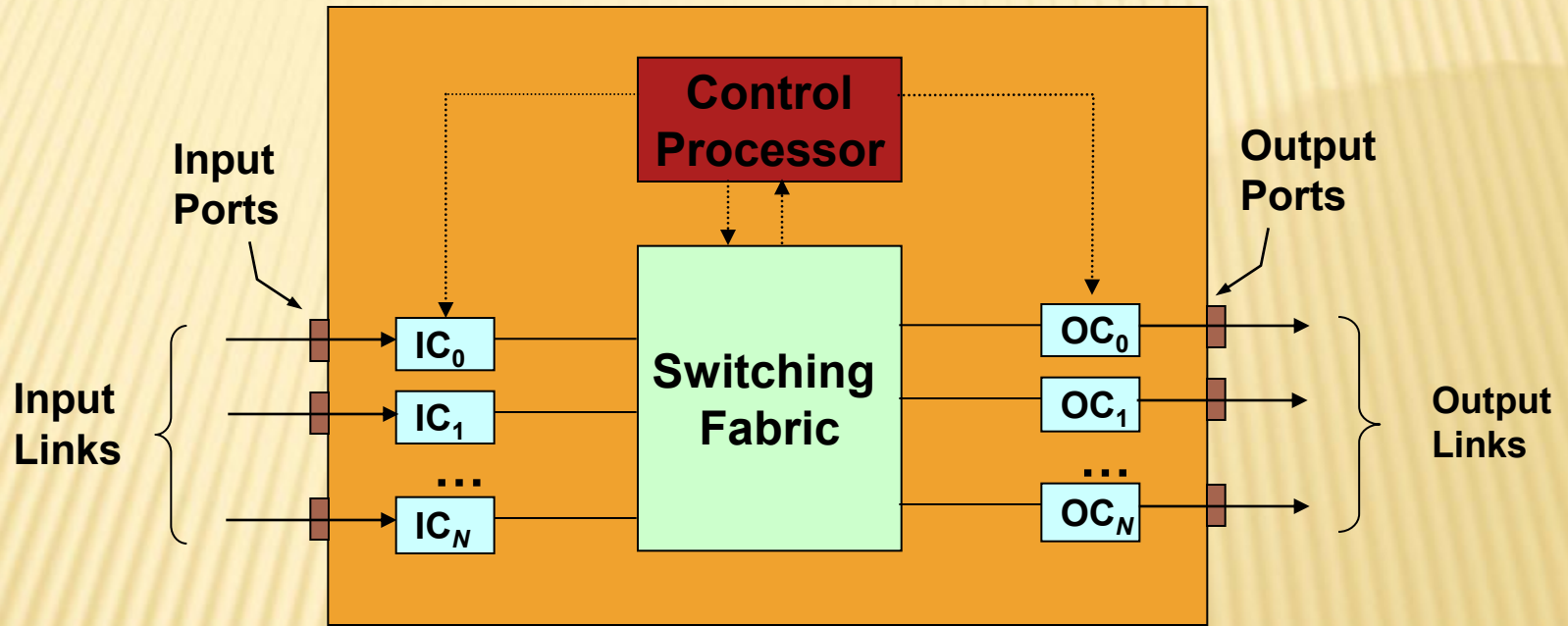

IC = Input Controller

OC = Output Controller

ATM SWITCHES – THE BANYAN SWITCH

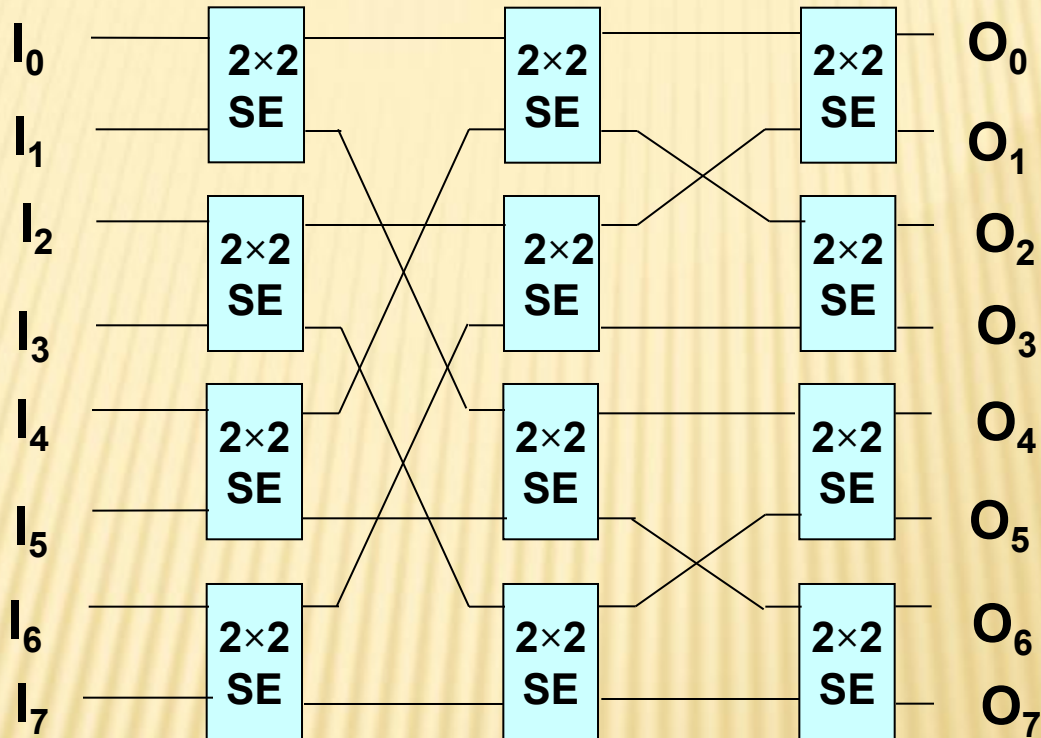

ATM SWITCHES – THE BATCHER-BANYAN SWITCH

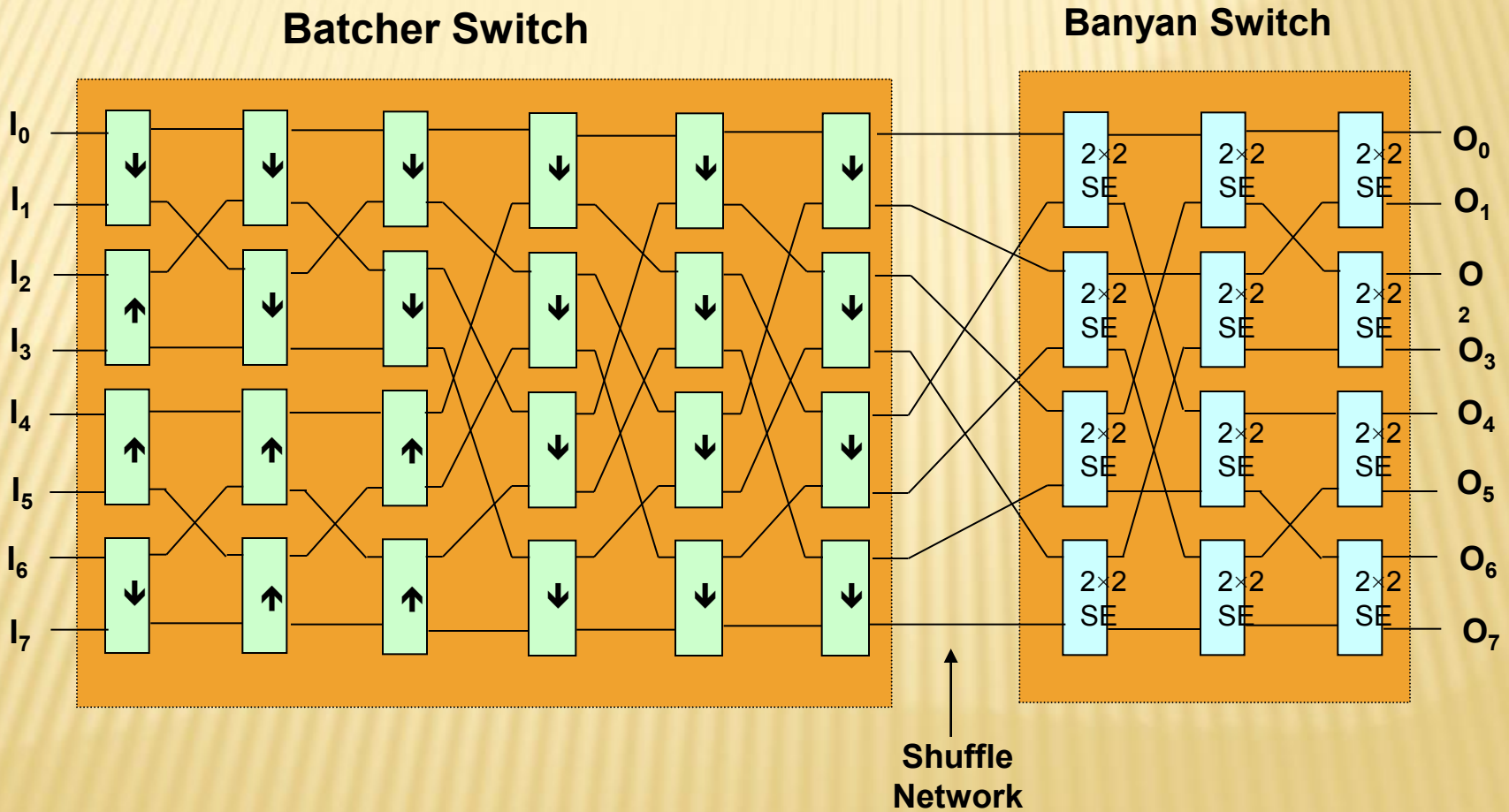

ATM SWITCHES

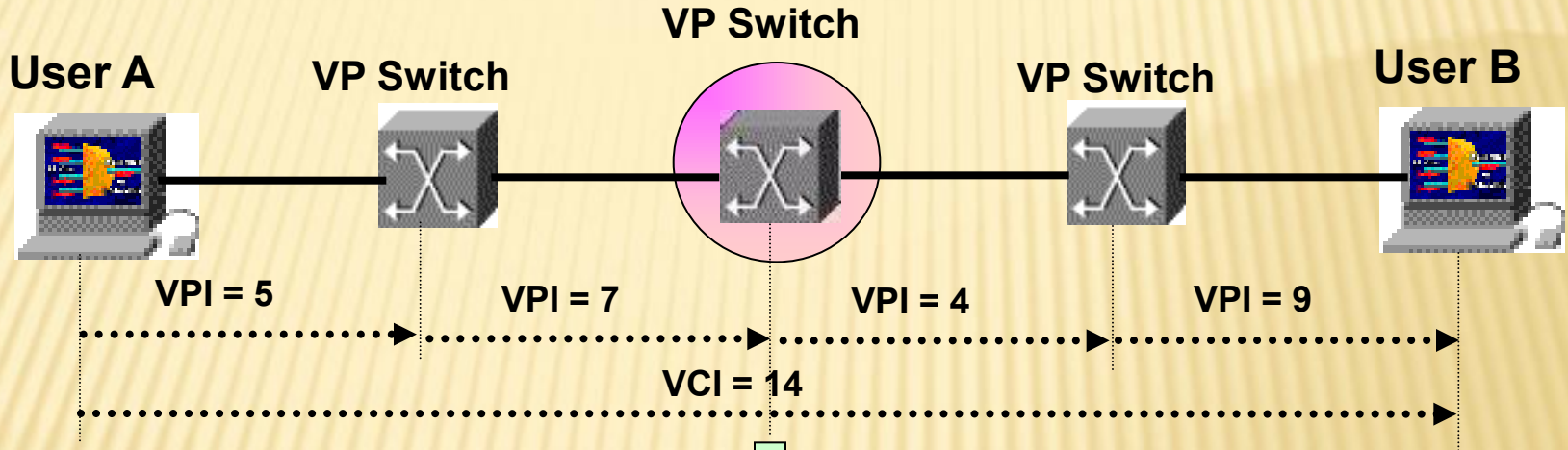

VPI Translation

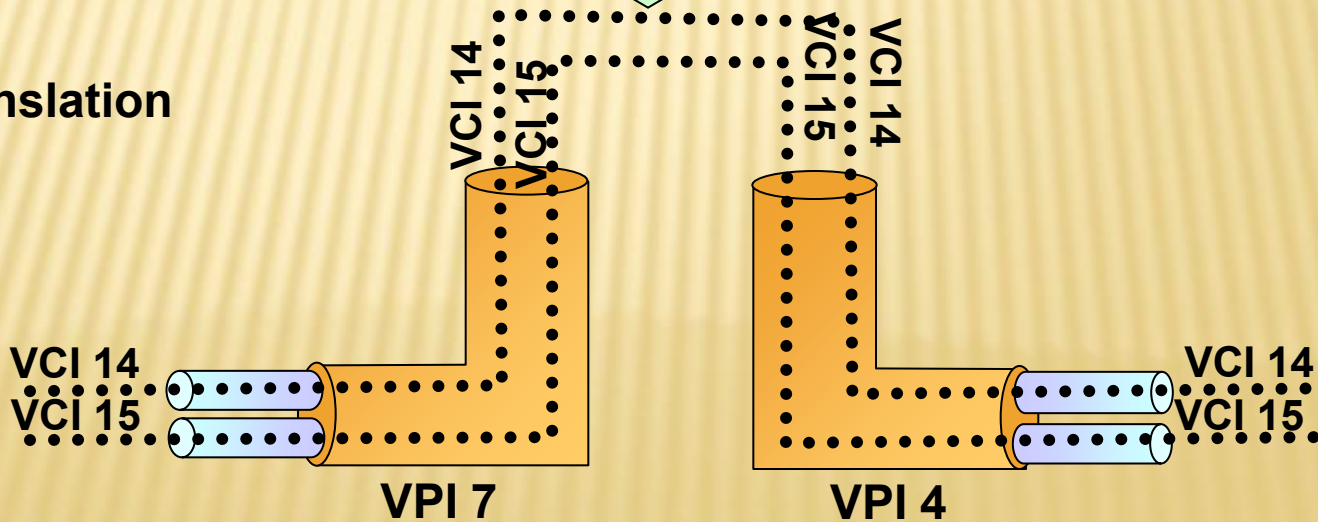

ATM SWITCHES

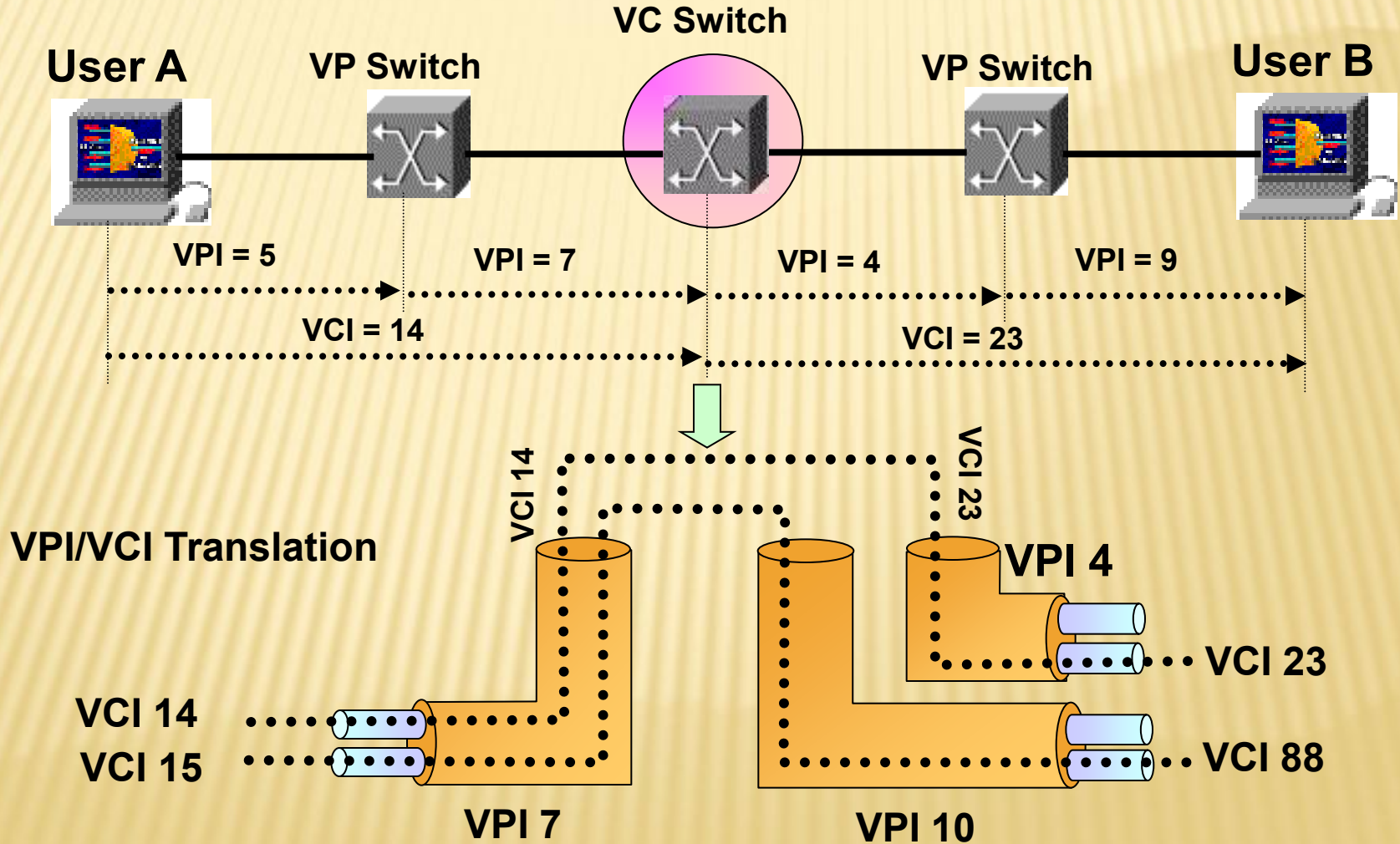

ATM SWITCHES: VPI TRANSLATION

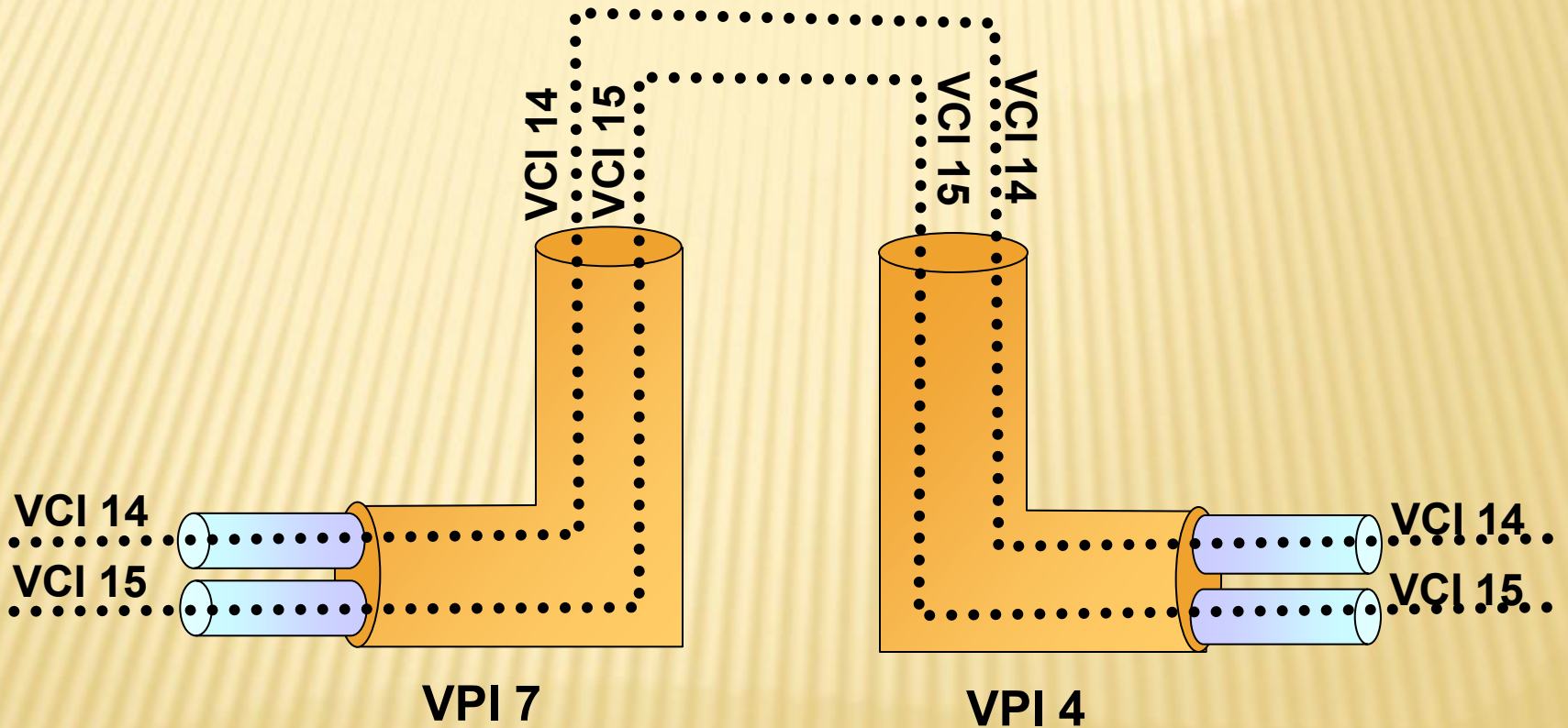

ATM SWITCHES: VPI/VCI TRANSLATION

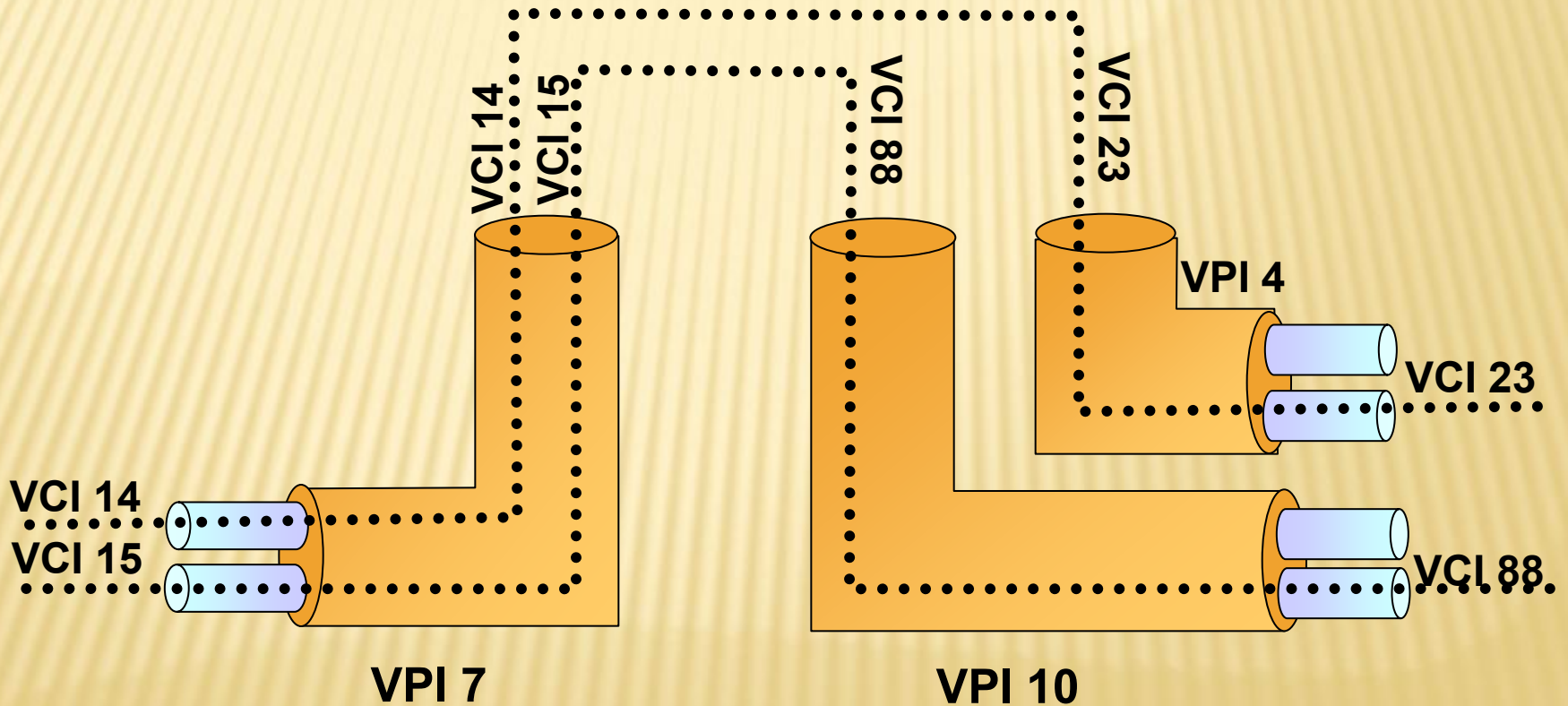

ATM SWITCHING OPERATIONS

- ❑ The *basic operation* of an ATM switch is straightforward:
 - ❑ The cell is received across a link on a known *VCI* or *VPI* value.
 - ❑ The switch looks up the connection value in a *local translation table* to determine the outgoing port (or ports) of the connection and the new *VPI/VCI* value of the connection on that link.
 - ❑ The switch then retransmits the cell on that outgoing link with the appropriate connection identifiers.
 - ❑ Because all *VCIs* and *VPIs* have *only local significance* across a particular link, these values are remapped, as necessary, at each switch.

ATM SERVICE CATEGORIES

- ❑ **Service Categories** : represent particular combinations of traffic parameters and QoS parameters. These parameters are determined by users for a connection to meet the needs of higher-level applications.
 - ❑ **CBR (Constant Bit Rate)** support real-time applications requiring constrained delay variation (**voice, video**).
 - ❑ **RT-VBR (Real Time Variable Bit Rate)** support real time applications with bursty traffic (e.g., **video conferencing**).
 - ❑ **NRT-VBR (Non-Real Time Variable Bit Rate)** support non-real time applications with bursty traffic (e.g., **multimedia email**).
 - ❑ **UBR (Unspecified Bit Rate)** Represents a “best-effort service” intended for a non-real time applications that don’t require tightly constrained delay or delay variation and are tolerant to cell rate (**no feedback to the sender when the congestion occurs**).
 - ❑ **ABR (Available Bit Rate)** similar to UBR but enhanced to handle applications that require minimum bandwidth requirement (**feedback to the sender when the congestion occurs**).

ATM SERVICE CATEGORIES

Class	Description	Example
CBR	Constant bit rate	T1 circuit
RT-VBR	Variable bit rate: real time	Real-time Videoconferencing
NRT-VBR	Variable bit rate: non-real time	Multimedia Email
ABR	Available bit rate	Browsing the Web
UBR	Unspecified bit rate	Background file transfer

SERVICE CATEGORIES

Service Characteristic	CBR	RT-VBR	NRT-VBR	ABR	UBR
Bandwidth guarantee	Constant	Average	Average	Minimum	None
Suitable for real-time traffic	Yes	Yes	No	No	No
Suitable for bursty traffic	No	YES	Yes	Yes	Yes
Feedback about congestion	No	No	No	Yes	No

AAL CLASSES OF TRAFFIC

Class A	Constant bit rate (CBR)
	Connection-oriented, e.g., CBR for video
	Timing relationship between source and destination: Required
Class B	Variable bit rate (VBR)
	Connection-oriented, e.g., VBR for video or voice
	Timing relationship between source and destination: Required
Class C	Variable bit rate (VBR)
	Connection-oriented, e.g., bursty data services
	Timing relationship between source and destination: Not required
Class D	Variable bit rate (VBR)
	Connectionless, e.g., bursty datagram services
	Timing relationship between source and destination: Not required
Class X	Traffic type and timing requirements defined by the user

AAL CLASSES OF TRAFFIC

Class	A	B	C	D
Timing	Synchronous		Asynchronous	
Bit transfer	Constant	Variable		
Connection mode	Connection-oriented			Connectionless

ATM CONNECTIONS

- ✘ ATM supports two types of connections:
 - + *Point-to-point*
 - + *Point-to-multipoint*

ATM CONNECTIONS

- ✘ **Point-to-point** connects two ATM end systems and can be *unidirectional* (one-way communication) or *bidirectional* (two-way communication).
- ✘ **Point-to-multipoint** connects a single-source end system (known as the root node) to multiple destination end systems (known as leaves). Such connections are unidirectional only. Root nodes can transmit to leaves, but leaves cannot transmit to the root or to each other on the same connection. Cell replication is *done within the ATM network by the ATM switches* where the connection splits into two or more branches.

ATM QUALITY OF SERVICE

- × ATM supports:
 - + *Traffic contract*
 - + *Traffic shaping*
 - + *Traffic policing*

ATM QUALITY OF SERVICE—TRAFFIC CONTRACT

- ❑ When a virtual circuit is established, both *the transport layer in the host machine* and *the network* must agree on a *contract* defining the service.
- ❑ A **traffic contract** specifies the intended data flow.
- ❑ When an *ATM end system* connects to an *ATM network*, it enters a contract with the network, based on *QoS parameters*.
- ❑ The *contract* between the customer and the network depends on :
 - ❑ *The traffic to be offered (traffic descriptor).*
 - ❑ *The service agreed upon (quality of service desired by the customer and accepted by the network).*
- ❑ The contract may be *different* for each direction.

ATM QUALITY OF SERVICE—TRAFFIC CONTRACT

❑ Peak Cell Rate (PCR):

- ❑ *PCR* is the maximum rate at which the sender is planning to send cells.
- ❑ If a cell is sent every 4 μ sec at minimum, its *PCR* is 250,000 cells/sec.

❑ Sustained Cell Rate (SCR):

- ❑ *SCR* is the expected cell rate averaged over a long time interval.
- ❑ For *CBR*, *SCR* will be equal to *PCR*, but for all the other service categories, it will be substantially lower.

❑ Minimum Cell Rate (MCR):

- ❑ *MCR* is the minimum number of cells/sec that the customer considers acceptable.
- ❑ When *ABR* service is requested, then the actual bandwidth used must lie between *MCR* and *PCR*.
- ❑ If the customer and the network agree to set *MCR* to 0, then *ABR* service becomes similar to *UBR* service.

❑ Cell Variation Delay Tolerance (CVDT):

- ❑ *CVDT* tells how much *variation* will be present in cell transmission times.

-
- ❑ The following *QoS parameters* describe characteristics of the network and are measured at the receiver.
 - ❑ **Cell Loss Ratio (CLR)** is the fraction of the transmitted cells that lost or are delivered too late.
 - ❑ **Cell Transfer Delay (CTD)** is the average transit time from the source to destination.
 - ❑ **Cell Delay Variation (CDV)** measures how uniformly the cells are delivered.
 - ❑ **Cell Error Ratio (CER)** is the fraction of the cells that are delivered with one or more bits wrong.
 - ❑ **Severely-Errored Cell Block Ratio (SECBR)** is the fraction of N-cell blocks of which M or more cells contain an error
 - ❑ **Cell Miss-insertion Rate (CMR)** is the number of cells/sec that are delivered to the wrong destination because of an undetected error in the header.

ATM QUALITY OF SERVICE—TRAFFIC CONTRACT

Parameter	Acronym	Meaning
Peak Cell Rate	PCR	Maximum rate at which cells will be sent
Sustained Cell Rate	SCR	The long-term average cell rate
Minimum Cell Rate	MCR	The minimum acceptable cell rate
Cell Delay Variation Tolerance	CDVT	The maximum acceptable cell cell jitter
Cell Loss Ratio	CLR	Fraction of cells lost or delivered too late
Cell Transfer Delay	CTD	Average transit time from source to destination
Cell Delay Variation	CDV	The variance in cell delivery times
Cell Error Ratio	CER	Fraction of cells delivered with error
Severely-Errored Cell Block Ratio	SECBR	Fraction of blocks garbled
Cell Miss-insertion Rate	CMR	Fraction of cells delivered to wrong destination

ATM QUALITY OF SERVICE —TRAFFIC SHAPING

- **Traffic shaping** is the use of queues to constrain data bursts, limit peak data rate, and smooth jitters so that traffic will fit within the promised envelope. **ATM devices are responsible for adhering to the contract by means of traffic shaping.**

ATM QUALITY OF SERVICE —TRAFFIC POLICING

- ✘ ATM switches can use **traffic policing** to enforce the contract.
- ✘ The switch can measure the actual traffic flow and compare it against the agreed-upon traffic envelope. If the **switch finds that traffic is outside of the agreed-upon parameters, it can set the cell-loss priority (CLP) bit of the offending cells.**
- ✘ Setting the *CLP* bit makes the cell *discard eligible*, which means that any **switch handling the cell is allowed to drop the cell during periods of congestion.**

ATM LAYERS

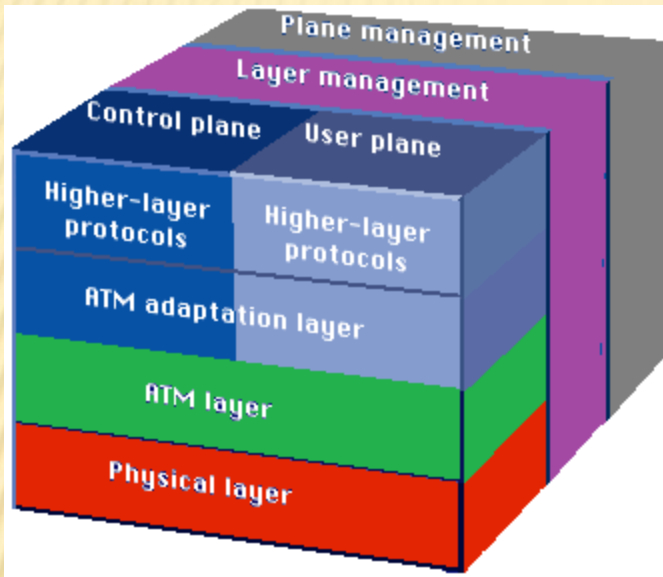

The function and associated information of the planes is as follows:

Plane	Function	Information flow
User	Transfer of user application data	User application
Control	Call and connection control	Signalling related to calls and connections
Management (layer / plane management)	Network supervision	Network status and performance

- The ATM reference model is composed of the following *planes*:
 - ❖ **Control Plane** manages the call and connection.
 - ❖ **User Plane** manages the transfer of data, flow control, and error control.
 - ❖ **Management Plane** : This plane contains two components:
 - **Layer management** manages functions, such as the detection of failures and protocol problems.
 - **Plane management** manages and coordinates functions related to the complete system.

ATM LAYER FUNCTIONS

The higher layers

The user services are supported in these layers. Four classes of service have been identified:

Class A connection oriented constant bit rate, e.g. speech

Class B connection oriented with timing between the source and destination, e.g. video

Class C connection oriented without timing, e.g. data

Class D connectionless, e.g. data from LANs and MANs

The ATM adaption layer

The AAL converts application data into ATM data units in order to provide support for user applications. All AAL functions are performed at the edges of the network, and all AAL information is carried within the ATM cell information fields transparently by the ATM layer.

The ATM layer

This layer takes and returns data from the AAL and generates and interprets the cells respectively. The layer transports the data according to the protocol information in the cell headers transparently.

The physical layer

This is the lowest level layer, and it is responsible for the transmission of ATM cells as bit streams across a physical medium.

ATM REFERENCE MODEL

OSI Reference Model

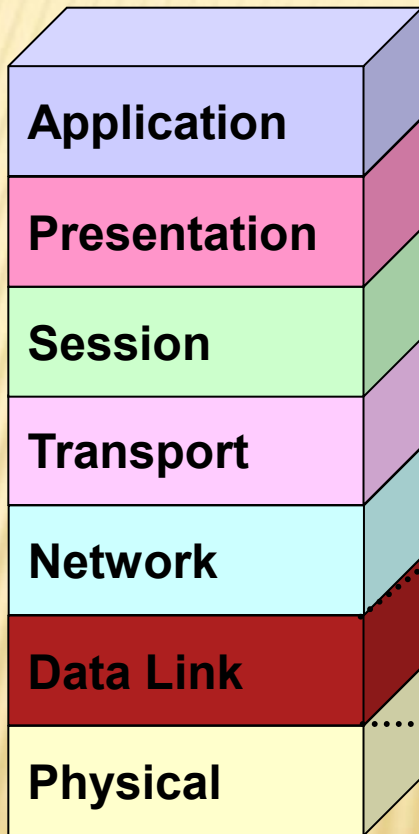

ATM Reference Model

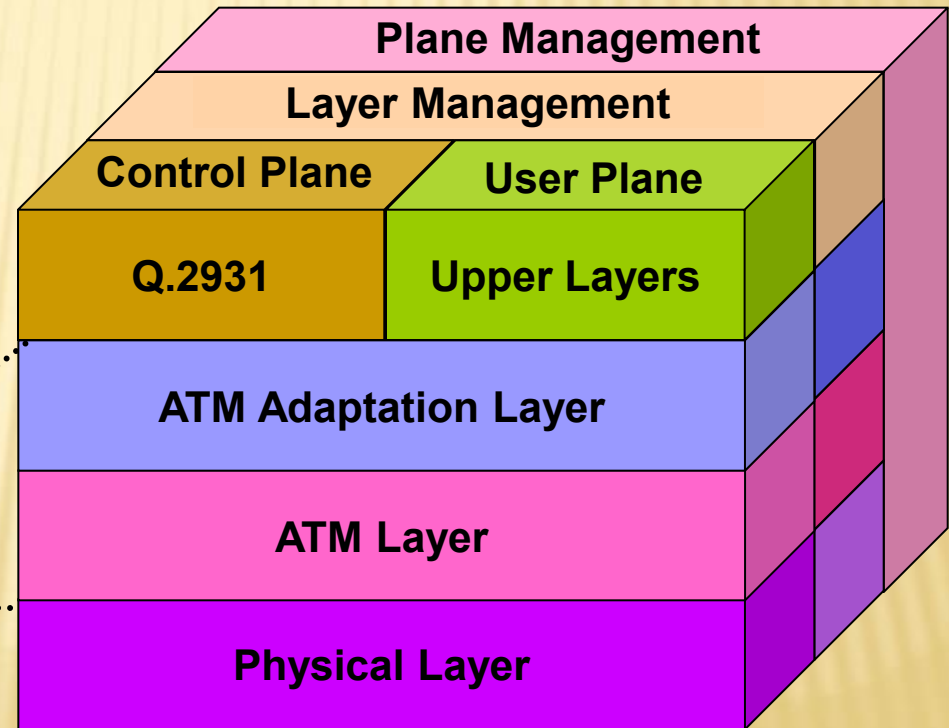

ATM REFERENCE MODEL

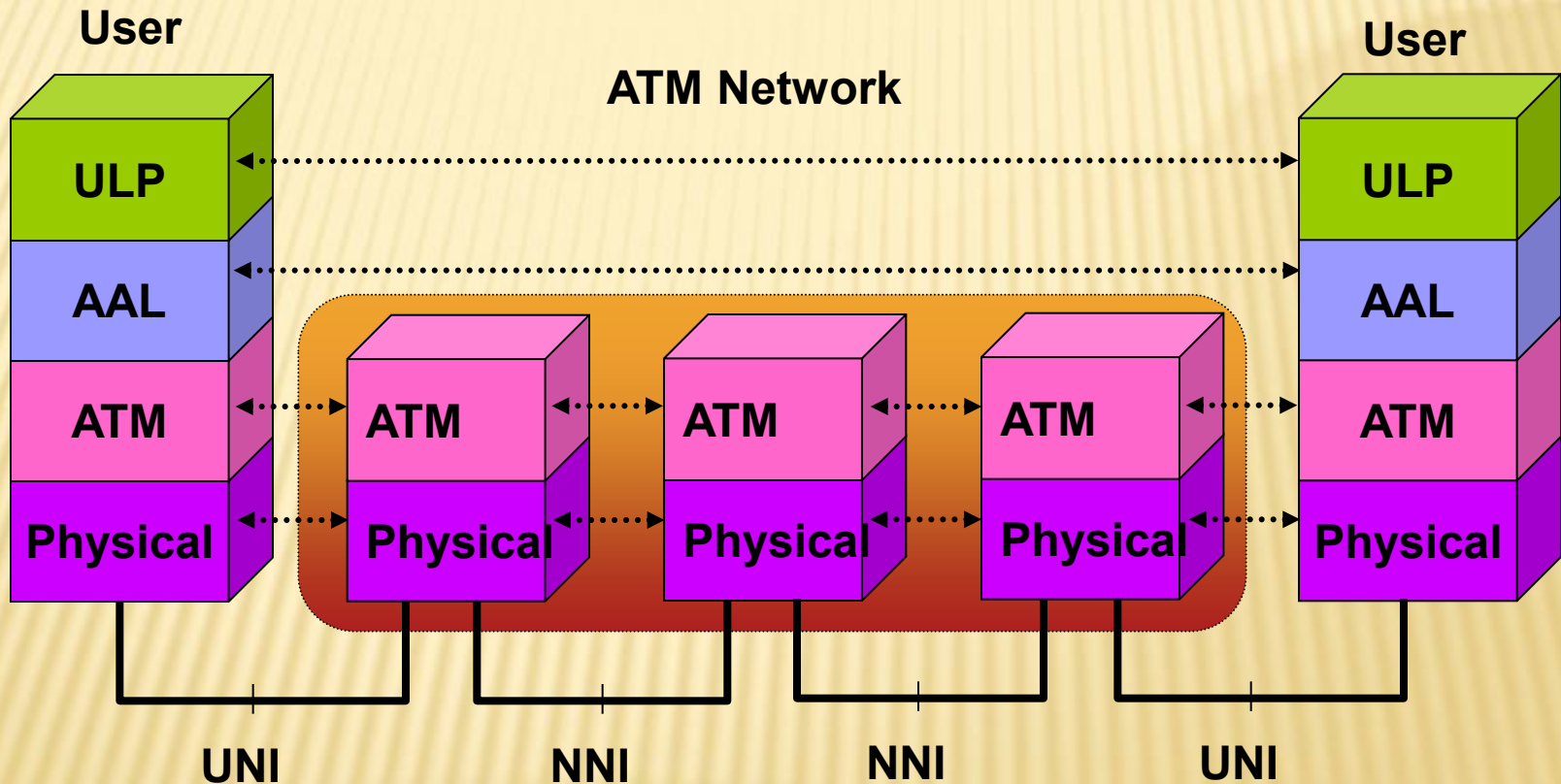

Transfer of User Payload

ATM REFERENCE MODEL

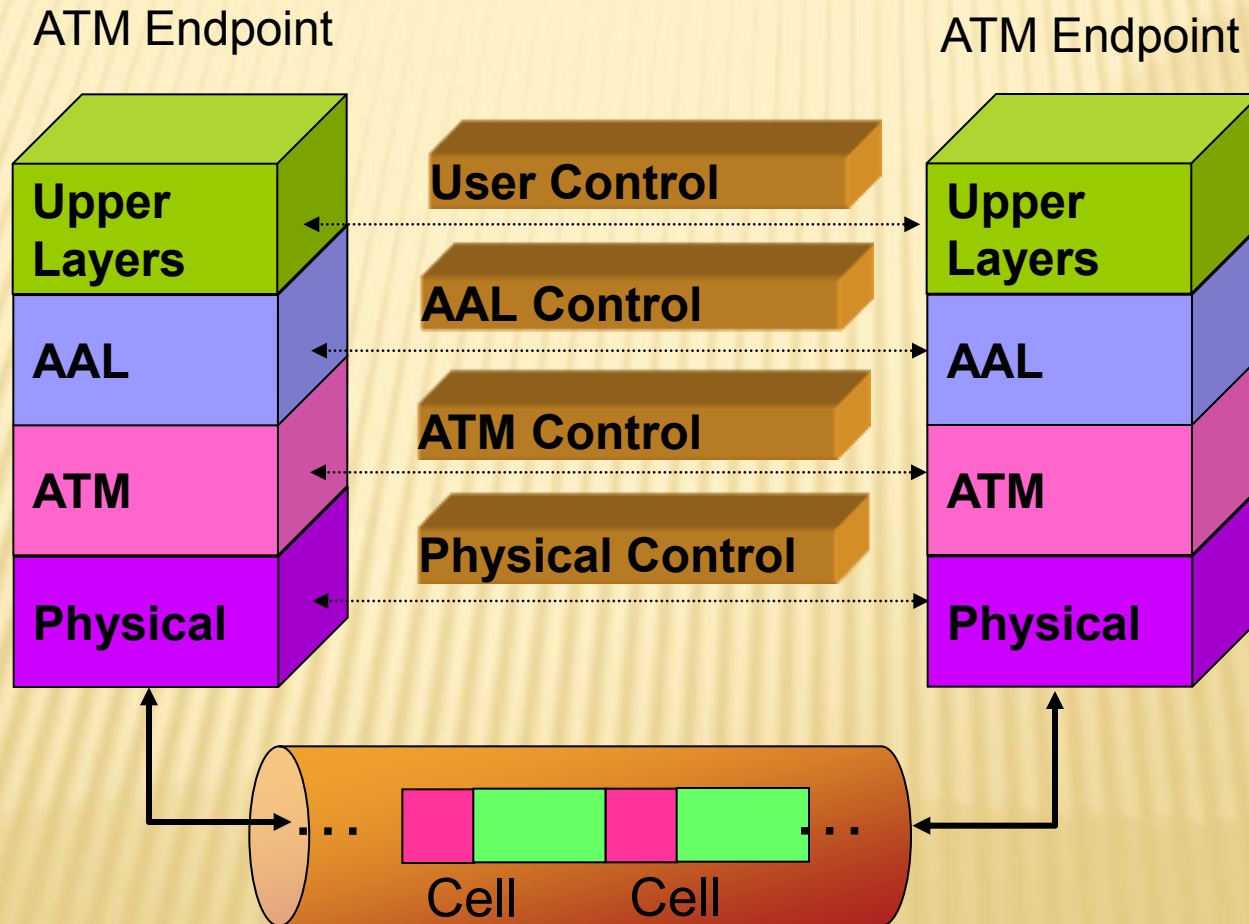

ATM REFERENCE MODEL

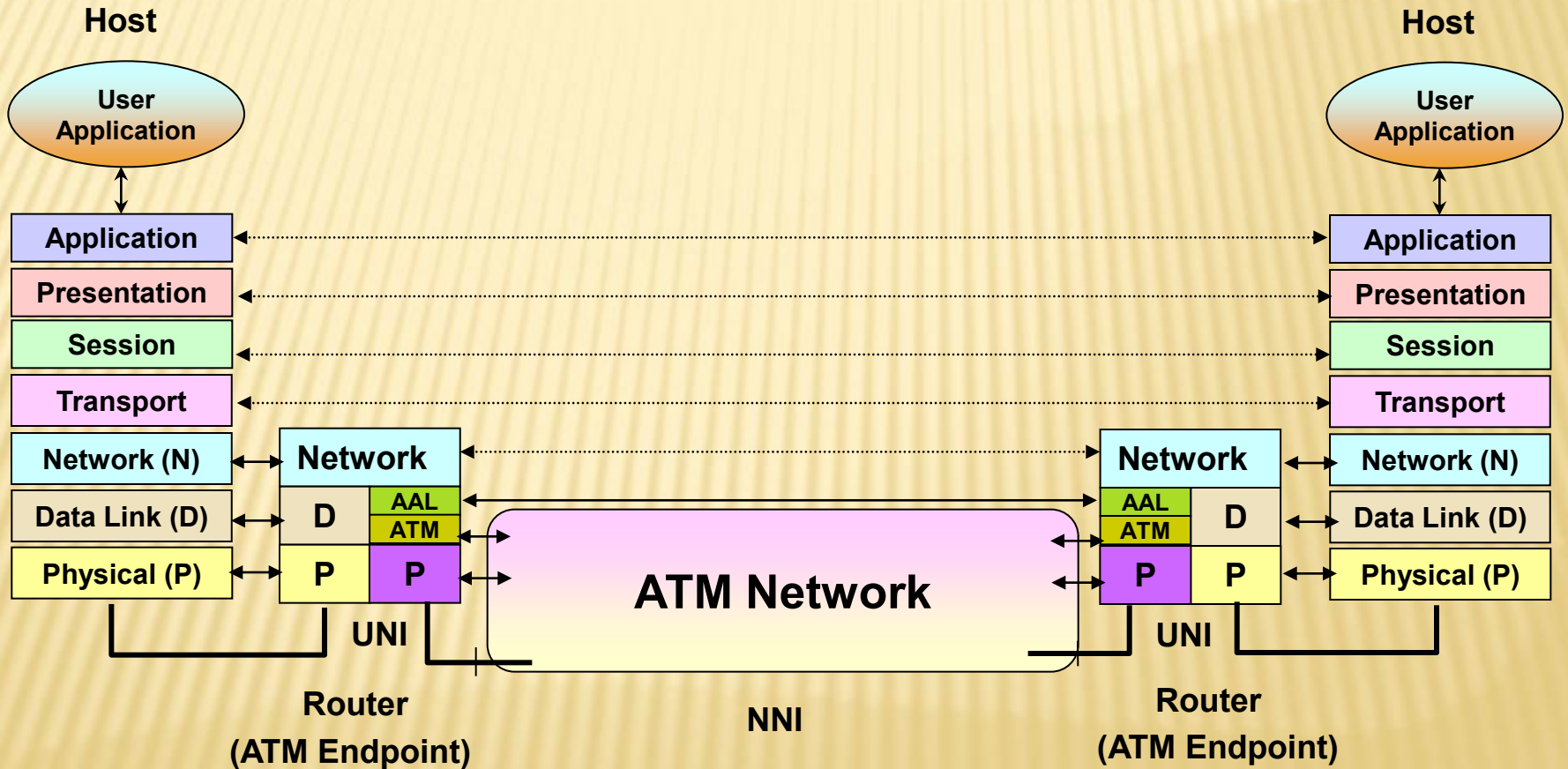

ATM REFERENCE MODEL

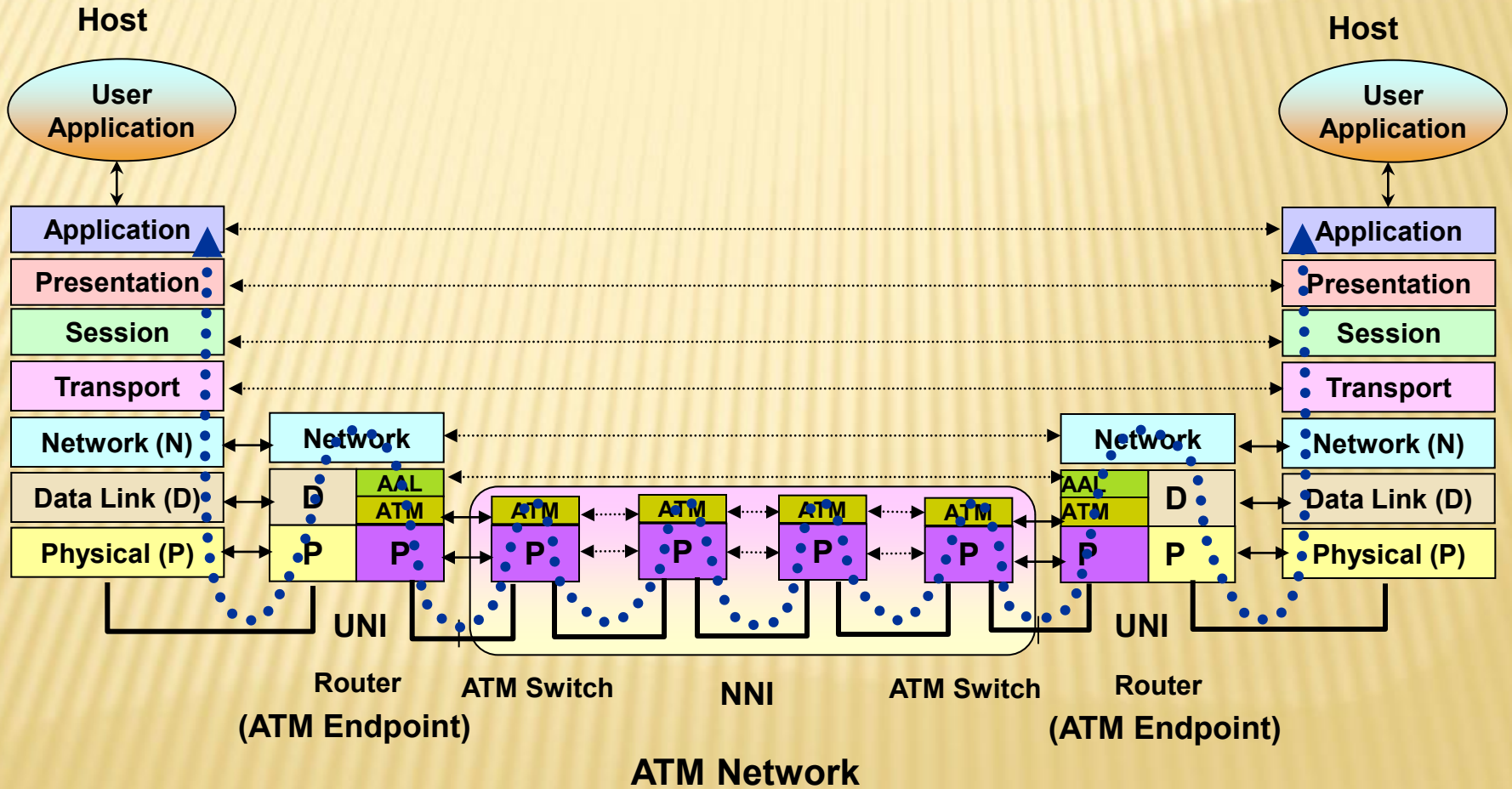

ATM REFERENCE MODEL

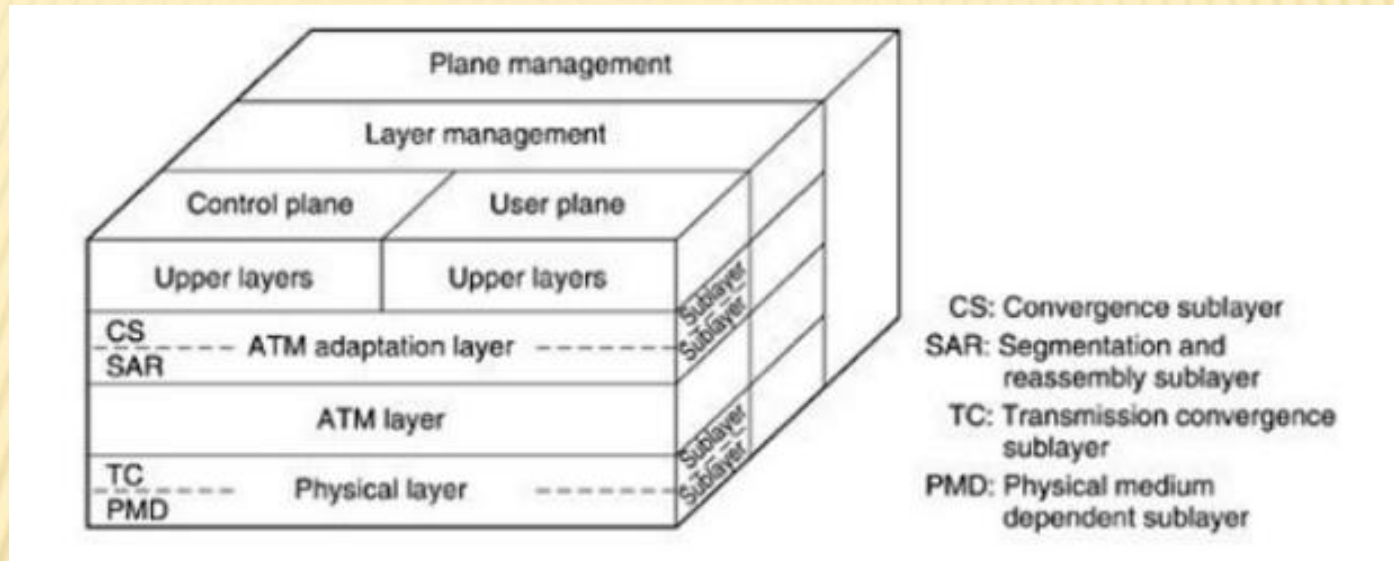

The *physical* and *AAL* layers are divided into two sublayers, one at the *bottom* that does the work and a *convergence sublayer* on the *top* that provides the proper interface to the layer above it.

ATM REFERENCE MODEL

AAL	CS	Providing the standard interface
	SAR	Segmentation and reassembly
ATM	ATM	Flow control Cell header generation/extraction Virtual circuit/path management Cell multiplexing and demultiplexing
Physical	TC	Cell delineation Header checksum generation and verification Cell rate decoupling Packing/unpacking cells from the enclosing envelope
	PMD	Bit timing Physical medium

THE ATM PHYSICAL LAYER

- The **ATM physical layer** is divided into **two** parts:

A. The physical medium-dependent (PMD) sublayer.

B. The transmission convergence (TC) sublayer.

- A. The PMD sublayer** provides **two** key functions:

- It synchronizes transmission and reception by sending and receiving a continuous flow of bits with associated timing information.
- It provides the *physical medium specifications* used, including *connector types* and *cable*. Examples of physical medium standards for ATM include *Synchronous Digital Hierarchy/Synchronous Optical Network (SDH/SONET)*, *DS-3/E3*, 155Mbps over Multi-Mode Fiber (MMF), and over Shielded Twisted-Pair (STP) cabling.

- B. The TC sublayer** has four functions:

- **Cell delineation:** It maintains ATM cell boundaries, allowing devices to locate cells within a stream of bits.
- **Header error control (HEC) sequence generation and verification:** It generates and checks the header error control code.
- **Cell-rate decoupling:** To maintain synchronization, it inserts idle ATM cells at the sending end and extract them at the receiving end to *adapt* the rate of valid ATM cells to the *payload capacity* of the transmission system.
- **Transmission frame adaptation:** To package ATM cells into frames acceptable to the particular physical layer implementation.

HEADER CHECKSUMMING

- Each cell contains a 5-byte header consisting on 4 bytes followed by a 1-byte checksum (HEC).
- The contents of the header are *meaningless* to the TC sublayer.
- The checksum only covers the *first four header bytes*, not the payload field.
- It is up to the *higher layers* to checksum the payload field.
- The HEC scheme *corrects all single-bit errors* and *detects many multi-bit errors* as well.

CELL TRANSMISSION

- Once the HEC has been generated and inserted into the cell by the *TC sublayer*, the cell is ready for transmission.
- Transmission media comes in two categories: *asynchronous* and *synchronous*.
- When an *asynchronous medium* is used, a cell can be sent whenever it is ready to go. No timing restrictions exist.
- With a *synchronous medium*, cells must be transmitted according to a predefined timing pattern.
- If no data cell is available when needed, the *TC sublayer* adds *idle cells*.
- Another kind of non-data cell is *Operation and Maintenance (OAM)* cell which used by the ATM switches for exchanging control information for keeping the system running.
- The job of matching the ATM output rate to the rate of the underlying transmission system is a task of the *TC sublayer*.
- Finally, the TC sublayer generates the **SONET/SDH** framing and pack the ATM cells inside.

CELL RECEPTION

- ❑ On the receiver side, the TC sublayer:
 - ❑ Takes an incoming bit stream, locates the cell boundaries.
 - ❑ Verifies the headers (discarding cells with invalid headers).
 - ❑ Processes OAM cells.
 - ❑ Passes the data cells up to the ATM layer.
- ❑ With **SDH/SONET**, cells can be aligned with the *synchronous payload envelope (SPE)*, so the SPE pointer in the **SONET/SDH** header points to the start of the first full cell.

THE ATM LAYER

- ❑ It defines the *layout of a cell* and tells what the header fields mean.
- ❑ It also deals with Virtual circuit/path management.
- ❑ *Flow control* is also handled by this layer.
- ❑ The ATM layer is responsible for the simultaneous sharing of virtual circuits over a physical link (*cell multiplexing*) and passing cells through the ATM network (*cell relay*) by using the **VCI/VPI** information in the header of each ATM cell.

THE ATM ADAPTATION LAYER (AAL)

- **ATM adaptation layer (AAL)** Combined with the ATM layer, the AAL is roughly *similar to the data link layer* of the OSI model. The AAL is responsible for *isolating* higher-layer protocols from the details of the ATM processes. The adaptation layer prepares user data for *conversion into cells* and segments the data into 48-byte cell payloads, and reassembles them at the other end
- Finally, the *higher layers* residing above the AAL accept user data, arrange it into packets, and hand it to the AAL.

- × **The AAL layer is split into :**
 - + *A segmentation and Reassembly sublayer (SAR)*: It breaks packets up into cells on the transmission side and put them back together again at the destination.
 - + *A Convergence Sublayer (CS)*: It makes it possible to have ATM systems offer different kinds of services to different applications (e.g., *file transfer* and *video on demand* have different requirements concerning error handling timing, etc.).

PRINCIPLE TASKS OF THE AAL

- ❑ The AAL is designed to support different types of applications and different types of traffic, such as voice, video, and data.
- ❑ Once the analog signals have been converted to digital, all transmissions can be treated as data bits.
- ❑ However, if we examine the transmission requirements of voice and data, they are quite different.
 - ❑ Voice and lower-quality video transmissions exhibit a *high tolerance for errors*. In contrast, data transmissions have *no tolerance* for errors.
 - ❑ Packets may be *discarded* in the event of congestion in the network.
 - ❑ The *network delay* for the voice and video cells must be constant and must be low. In contrast, specific data applications exhibit different delay requirements. For example, LAN-to-LAN traffic is more delay sensitive than E-mail traffic.
 - ❑ Voice and video transmissions require a short *queue length* at the network nodes in order to reduce delay. However, data packets require the queue length to be longer to prevent packet loss.

CONGESTION CONTROL

- ❑ Several strategies are used in ATM networks for Congestion Control:
 - ❑ *Admission Control.*
 - ❑ *Resource Reservation.*
 - ❑ *Rate-Based Congestion Control.*

ADMISSION CONTROL

- ❑ The major tool for preventing congestion is *admission control*.
- ❑ When a host wants a *new virtual circuit*, it must describe the *traffic to be offered* and the *service expected*.
- ❑ The network can then check if it is possible to handle this connection without affecting the existing connections.
- ❑ Multiple potential routes may have to be examined to find one which can do the job. If *no route* can be located, the call is *rejected*.
- ❑ A small number of high-bandwidth users can severely affect many low-bandwidth users. To prevent this users should be divided into classes based on usage.

RESOURCE RESERVATION

- ❑ The second technique is to *reserve resources* during call setup time.
- ❑ The network has the possibility of reserving enough bandwidth along the path to handle that rate.
- ❑ If the **SETUP** message hits a line that is full, it must *backtrack* and look for an *alternative path*.
- ❑ With **CBR** and **VBR** traffic, it is generally not possible for the sender to slow down, even in the event of congestion.
- ❑ With **UBR**, the cells are just dropped.
- ❑ With **ABR** traffic, it is possible for the network to signal one or more senders and ask them to slow down temporarily until the network can recover. It is an interest of the sender to comply, because the network can punish the sender by throwing out the excess cells.

- ❑ There are two solutions: *Credit-Based Solution & Rate-Based Solution*
 - ❑ The *credit-based solution* requires each switch to maintain, per virtual circuit, a *credit* — a number of buffers reserved for that circuit. As long as each transmitted cell has a buffer waiting for it, congestion could never arise. The switch vendors are against of this solution because of the large overhead.
 - ❑ The *rate-based solution* congestion control scheme was adopted. It works like this:
 - ❑ After every k data cells, each sender transmits a special **Resource Management (RM) cell**. This cell travels along the same path as the data cells, but it is treated specially by the switches along the way. When it gets to the destination, it is examined, updated, and sent back to the sender.
 - ❑ In addition, overloaded switches generate **RM** cells and ship them back to the sender.