

Chapter 5

Electric Logic Sensors and Actuators

- 5.1 Introduction.
- 5.2 Nearby or proximity logic detectors.
 - 5.3.1 Contact switches
 - 5.3.2 Reed switch
 - 5.3.3 Mercury switch
 - 5.3.4 Photoelectric switches
 - 5.3.5 Inductive proximity sensors
 - 5.3.6 Capacitive proximity sensors
- 5.3 Applications of proximity sensors
- 5.4 Logic actuators
 - 5.4.1 Displacement solenoids.
 - 5.4.2 Relay switching element.
- 5.5 Sensor wiring

5.1 Introduction to Electric Logic Sensors and Actuators

Electric sensors and **actuators** can be classified to be as **continuous and logic**. **Logic sensors** are used with PLC to detect the state of the process as true or false (on or off) in logic control. Similarly **logic actuators** are used with PLC to activate or deactivate the logic switching elements, that will drive the mechanical system.

Examples of using logic sensors:

- Mechanical limit switch used to detect the object approaching.
- Optical sensor or detector used to detect an object is breaking the beam of light.
- Capacitive detector used to detect the existing of dielectric object.
- Inductive detector switch used to detect the existence of a ferrous metal object.
- A thermostat switch (such as those used in refrigeration and air conditioning) opens or closes a contact when a certain temperature is reached.

5.1 Introduction to Electric Logic Sensors and Actuators

On the other hand, continuous sensors are those, which generate a continuous signal (voltage or current) that proportional with the actual physical variable. This signal has either analog or digital values depend of the type of the sensor and can be fed very easily to the *PLC* module to measure the physical variable. For example, a linear potentiometer will generate analog output signal proportional to linear displacements.

The continuous actuators are also used with *PLC* to activate or deactivate the digital or with analog amplifier that will drive the mechanical system proportional to the value of the control signal. For example, the analog output signal from PLC can be used to activate a linear amplifier that will control the speed of a DC motor.



Linear Analog DC servodrives



Linear potentiometer

5.2 Nearby or Proximity Logic Detectors

There are two ways to detect the existence of an object, either by direct mechanical contact using a physical force contact or using proximity technique (no physical contact)

Contact switches

Internally, contact switches consist of electric contacts driven by mechanical lever and spring. When applying a small force on this mechanical lever it will actuate the contact. Removing the force will return contact to its original position.

Contact switches are available with either normally closed NC or normally opened NO contacts. Micro limit switches can be found with small equipment, while heavy-duty limit switches (more expensive) can be found with large equipment.

Contact switches can be used as motion limit switches or as push buttons switches and used as user-machine interface switches, e.g. start/stop push button switches.

5.2 Nearby or Proximity Logic Detectors

Contact switches

Internally, contact switches consist of electric contacts driven by mechanical lever and spring. When applying a small force on this mechanical lever it will actuate the contact. Removing the force will return contact to its original position.

Contact switches are available with either normally closed NC or normally opened NO contacts. Micro limit switches can be found with small equipment, while heavy-duty limit switches (more expensive) can be found with large equipment.

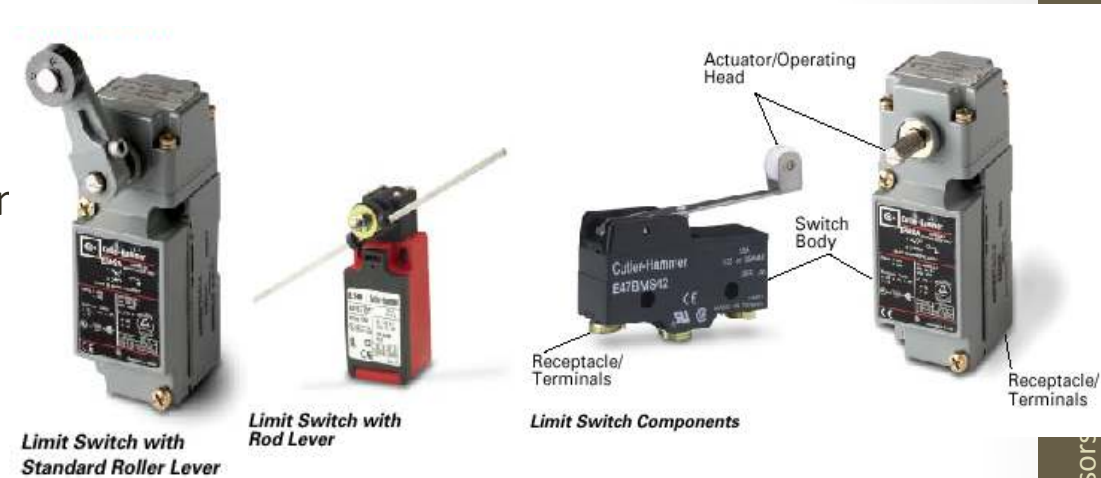

Fig 5.1 Examples of contact switches used as industrial limits switches.



Fig 5.2 Examples of contact switches used as push-button, key type and selector switches used as machine-user interface bottoms.

5.2 Nearby or Proximity Logic Detectors

Contact switches

In many automation applications, the limit switches represent the weakest link of the control system. It has been estimated that 90% of machine automation failures are from limits switches. This is because in fact that these sensors are located almost in the places where action is. These switches are usually located in hot area, moisture, corrosive atmosphere ...etc.

According to the contact configuration, contact switches are of two types, single-pole single-throw (SPST) contact. The majority of limit switches contain both an NO and NC contact, but with a common pole producing what is called single-pole double-throw (SPDT) configuration. This type of switches is called “change over” or “transfer” contacts, see Fig. 5.4.

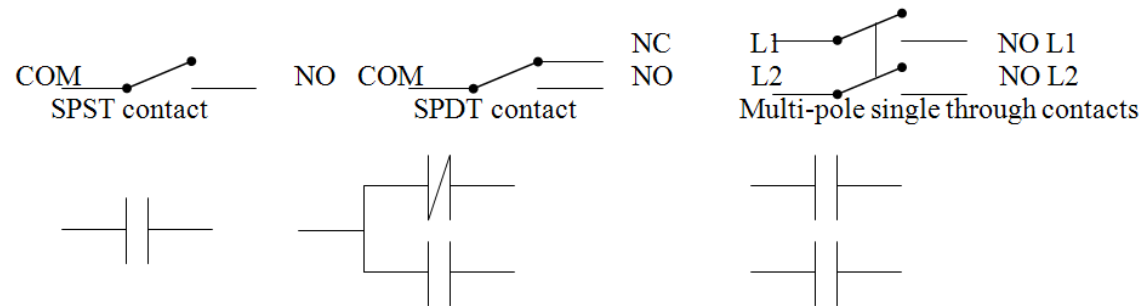

Fig. 5.4 Different contact symbols for contact switches.

5.2 Nearby or Proximity Logic Detectors

Contact switches

In any electric circuit diagrams, it is customary to draw each switch contact (no matter whether it is NO or NC) the way it appears at the beginning of a machine cycle, with system at rest.

For example, cylinders frequently have two limit switches mounted along the piston-rod path, in order to indicate piston position. One switch, say *switch a-*, is usually mounted to be actuated when the cylinder is retracted, whereas the second, *switch a+*, is actuated when the cylinder piston is completely extracted. Assume that the cylinder is retracted at the beginning of a cycle.

We would therefore draw all contacts of *switch a-* (no matter whether it is NO or NC) in their actuated position, whereas contacts of *switch a+* would be drawn in their normal position.

5.2 Nearby or Proximity Logic Detectors

Contact switches

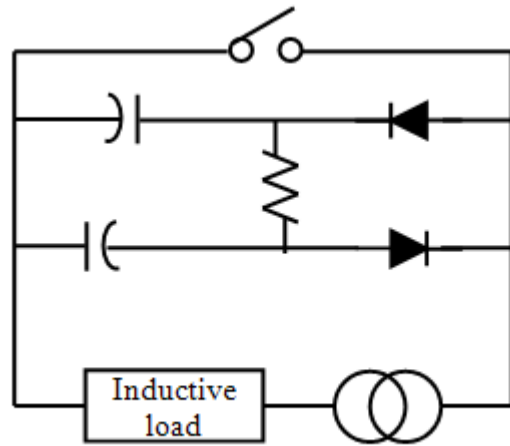

Resistor-capacitor-diode (for ac load): the circuit can be connected to load or contact. For example 115V, PIV for diode 400Vac, working voltage for capacitor 200Vac, resistor 100 Ω 1W.

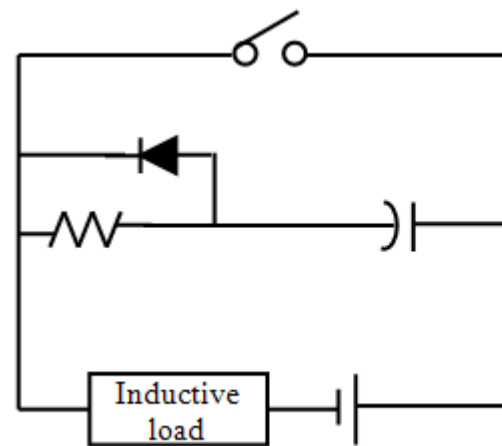

Resistor-capacitor-diode (for dc load): The capacitor charges through the diode but can discharge only through the resistor. Thus, the voltage drop across the contacts is zero as they open. The capacitor value is chosen so that the peak voltage to which it charges does not cause a breakdown of the diode, the contact gap.

Fig. 5.5 The Arc-suppression circuits used for inductive AC and DC load.

5.2 Nearby or Proximity Logic Detectors

Reed switches

A reed switch consists of two leaf springs (the reeds) sealed in a small glass tube, with two free ends overlapping and almost touching. Reed switches are nearly similar to electro-mechanical relays, except that the magnetic field is developed by permanent magnet instead of electric coil. The permanent magnet is mounted on the moving part. Fig. 5.6 shows how reed switch operates. As long as the permanent magnet moved toward the reed

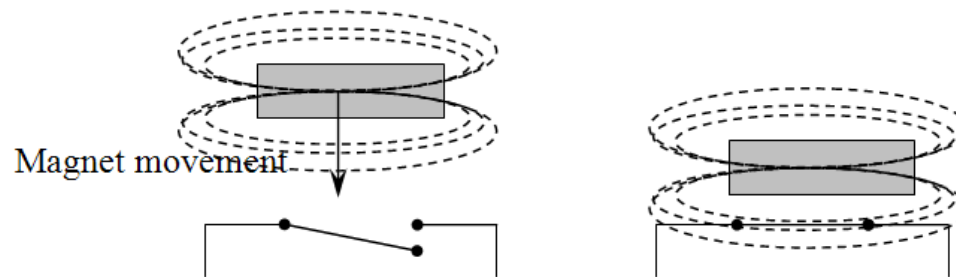

Fig 5.6 Reed switch operation.

switch and get closer the switch will close or open the contacts, depending on the contact type NO or NC contact. Thus, unlike limit switches, reed switches are actuated without physical contact and the actuating element.

Reed switches are filled with inert gas during sealing, their contact are resistance to corrosion and contamination. The life of reed switch is more than 100 million operation.

An example for this application, is a magnet attached to piston rod or pneumatic cylinder, the two extreme positions of the cylinder are reported, using two reed switches on the extreme positions

5.2 Nearby or Proximity Logic Detectors

Mercury switches

Mercury switches are small hermetically sealed glass tubes containing two contact terminals and sufficient mercury to bridge them. The switch is opened or closed by tilting the tube, causing the mercury to run into or out of the terminal region. Mercury switches have several advantages:

- The actuation force is low, since tilting actuates the switch.
- Since the terminals are wetted by a fairly large amount of mercury, contact resistance is very small.
- Current interruption does not harm the mercury. Thus, there is no contact to burn out. The only limitation is overheating produced by arcing. With light load, mercury switches provide extremely long life.

However, there are several drawbacks:

- Mounting is critical, since unwanted tilt can cause false actuation.
- Vibration can cause false actuation.
- They are not suitable for high cycling rates because of mercury inertia.

5.2 Nearby or Proximity Logic Detectors

Photoelectric switches

Photoelectric sensors consist basically of a source emitting a light beam and a light-sensing detector receiving the beam. The object to be sensed interrupts or reflects the beam, thereby making its presence known without physical contact between sensors and object.

5.2 Nearby or Proximity Logic Detectors

Photoelectric switches

Photoelectric sensors operate according to one of the following three modes of operation, see Fig. 5.7.

1. In the operation mode of the through-beam photoelectric sensor, the emitter and detector are mounted in separate housings which is aligned carefully so as to face each other exactly. As the target to be detected approaches, it breaks the beam. In this type of operation the sensor can work for larger length up to 100 m, provided the beam is concentrated and the air is clean also the emitter and detector are accurately aligned. An interesting variation of the through-beam principle can be used as smoke detector (such as in domestic fire alarm).

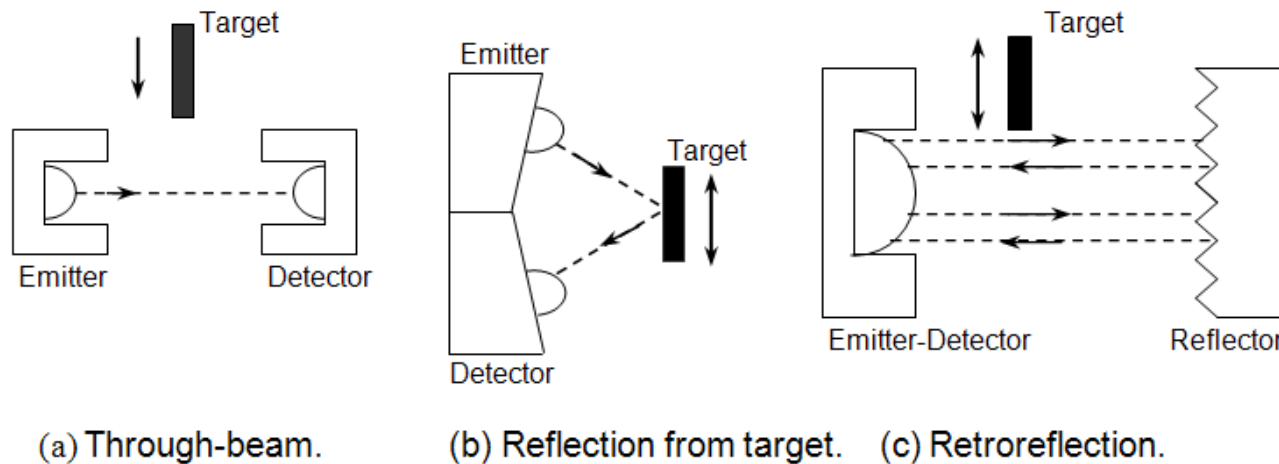

5.2 Nearby or Proximity Logic Detectors

Photoelectric switches

Photoelectric sensors operate according to one of the following three modes of operation, see Fig. 5.7.

2. In the reflection operation mode of photoelectric sensor, the emitter and detector are built into a single housing, which reduces wiring and mounting cost. The target, when it reaches the proper location, reflects the beam back into the detector. Since only part of the emitter light returns to the detector, this mode is only suitable for fairly small distances, where the air must be reasonably clean of contamination. The method can be used for detecting the liquid level.

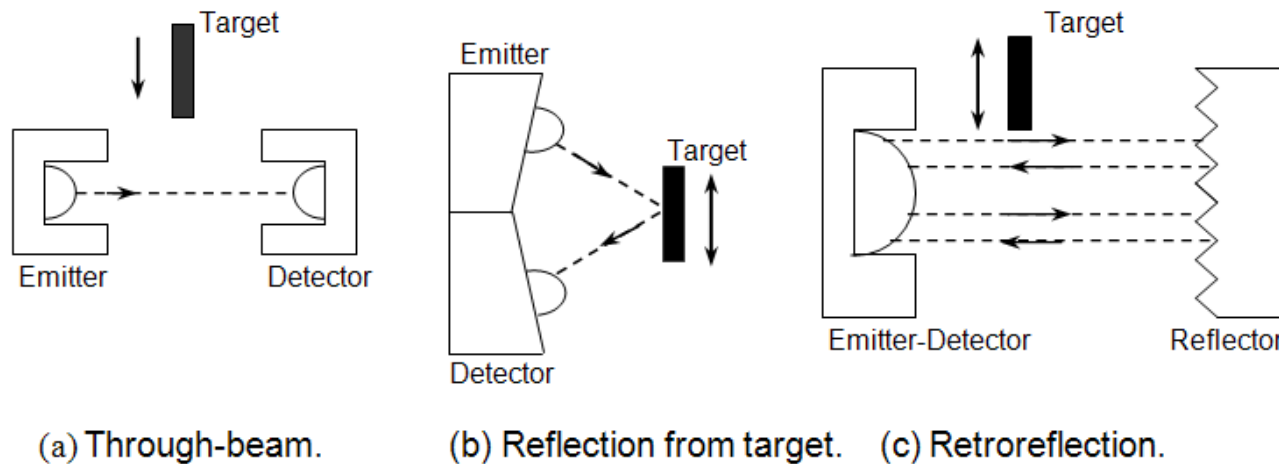

5.2 Nearby or Proximity Logic Detectors

Photoelectric switches

Photoelectric sensors operate according to one of the following three modes of operation.

3. In the retroreflection operation mode, a special reflector (typically a formed plastic surface with small embedded spheres or pyramids) reflects the light beam back into the detector, regardless of the angle of incidence, unless the target interrupts it. Here also the emitter and detector are mounted on the same housing. This method can be used to sense a distance up to 10 m in the absence of atmospheric contaminations.

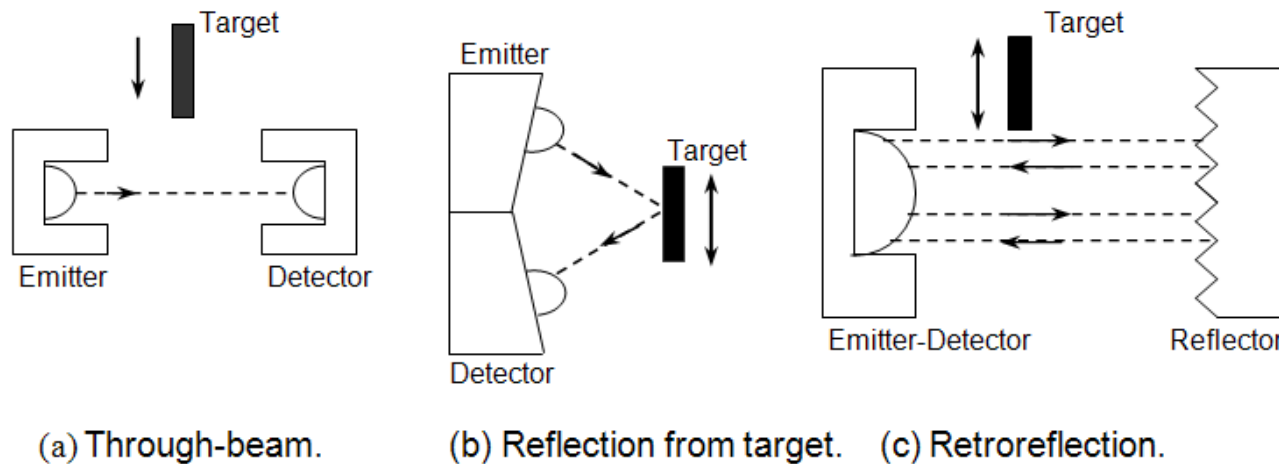

5.2 Nearby or Proximity Logic Detectors

Inductive proximity switches

- Strictly speaking, the reed switches and photoelectric sensors discussed so far, are all proximity sensors. However, the term “proximity sensors” generally refers to devices based on inductive, capacitive or magnetic effects, with some electronic circuits, that can detect the presence of an object.
- These proximity sensors are usually packed in one of two ways. Some come in standard limit-switch enclosures, which facilitate interchangeability and maintenance and other called threaded-barrel type.
- Most inductive proximity sensors operate by generating high-frequency electromagnetic fields that induces eddy current in the metal target.
- The sensor inductance is part of an oscillator circuit. When the target (which must be a conducting material) near the sensor the oscillations are damped. This resulting in change in oscillator current which actuates a solid-state switch. Sensing distance from 2 to 30 mm, also depends on the target size, thickness, material, and temperature. The material of the object must be ferrous material



5.2 Nearby or Proximity Logic Detectors

Capacitive proximity switches



These contain a damped RC oscillator. When a target, which need not be of conducting materials (such as liquid, water, oil, powder, wood, plastic ...etc), is brought within operating range of the sensor, the resulting change in capacitance causes the circuit to actuate a solid-state switch. The maximum sensing distances range from 5 to 40 mm, depend on the sensor design and target material.

The main advantage of the capacitive proximity sensors is that they are not limited to metallic targets. Thus, they can be used to detect the level of a liquid or solid material in the vessel. Also they can detect objects inside sealed containers. However, their switching accuracy is affected by humidity and temperature. They have low responses for detecting very high speed moving objects when compared to the inductive sensors.

Other proximity sensors are magnetic proximity sensors, such as magnetic inductance sensors, hall-effect sensors ...etc.

5.3 Applications Nearby or Proximity Logic Detectors

A capacitive proximity sensor used to verify fill level of bottled water on a filling process line.

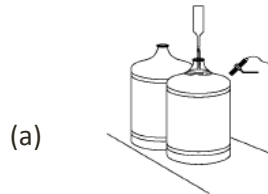

(a)

A clear object sensor is used to sense the presence of bottles at a filling operation. The sensor offers high reliability in sensing clear bottles of different colors and thicknesses.

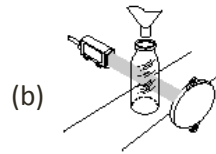

(b)

A reflex control with a time delay module set for "delay dark" ignores momentary beam breaks. If the beam is blocked longer than the delay period, the output energizes to sound an alarm or stop the conveyer.

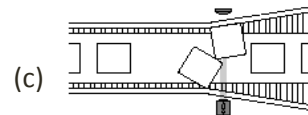

(c)

A tubular inductive proximity sensor used to detect the presence of metal carriers holding parts to be machined.

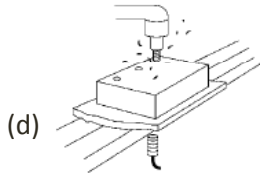

(d)

A pair of tubular proximity sensors used to, a) detect the presence of a can on a conveying line, and b) check for presence of lid.

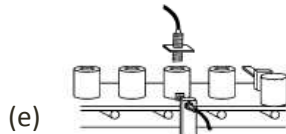

(e)

A pair of E53 capacitive proximity sensors used to sense high and low liquid levels in a tank through a sight glass. This arrangement would fill the tank when the lower sensor is energized and shut the pump off when the top sensor is energized.

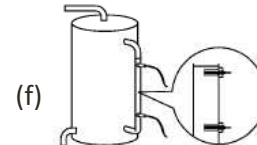

(f)

A capacitive proximity used to control fill level of solids such as plastic pellets in a hopper or bin.

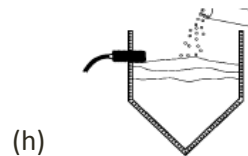

(h)

A pair of tubular proximity sensors used to determine full open and fully closed valve position.

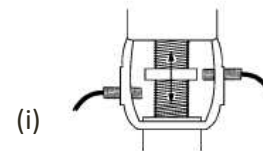

(i)

a) Capacitive type.

b) Retro-reflection optical.

c) Retro-reflection optical.

d) Inductive type.

e) Inductive or capacitive

f) Capacitive.

g) Retro-reflection or thru-beam.

h) Capacitive.

i) Inductive.

j) Capacitive or thru-beam.

k) Thru-beam

l) Thru-beam optical type.

m) Thru-beam type.

n) Inductive (steel cans) or reflection from target optical type.



Proximity Sensor Types

5.3 Applications Nearby or Proximity Logic Detectors

A safe and secure garage is achieved through the use of thru-beam controls interfaced to the door controller. The door shuts automatically after a car leaves, and if the beam is broken while the door is lowering, the motor reverses direction and raises the door again.

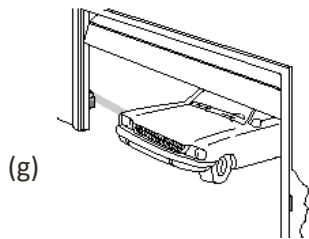

An array of thru-beam controls detect the length of the log in standard two-foot increments. The correct saw is then activated to cut the log at its longest standard length. High optical performance is a must in this dusty and dirty environment.

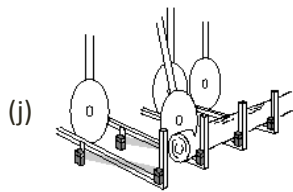

- g) Retro-reflection or thru-beam.
- h) Capacitive.
- i) Inductive.
- j) Capacitive or thru-beam.
- k) Thru-beam
- l) Thru-beam optical type.
- m) Thru-beam type.
- n) Inductive (steel cans) or reflection from target optical type.

(h)

Remote sensors inspect for the presence of holes in a metal casting. Because each hole has its own inspection system, accurate defect information is recorded. Rugged sensor housing and extremely high signal strength handle dirt and grease with minimum maintenance. Using the modular control unit allows for dense packaging in small enclosures.

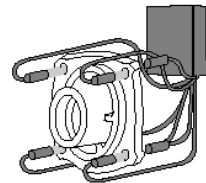

(k)

(i)

A reflex control with a motion detection module counts the revolutions of the wheel. Speed is controlled by a programmable controller. Provides timing ranges from 2.4 to 12,000 counts per minute.

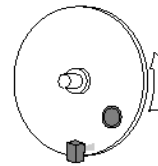

(l)

A pair of tubular proximity sensors used to, a) detect the presence of a can on a conveying line, and b) check for presence of lid.

(m & n)

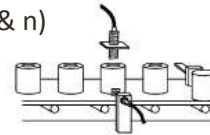

Proximity Sensor Types

5.4 Logic actuators

5.4.1 Displacement solenoids

Solenoids are electromechanical devices consisting of an electromagnetic coil and plunger (also called armature), as illustrated in figure 5.10. When current is sent through the coil, the resulting magnetic field draws the sleeve within the coil; this will convert the electric energy to mechanical linear displacement (linear or rotary displacements).



Fig. 5.10 Different types of linear and angular displacement solenoids. [Ledex and Dormeyer Product www.ledex.com]

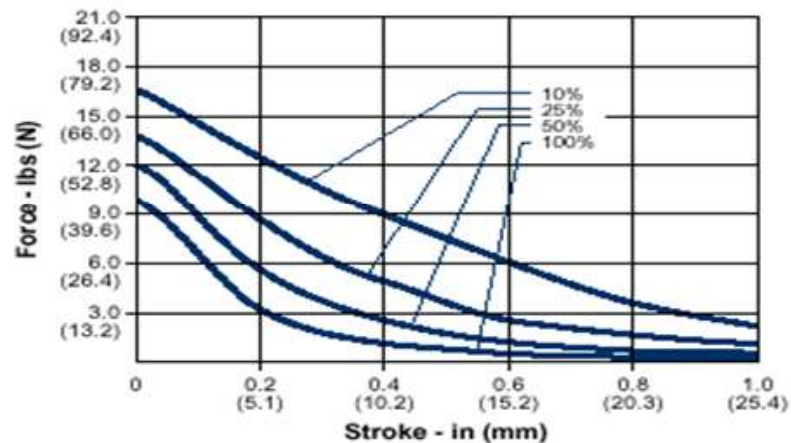
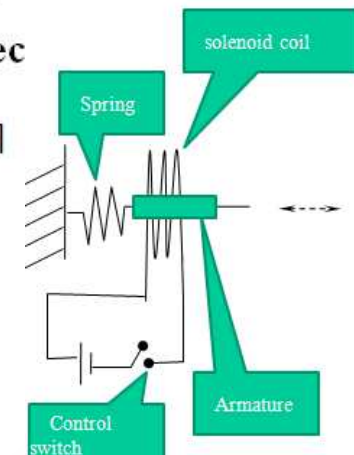

Fig. 5.11 Performance curve for a selected solenoid. [Ledex and Dormeyer Product www.ledex.com]



5.4 Logic actuators

Displacement Solenoids

These solenoids are used frequently with many industrial assembly machines to provide either linear or angular displacements. Solenoids can be of two types, linear displacement and angular displacement solenoids. For example, rotary solenoid has angular displacement from 5 to 200 deg., at different torque values.

Different factors must be considered when assigning a solenoid for an industrial application; which can be summarized as follows:

- Solenoid life; it is important to consider the effects of heat, since an increase in coil temperature reduces the work output and the life of the unit. Standard life is 50000 to 100000 operations.
- Duty cycle f ; duty cycle is determined by solenoid ON time / (On+OFF time). For example; a solenoid is actuated for 30 seconds, then off for 90 seconds, the duty cycle equal to 30 sec. ON divide by (30 sec. + 90 sec OFF) equal to 0.25 (i.e. duty cycle equal to 25%). For example, the allowable load for $f=0.1$ is about 5 to 10 times as high as at $f=1$ (i.e. continuous operation).
- Other important factors; solenoid actuation type (pull or push type), the required stroke, force or torque required. Finally it is important to select the solenoid from the performance curves (force-displacement curves) provided from manufacture, (see Fig. 5.11).

5.4 Logic actuators

Example 5.1;

Consider a linear solenoid to be operated 20 seconds as ON and will be off for 150 seconds, working stroke 5 mm and pull force 10 Newtons. Determine the duty cycle and select the proper solenoid from the provide performance curves, see Fig. 5.12?

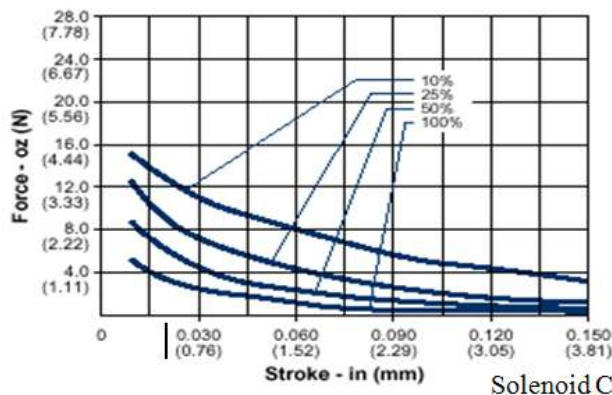
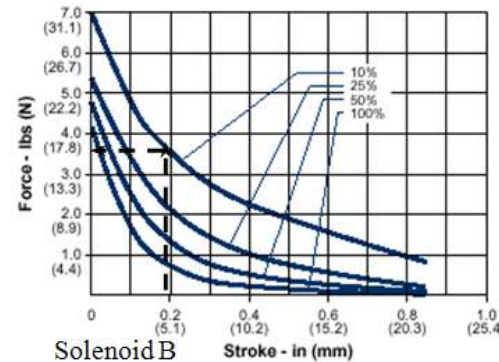
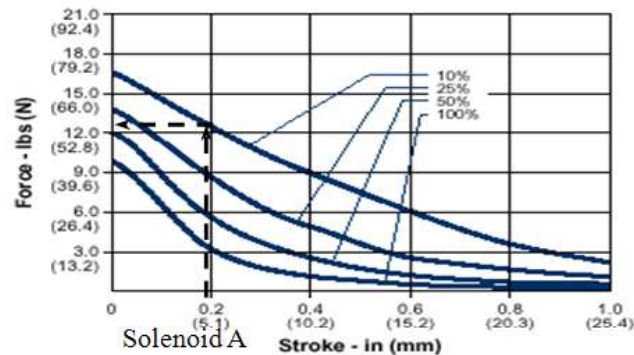

Fig. 5.12 Performance curves for three solenoids *a, b, and c*(see Example 5.1).

Duty cycle equal to $20/(20+150)= 0.117$ or $\sim 11\%$. It is clearly observed that solenoid-C will not provide the required linear displacement (maximum displacement 3.81 mm in current case). Solenoid-B provides the required displacement at duty cycle 11%, however it will not provide the required force. Solenoid-A provides the required force and displacement at the calculated duty cycle.

5.4 Logic actuators

Example 5.1;

Consider a linear solenoid to be operated 20 seconds as ON and will be off for 150 seconds, working stroke 5 mm and pull force 10 Newtons. Determine the duty cycle and select the proper solenoid from the provide performance curves, see Fig. 5.12?

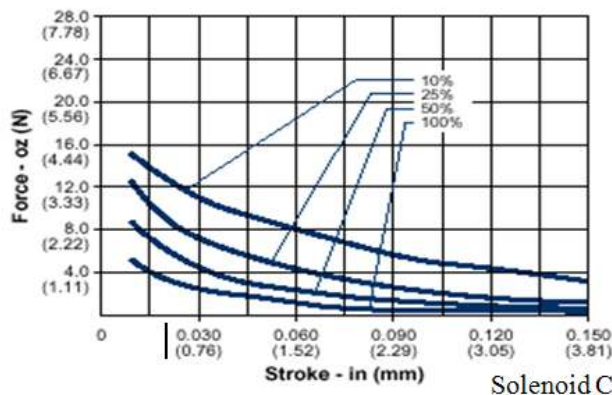
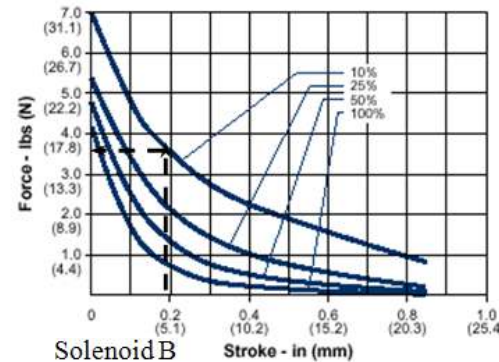
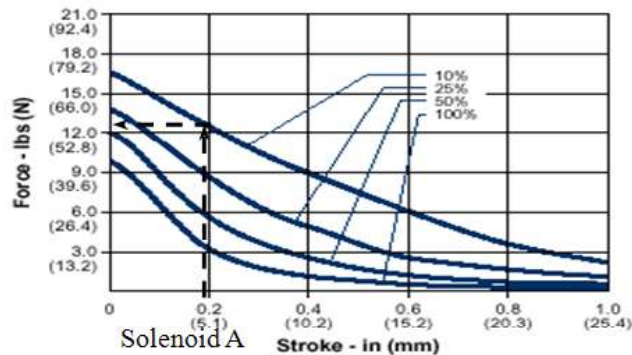

Fig. 5.12 Performance curves for three solenoids *a, b, and c*(see Example 5.1).

Duty cycle equal to $20/(20+150)= 0.117$ or $\sim 11\%$.

It is clearly observed that solenoid-C will not provide the required linear displacement (maximum displacement 3.81 mm in current case).

Solenoid-B provides the required displacement at duty cycle 11%. While solenoid –A, quite big for this application

5.4 Logic actuators

Displacement Solenoids

Solenoid can be actuated using AC or DC current. AC current is noisier compared to DC type. On other hand, DC type require external power supply and much more likely to burn out on excessive loads. Furthermore, AC solenoids develop more force at the beginning than DC solenoid of same size.

In DC solenoids, coil inductance produces high reverse-voltage transients when the solenoid is shut off. Hence, to prevent serious degradation of the switch contacts by arcing, special devices should be used. This phenomenon is more serious at high switching rate (on/off).

The simplest suppression means is a diode connected across the coil winding, which limits reverse voltage to the supply voltage level. However, the solenoid terminals must be polarized to prevent damage to the diode

5.4 Logic actuators

Relay Switch Element

There are three basic relay types: Electromechanical relay, reed relay, and solid-state relays.

Relays are used for two purpose as logic switching elements (i.e. control relay), or as current or voltage amplifiers (i.e. power relays).



Fig. 5.13, a) Structure of electromechanical relay, b) Relay ladder notation, c) NO notation) NC notation and e) changeover contact notation.

5.4 Logic actuators

Relay Switch Element

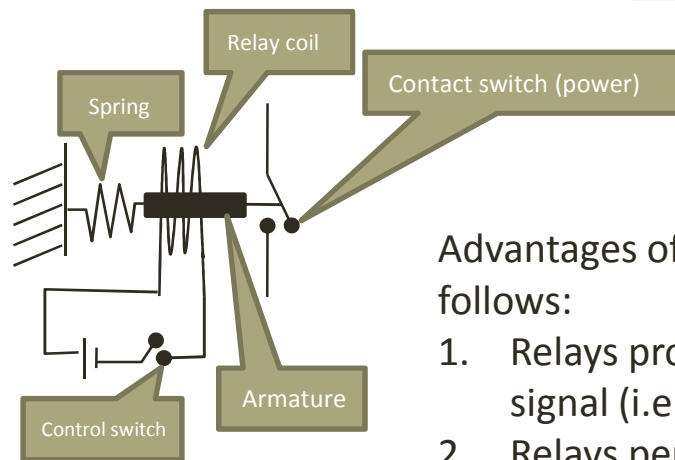

Advantages of using electromechanical relays can be summarized as follows:

1. Relays provide complete electric insulation between the control signal (i.e. coil) and the output load (i.e. contact).
2. Relays permit a small voltage to control a larger one. For instance, an electronic circuit could actuate a 5 Volt relay coil with contact transmitting 115V.
3. Relays act as current amplifier. For instance, a tiny limit switch with limited current-carrying capacity can actuate a relay coil whose, contacts transmit a current driving a large motor.
4. By multi-contact relay, one input signal can control many different loads (possible with different voltages for each load).

5.4 Logic actuators

Reed Relay Switch Element

Reed relays are close to the reed switches. However, while reed switches are actuated by a moving permanent magnet, reed relays contain several reed capsules actuated by one stationary electromagnet. Thus the armature and mechanical linkage is eliminated in EMR and seal reed tubes or capsules replace the contacts, see Fig. 5.14. Life is more than EMR, nearly 10^8 operations, contact rating up to 1 Amp and operating time up to 0.5 msec.

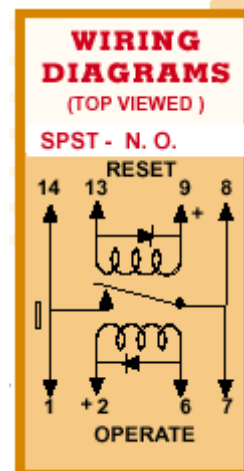
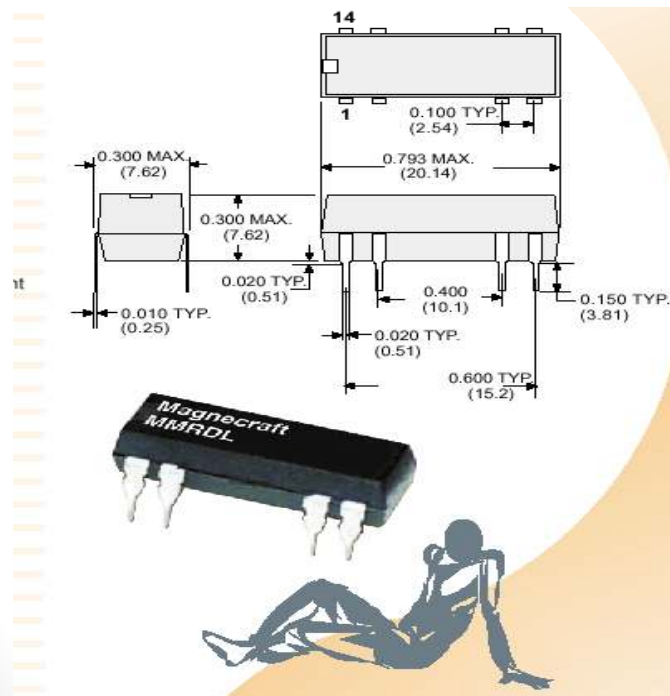

5.4 Logic actuators

Solid State Relay Switch Element

Solid-state relays (SSRs) are invariably compared with EMR and reed relays. Most SSR switches one circuit, equivalent to SPST relay. It is not suitable switching logic operations; used as output elements which interfaces the logic gates to the outside load.

OUTLINE DIMENSIONS
DIMENSIONS SHOWN IN INCHES & (MILLIMETERS).

2.250 (57.2)

1.750 (44.5)

2.665 (67.691)

0.185 MAX. (4.699)

0.475 (12.065)

0.800 (20.32)

1.945 (49.403)

0.996 Max. (25.3) for 40 Amp DDX Models & for 75 to 125 Amps DSX & ASX Models.
0.800 Max (20.32) for Models ASX, DSX & DTX Models up to 50 Amp & DDX 12 Amp Models.

SPST-N.O. 10 TO 125 AMPS

RED L.E.D. STATUS LAMP

UL Recognized File No. E52197

CE On selected models

LIFETIME WARRANTY

SAFETY COVER STANDARD ON ALL MODELS EXCEPT DUAL OUTPUT

INPUT & OUTPUT SCREW SIZE

UP TO 40 AMP	OUTPUT
INPUT	M 4
M 3.5	M 4
ABOVE 40 AMP	
M 3.5	M 6

5.4 Logic actuators

Solid State Relay Switch Element

Advantages	Drawbacks
SSR switch is much faster than EMR and has quite operation.	Their initial cost is greater than EMR
The life of SSR is nearly infinite compared to EMR life.	They can switch only one circuit, hence, multi-SSR required to switch multi-loads
SSR can be switched using low power electronic devices (gates)	They are not as good as positive shutoff devices, since they have a leakage current
Resistance for shocks and vibration, which falsely the EMR	SSR usually fail in the on state, which quite dangerous.
	The application of SSR is not forward like EMR; for example, two types of SSR are used for DC and AC load.
	SSR are not suitable for very high temperature operation.



5.5 Sensor Wiring

When detecting the logic state of a process, the sensor must signal this state to the PLC through switching either voltage or current from on to off or from off to on. The output from the sensor will be an input to the PLC.

Sensor interface to other control circuits (sensor output circuit) are different. The control voltage type, whether AC,DC or AC/DC can be grouped to be as Load-Power Sensor or Line-Power Sensor.

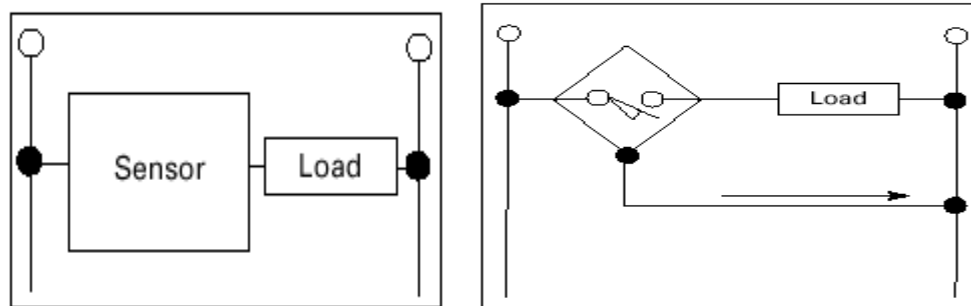

Fig.5.16 types of sensors a) two-wired load-powered sensor, and b)three-wired line-powered sensors.

5.5 Sensor Wiring

Sensor Output Types:

There are mainly three output types: Relay, Triac and Transistor outputs.

1. Relay output: A relay is a mechanical device that can handle load current at higher voltage. This allows the sensor to directly interface with motor, solenoids and other inductive load. They can be used to switch either AC or DC voltage. Relays are subjected to contact wear and resistance build up, which is a function of drawn current, frequency and voltage. Furthermore, due to contact bounce, they can produce erratic results with counters, PLC and other devices, unless the input to these devices is filtered. Furthermore, response time of relay output is too high.

2. A Triac Output: A triac is a solid-state device designed to control AC current. A triac switch turn on in less than microsecond when its gate (control gate) is energized. As long as triac is used within its rated maximum current and voltage, triac has infinite life. Triac devices used with sensors are generally rated at 2A loads or less, and can be used directly interfaced to PLCs. Furthermore, it can be used directly to drive an inductive load using snubber circuit, as shown in Fig. 5.17. The short circuit in triac will destroy the triac, so the device should be short circuit protected to avoid this.

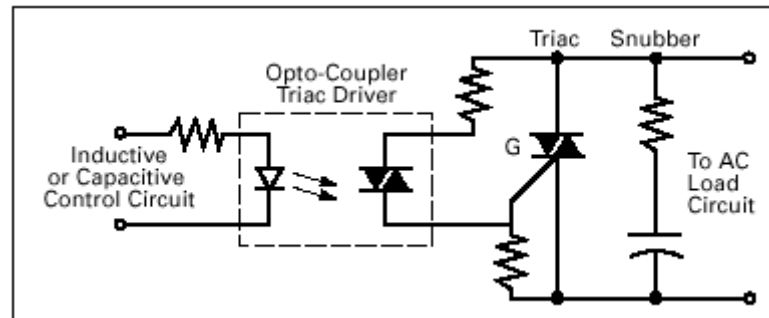

Fig. 5.17 Triac output circuit

Sensor Output Types:

There are mainly three output types: Relay, Traic and Transistor outputs.

3. A Transistor Output: It is also solid state device designed to control DC current. There are mainly two types of circuits depending on the switching function:

NPN (Current Sink) open collector; Here the output transistor is connected to the negative DC. Current flows from the positive terminal through the load, to the sensor, to the negative terminal. **The sensor “sinks” the current from the load,** as shown Fig. 5.18.

PNP (Current Source); the sensor is connected to the positive DC and current flows from the positive terminal through the sensor, to the load, to the negative terminal. **The sensor “sources” the current to the load.**

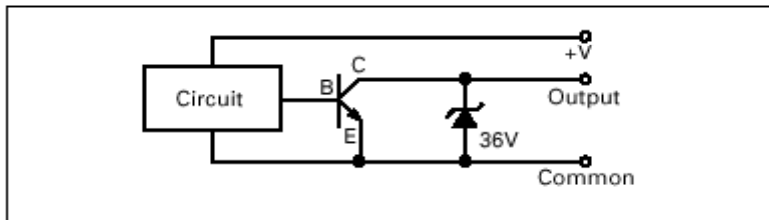

Fig. 5.18 Transistor output circuit (Sinking type).

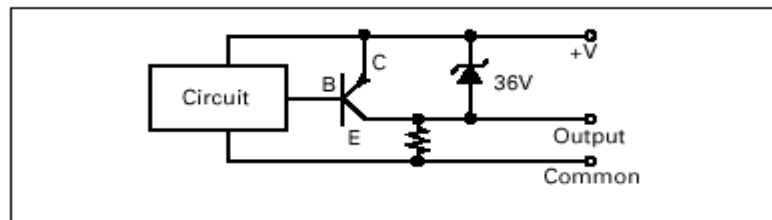

Fig. 5.19 Transistor output circuit (Current Source).

Problems

5-1) Complete the following statements:

Sensors can detect theor Of objects. (ans: presence,absence)

The three main sensor categories are:,, (ans: contact switches, proximity sensors, photoelectric sensors).

The sensor type that can only detect metallic objects is the sensor (ans: inductive type)

The sensor type that uses a broken beam of light to detect objects is commonly referred as a sensor. (ans: photoelectric type).

Inductive proximity sensors work best with metals. (ans: Ferrous)

The transparency of the container has no effects on the sensing of sensors. (ans: Capacitive)

The initials designating a transistor output that sinks current from the load are
(ans: NPN)

The initials designating a transistor output that sources current to the load are
(ans: PNP)

5-2) State the main difference between the electromechanical and solid-state relays, what are the advantages and Drawbacks of both devices?

5-3) What are the differences between Load-Power Sensors and Line-Powered Sensors?

5-4) State the main difference between NPN and PNP sensor output signals, sketch the two output circuits?