

# Chapter 9

## Illustrated Industrial Automation Applications

- 9.1 Machine tool automation problem (drilling process automation).
- 9.2 Metal forming process (forming a simple clip using multiple-slide pressing machine).
- 9.3 Process assembly automation.
- 9.4 Volumetric filling automation system (chemical/food Industries)

## 9.1 Machine tool automation problem (Drilling Process Automation)

### Conventional Drilling Process.

In production lines, drilling units are used where mass production is required. Multi-spindle head sometimes is used to increase the production rate, see Fig. 9.1b. Furthermore, pneumatic or hydraulic power fixture is used to clamp the work piece and holding drilling bushes to reduce the labor cost, see Fig. 9.2.

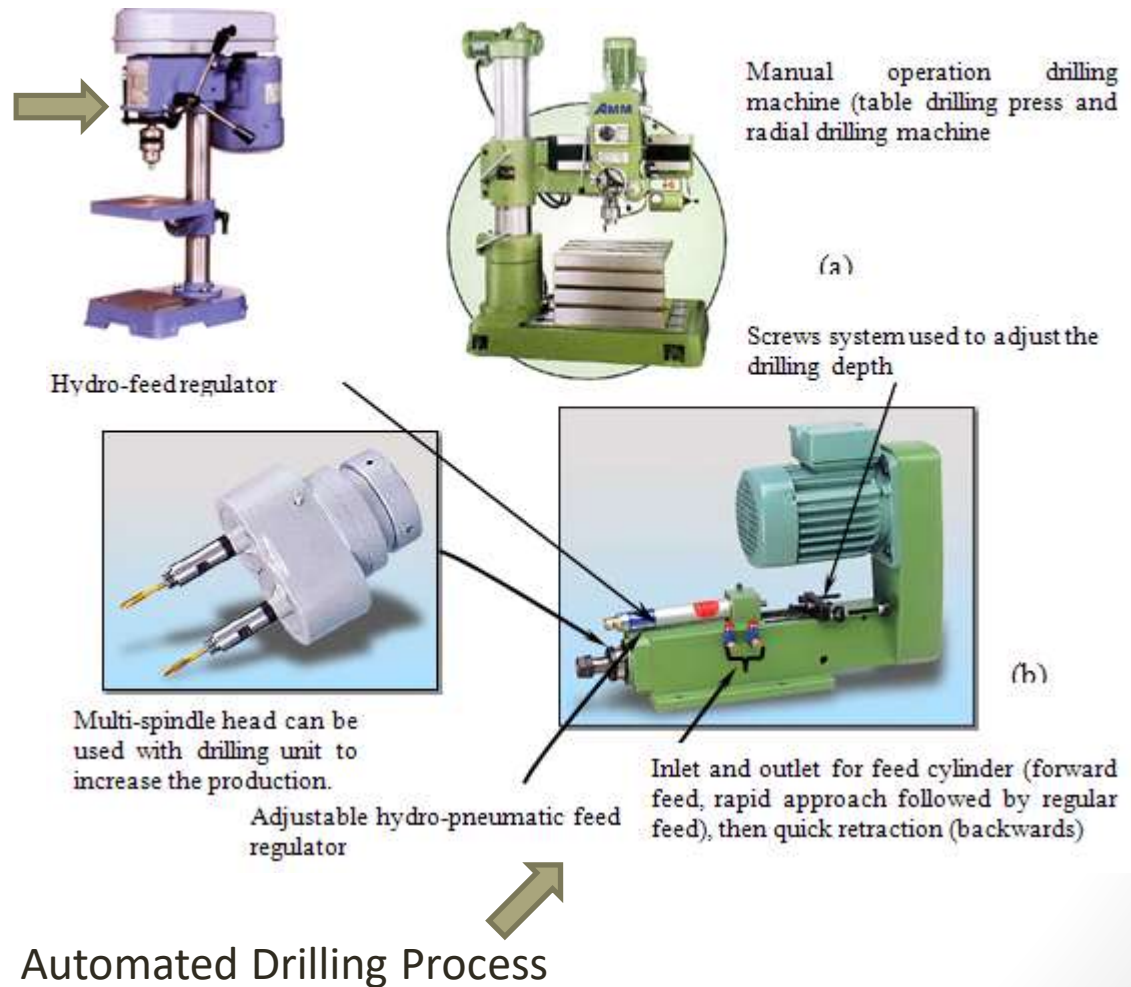

## 9.1 Machine tool automation problem (drilling process automation)

In hole production, drilling operations Three steps using the drilling unit.

- 1. Rapid approaching** of the drilling bit is carried out using pneumatic (or hydraulic power for larger drilling capacity) double acting feed cylinder and 5/2 (or 5/3) solenoid valves.
- 2. The regulated feed** is accomplished using adjustable hydro-pneumatic feed devices, which also adjusted longitudinally to the required drilling depth.
- 3. Rapid retraction** is carried out using the feed cylinder by reversing the direction of airflow through the 5/2 or 5/3 solenoid direction valves

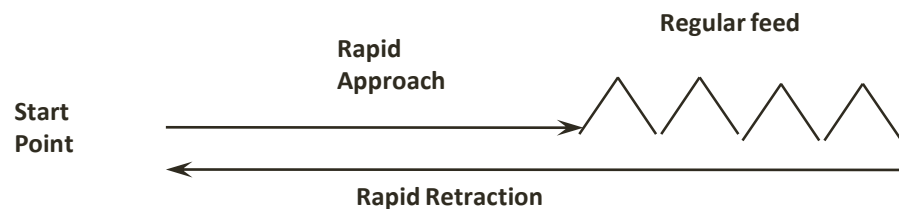
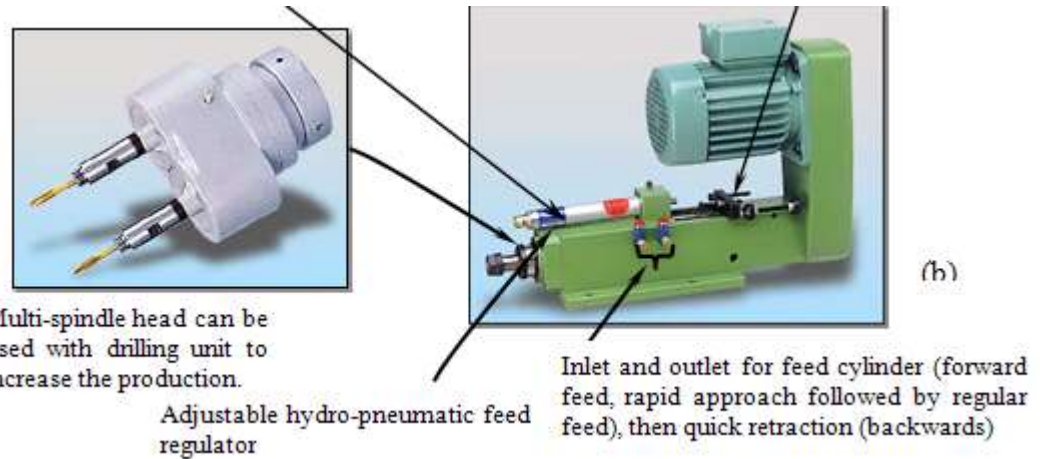

## 9.1 Machine tool automation problem (drilling process automation)

Machine Actuators and Feed-back sensors:

- Two contact limit switches, or reed switches: **Two extreme positions of the feed cylinder.**
- Single phase (or three-phase motor): **Spindle drive**
- Powered drilling fixture: **Clamp and guide the drilling bits through drilling bushes.**  
(Using pneumatic double acting cylinder and through the 5/2 or 5/3 solenoid valve)

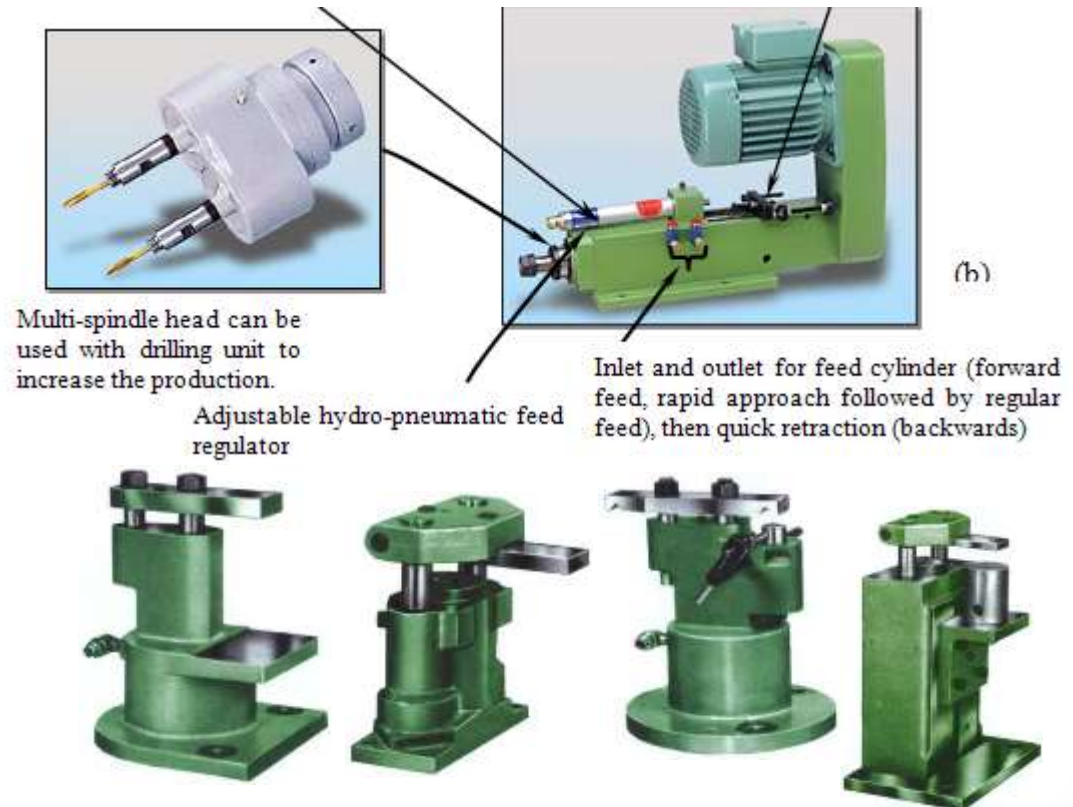

Fig. 9.2 Some powered pneumatic drilling fixtures.

## 9.1 Machine tool automation problem (drilling process automation)

### Machine switching elements and actuators:

Push-button and selector contact switches will be used for machine-user control panel.

Reed or limit switches will be used to monitor the extreme positions of the feed cylinder and clamping fixture-cylinder.

### Suggested machine actuator and machine cycle

Two machine cycles will be used; automatic and manual cycles. Manual cycle will be used during machine setup (i.e. during adjustment of drilling depth). The automatic cycle will be used to carry out the production run. The machine cycle will be written as follows:

*START, M+, B+, A+, A-, M-, B-*.



**Fig. 9.3** Suggested user-panel control and limit contact-switches. (limit switch, push-button switch and selector switch)

<i>M+</i> ; Spindle Motor On	<i>B+</i> ; Clamp the work piece	<i>A+</i> ; Feed cylinder forward toward work piece
<i>M-</i> ; Motor Off	<i>B-</i> ; Unclamp the work piece	<i>A-</i> ; Feed cylinder retract from work piece

## 9.1 Machine tool automation problem (drilling process automation)

**Table 9.1 Suggested switching elements and its functions for drilling control problem.**

Switching element	Symbol	Type	Its function
Start switch	<i>START</i>	Push bottom contact switch	Pressed by the operator to start the automatic machine cycle.
Emergency stop switch	<i>STOP</i>	Push bottom contact switch	Pressed by operator for emergency condition
Manual/Automatic selector switch	<i>Man/Auto</i>	Two position selector switch with two contacts (has mechanical memory)	Selected by operator to switch between automatic and manual cycles
Forward position of the feed cylinder	<i>.a+</i>	Reed or limit contact switch	To monitor drilling depth and used to adjust the drilling depth
Backward position of the feed cylinder	<i>.a-</i>	Reed or limit contact switch	Used to monitor the backward position of the feed cylinder
Monitor clamping switch	<i>.b+</i>	Reed or limit contact switch	Used to monitor the clamping condition of the work piece
Monitor unclamping switch	<i>.b-</i>	Reed or limit contact switch	Used to monitor the unclamping condition of the work piece
Manual feed switch	<i>Man a+ / Man a-</i>	Three position selector switch with two contacts and neutral position (with mechanical memory)	Used for manual feeding the drilling unit (forward and backward), used during machine setup
Manual clamping/unclamping the workspace switch	<i>Man b+ / Man b-</i>	Three position selector switch with two contacts and spring return to neutral position (no memory)	Used for manual clamping/unclamping the work piece during machine setup
Manual motor on/off	<i>Man M+</i>	Two position selector switch one contact (with mechanical memory)	Used for manual switching on/off the spindle motor

Where:

Development of RLL for the given machine sequence:

The machine sequence can be grouped using CASCAD method and given as follows

$START, M+, B+, A+, A-, M-, B-$   
 ... Group 1 | ... Group 2

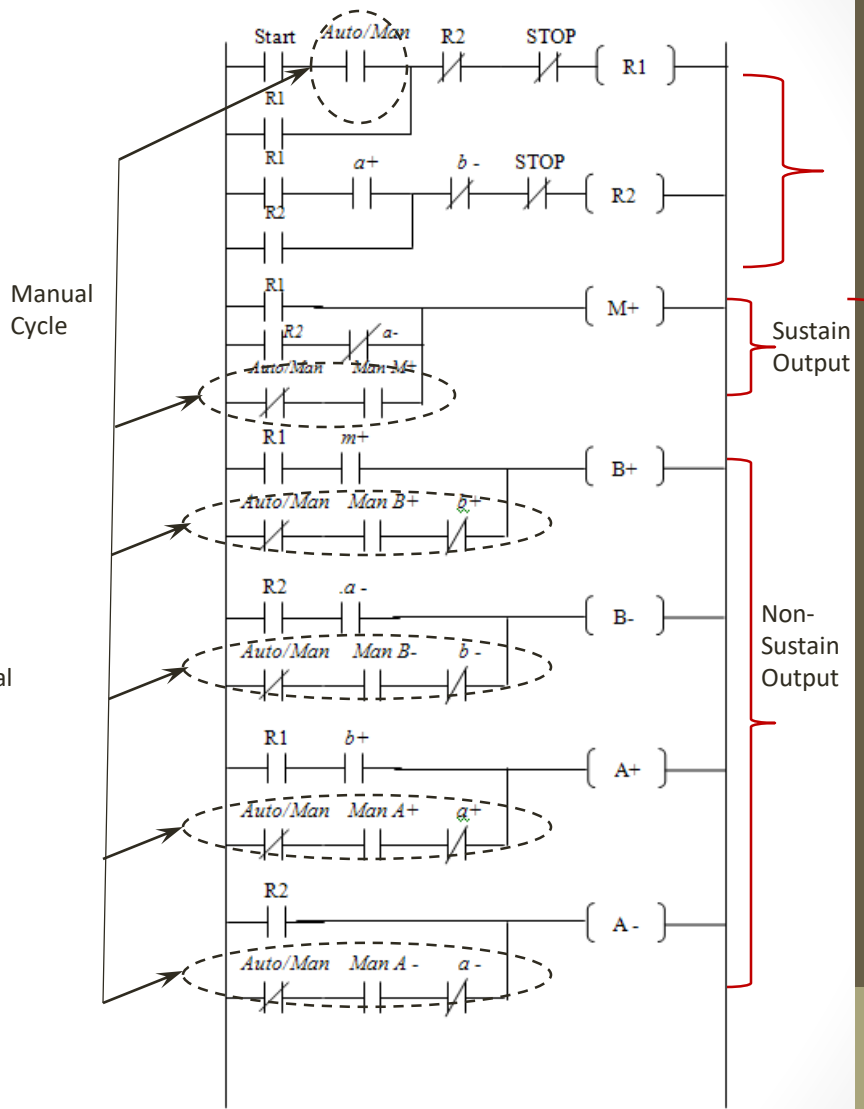
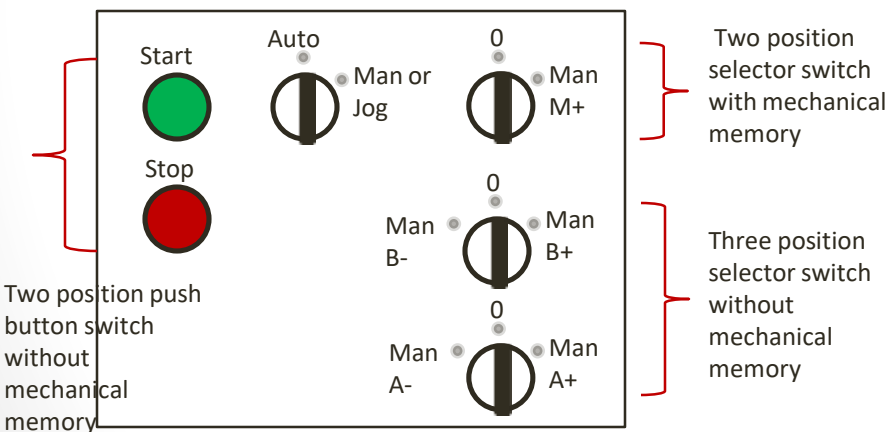

Fig. 9.3 Developed RLL for drilling process automation.

Where:

### 9.3 Process assembly automation : Insulation Paper Cutting Machine

#### Machine Function

The insulation paper is supplied as roll strip to machine rack where pulled out using feeding mechanism longitudinally. At the end of feeding stroke, cutting plad mechanism is used to cut the paper to the specified paper length. As protection for machine structure, the machine will not operate if no paper stock on the paper moving mechanism through an optical sensor SW1.

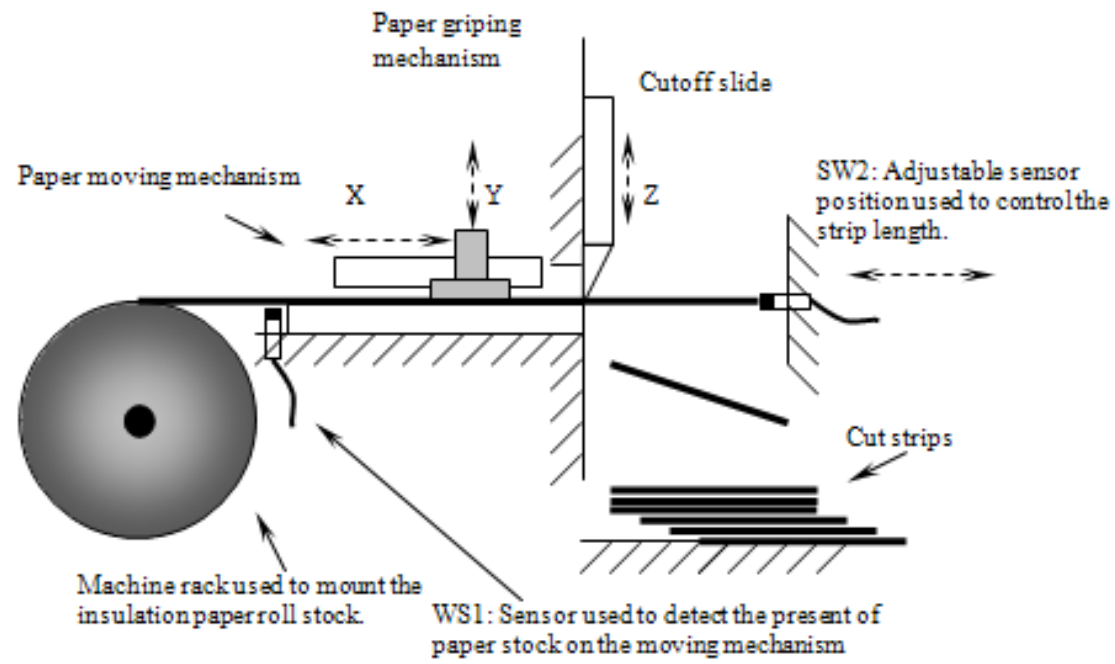
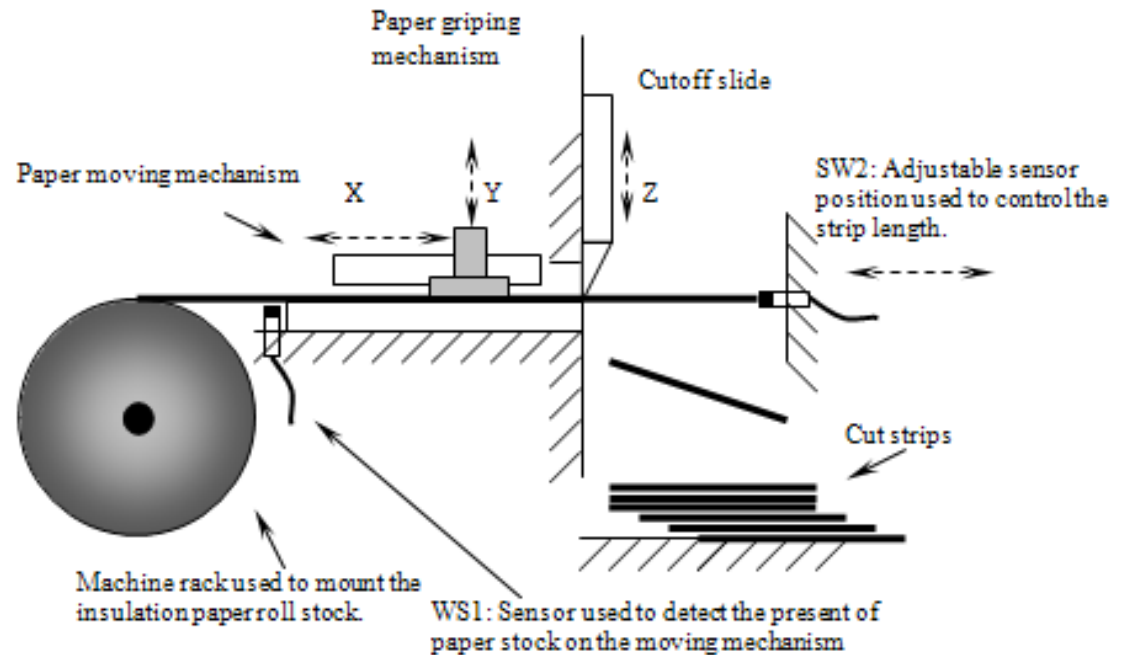

Fig.9.7 Paper cutting assembly machine.

### 9.3 Process assembly automation : Insulation Paper Cutting Machine

Summary of machine cycle is given as follows:

1. Gripping paper stock : Pneumatic cylinder Y+.
2. Forward movement of paper stock: moving mechanism through pneumatic cylinder X+, where 5/3 directional valve is used to actuate cylinder X.
3. Optical sensor SW2: detect the position of paper strip when reach the specified length.
4. Cutoff mechanism : cutoff slide using pneumatic cylinder Z+.
5. Simultaneously cutoff slide will retract to its original position (Z-).
6. Releasing paper stock by retracting gripping cylinder (Y-).
7. Back movement for stock moving mechanism using cylinder (X-).
8. End.
9. Repeat when needed



**Fig. 9.7** Paper cutting assembly machine.

Where:

### 9.3 Process assembly automation : Insulation Paper Cutting Machine

These cutting processes can be repeated for a given number of cutting stripes.  
 Machine cycle can be written as follows:

*START, Y<sup>+</sup>, X<sup>+</sup>, Z<sup>+</sup>, Z<sup>-</sup>, Y<sup>-</sup>, X<sup>-</sup>.*

*START, Y<sup>+</sup>, X<sup>+</sup>, Z<sup>+</sup>, Z<sup>-</sup>, Y<sup>-</sup>, X<sup>-</sup>.*

G1 | G2

RLL for cutting single paper stripe is given as follows:

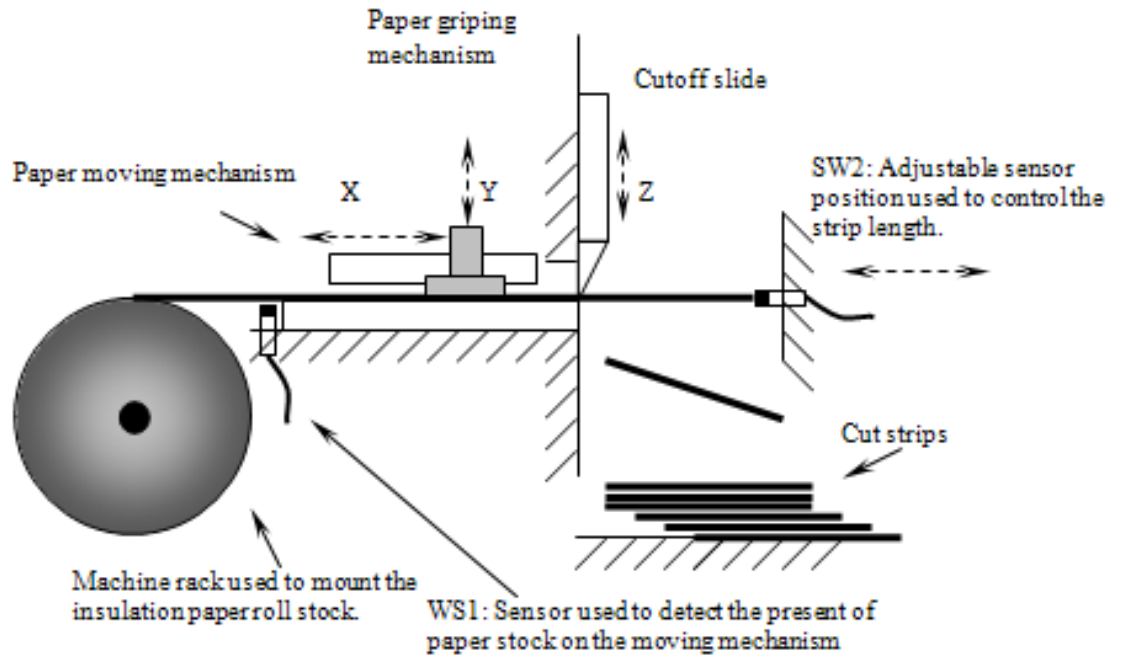

**Fig. 9.7** Paper cutting assembly machine.

### 9.3 Process assembly automation : Insulation Paper Cutting Machine

RLL for cutting single paper stripe is given as follows:

$START, Y^+, X^+, Z^+, Z^-, Y^-, X^-$ .

G1 | G2

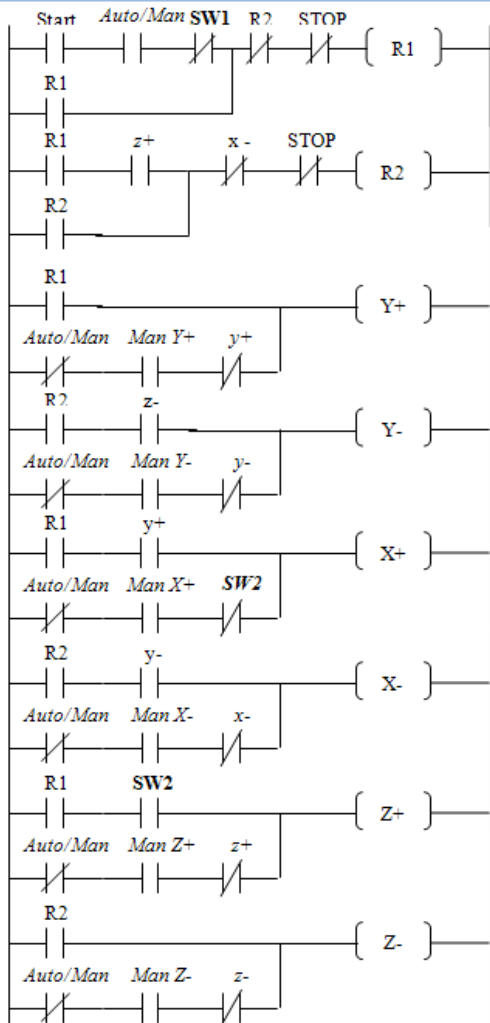

SW1 is used here to disable the machine operation in no paper stock is exist.

SW2 switch is used here to provide actual feed back signal on reaching the exact strip length.

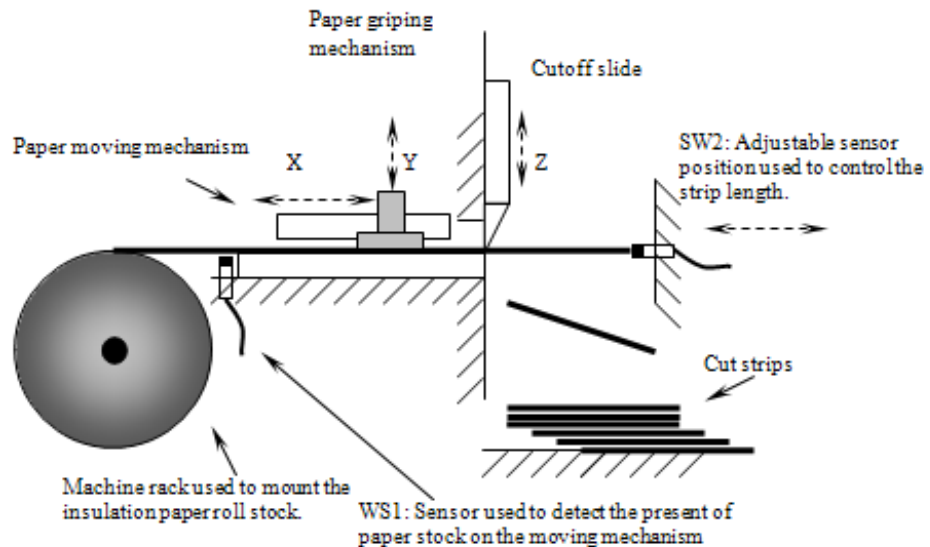

Fig. 9.7 Paper cutting assembly machine.



## 9.4 Volumetric filling automation process

### 9.4.1 Machine Processes:

3) Hooper Filling Process

1) Volumetric Pump Process

2) Conveyor Process.

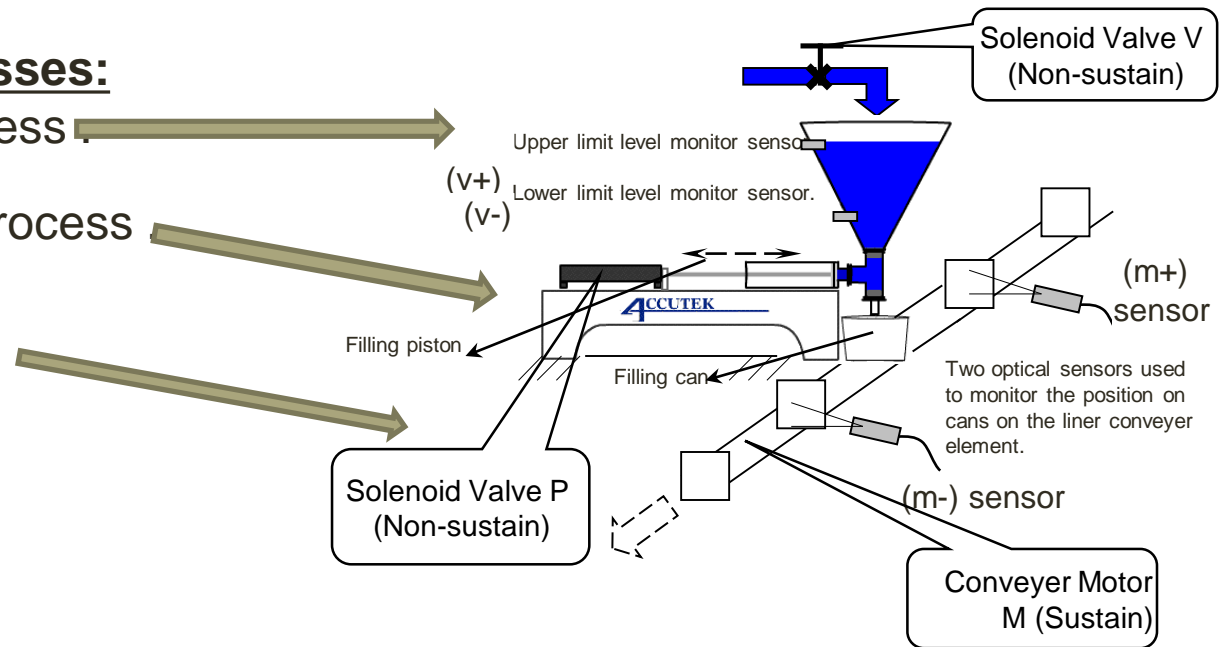





## 9.4 Volumetric filling automation process

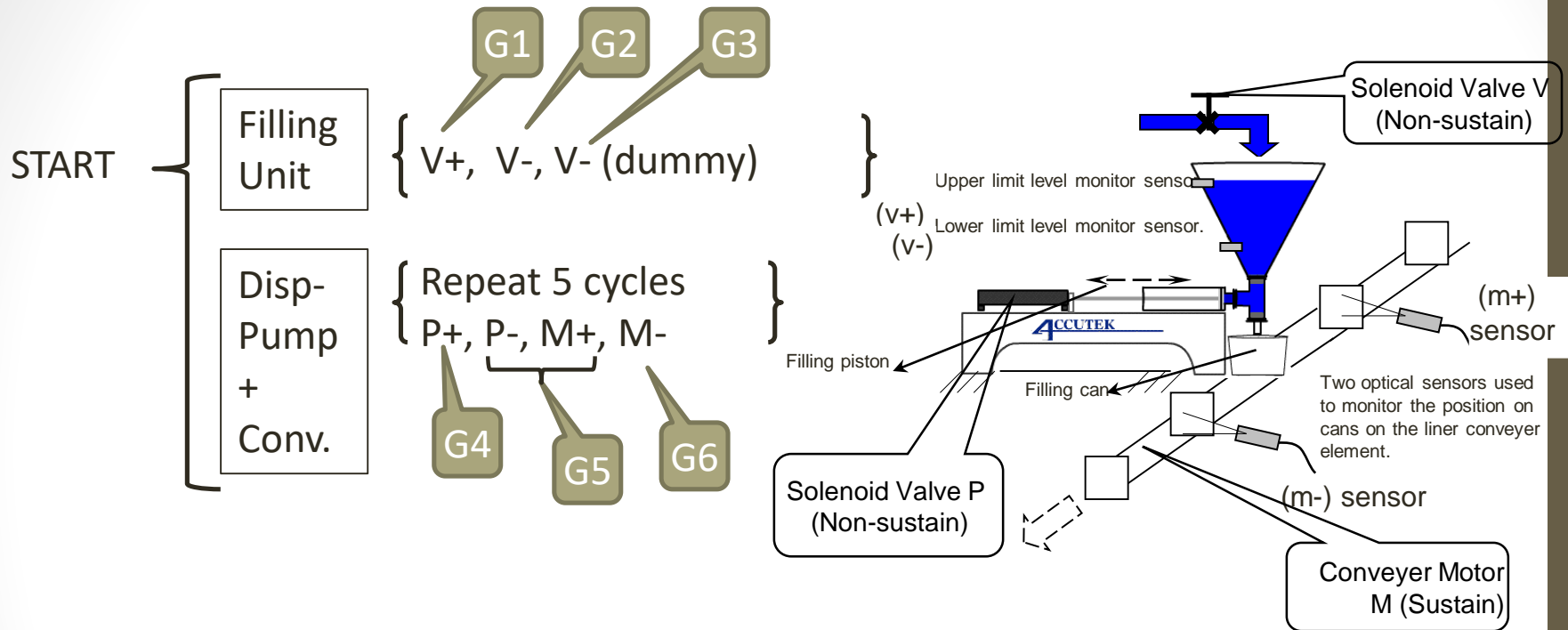

### 9.4.2 Control Strategy :

- The Hooper Filling Process will be effected as long the two processes (volumetric pump + conveyor) is enabled. (Parallel process)
- Volumetric pump and conveyor will run together in series. (Single path).

## 9.4 Volumetric filling automation process

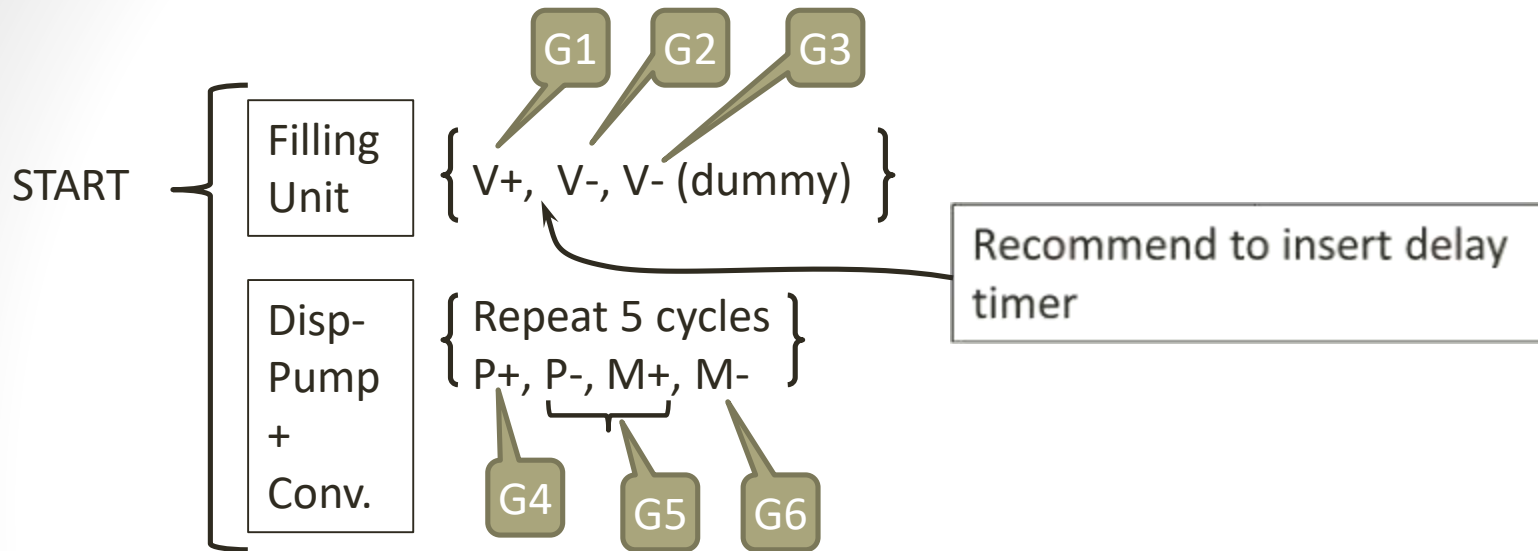

### 9.4.2 Control Strategy :

- The Hooper Filling Process will be effected as long the two processes (volumetric pump + conveyor) is enabled. (Parallel process)
- Volumetric pump and conveyor will run together in series. (Single path).

## 9.4 Volumetric filling automation process

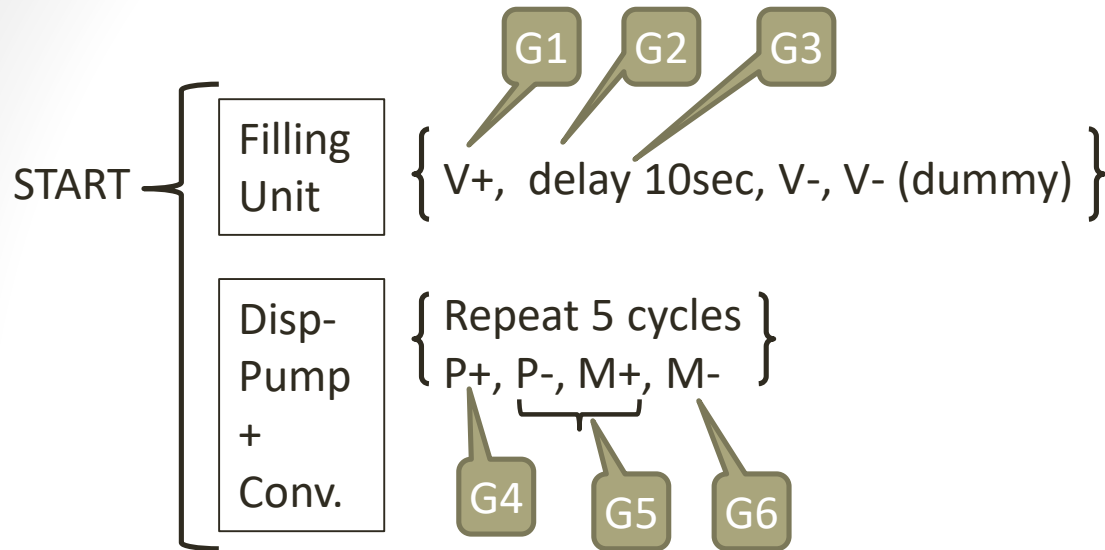

### 9.4.2 Control Strategy :

- The Hooper Filling Process will be effected as long the two processes (volumetric pump + conveyor) is enabled. (Parallel process)
- Volumetric pump and conveyor will run together in series. (Single path).

# 9.4 Volumetric filling automation process

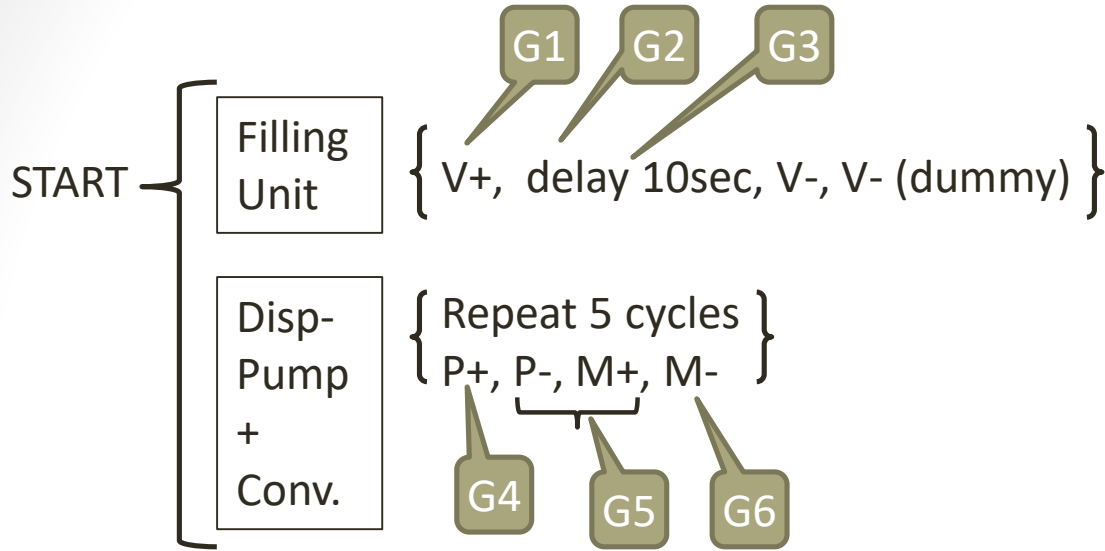

Filling Unit RLL

9.4 Volumetric filling automation process

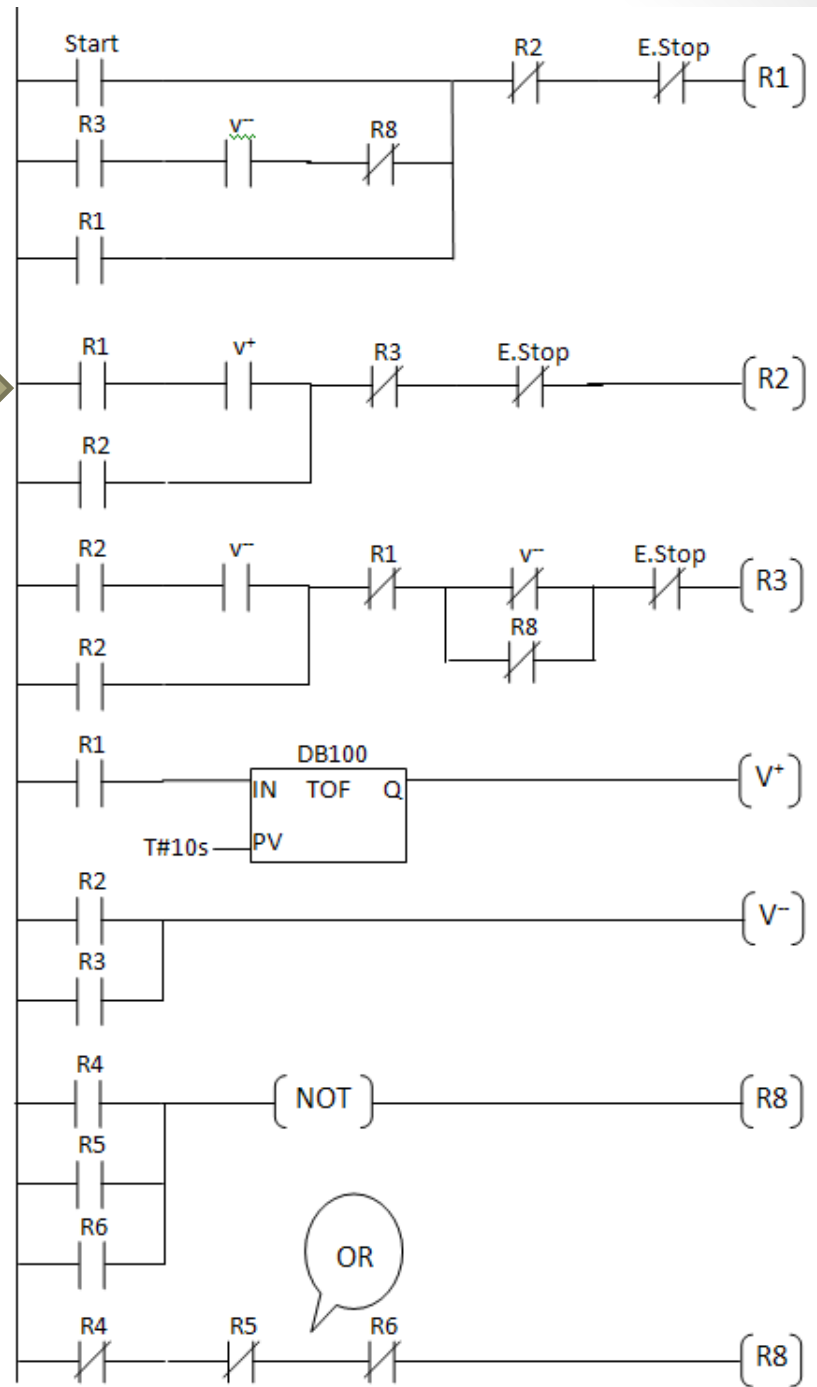
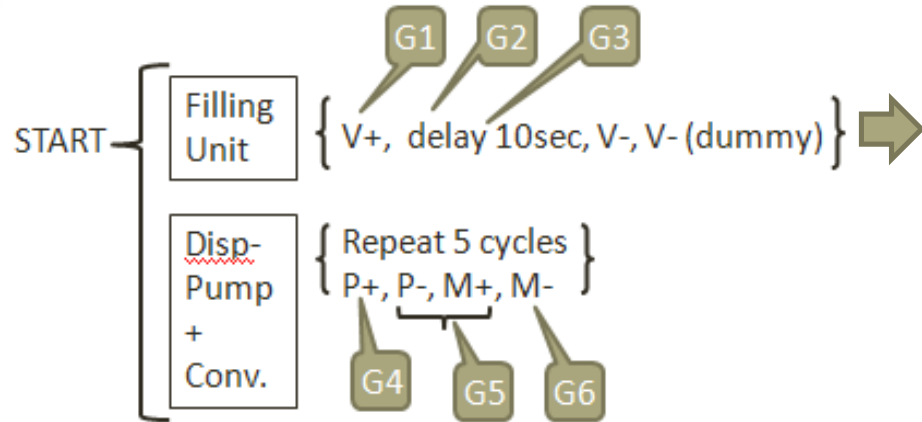

*Displacement Pump + Conveyor Unit RLL*

9.4 Volumetric filling automation process

