

Chapter 2

Programmable Logic Controller (*PLC*) and Relay Ladder Logic (*RLL*).

- 2.1 *PLC* Operation using scanning technique.
- 2.2 Understanding Relay Ladder Diagram (*RLL*).
- 2.3 Basic Instructions of *RLL*.
- 2.4 Motor control using *PLC*, two push buttons and motor starter.
- 2.5 Adding two indicators for the developed *RLL*.
- 2.6 *PLC* Programming.

2.1 PLC Operation using scanning technique

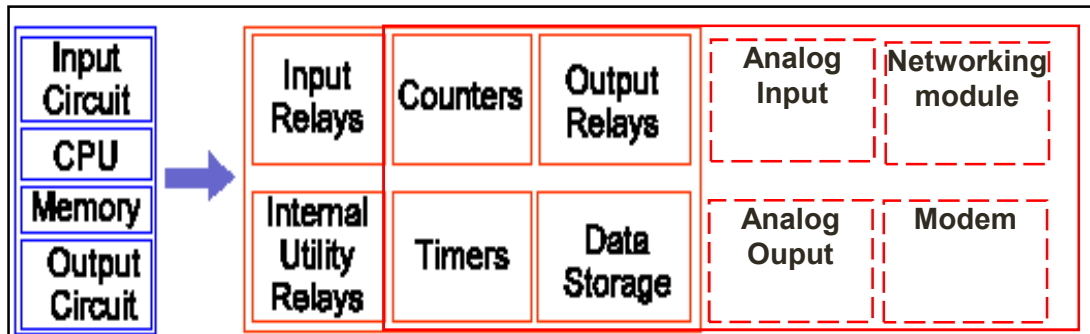

Fig. 2.1 Internal structure of a PLC.

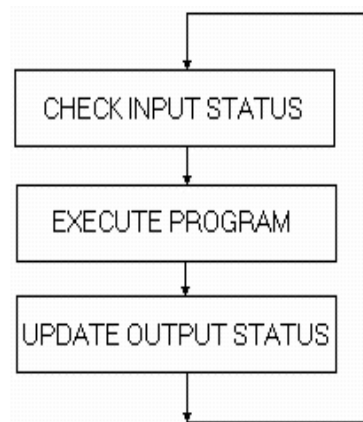

Fig. 2.3 Scanning technique in PLC.



2.1 PLC Operation using scanning technique

Two modes of operations:

1. Programming mode.
2. Automatic or running mode(scanning mode)

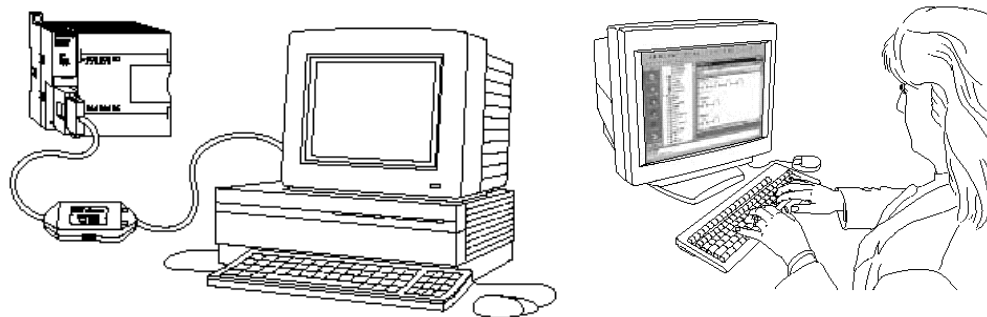

Fig. 2.16 PLC Programming technique using PC computer through serial port.



2.2 Understanding Relay Ladder Diagram (RLD)

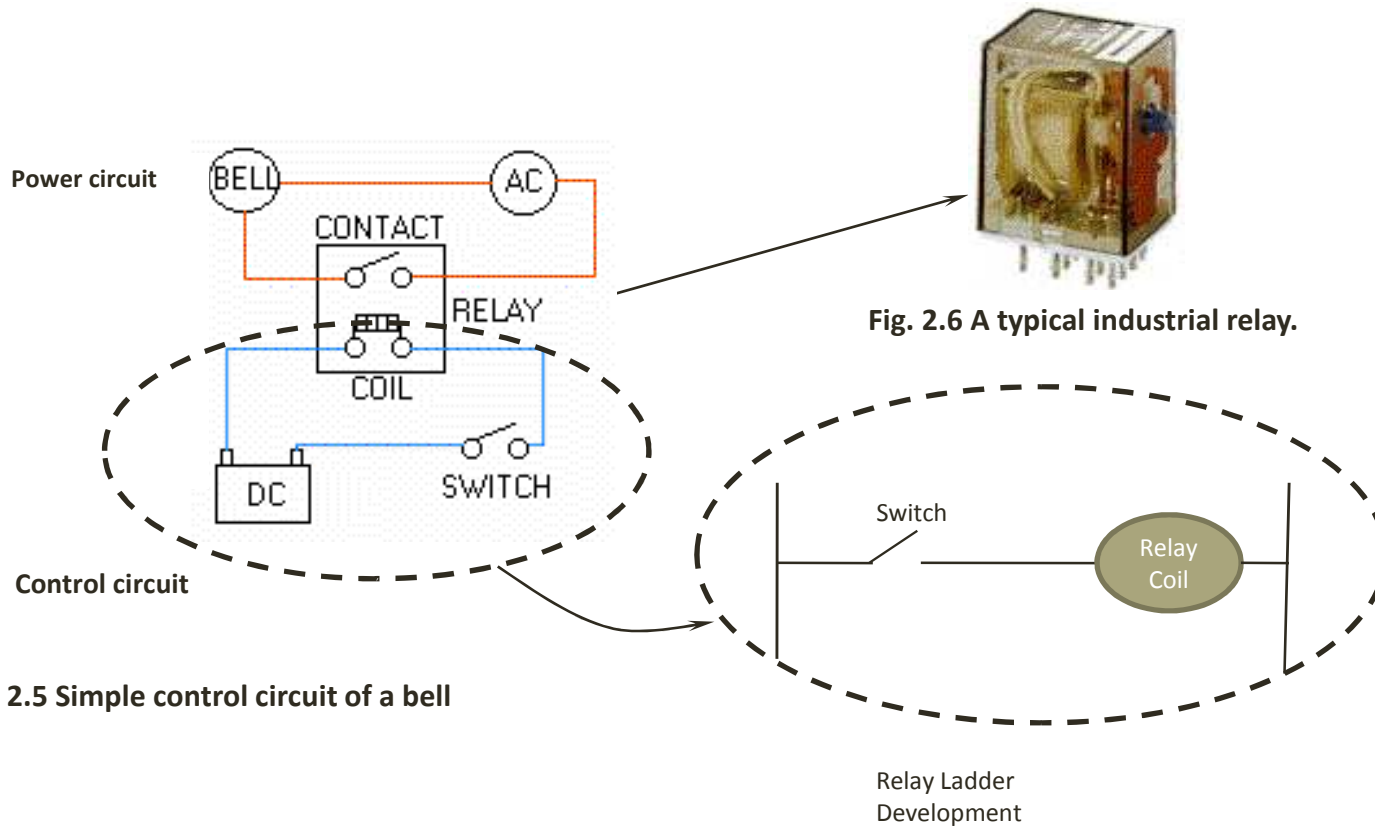

Fig. 2.5 Simple control circuit of a bell

Fig. 2.6 A typical industrial relay.

Relay Ladder
Development

2.2 Understanding Relay Ladder Diagram (RLL)

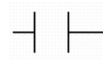

Fig. 2.7 Contact relay symbol (RLL).

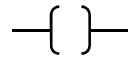

Fig. 2.8 Output relay symbol (RLL).

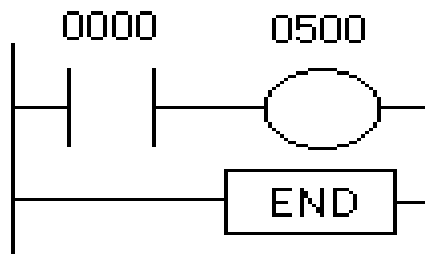
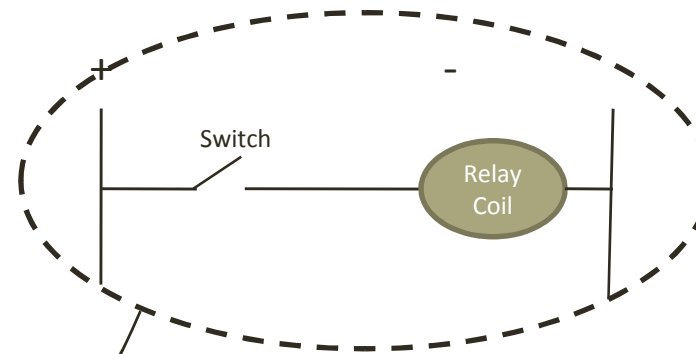

Fig. 2.9 RLL for bell control circuit.



Relay Ladder
Development

Main input instructions

Normally open contact :



Normally closed contact :

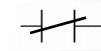

Main output instructions

Normally open relay

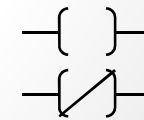

Normally closed relay

2.3 Basic Instructions of RLL

Some simple illustrated RLL circuit

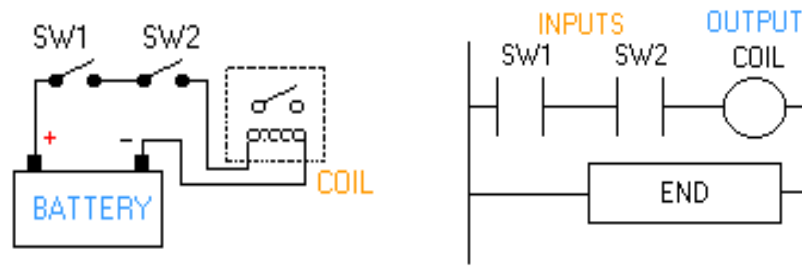

Fig.2.11 Control and RLL for AND Boolean operation.

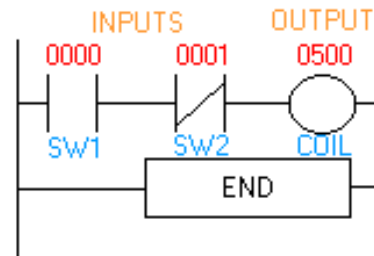

Fig. 2.12 Amended RLL using Normally closed switch for switch SW2.

The Boolean logic equation will be : $Coil = SW1 \cdot \overline{SW2}$

2.4 Motor control RLL network, two push buttons and motor starter

Here two push buttons switches (Start/Stop) are used to switch the motor on/off. These switches are connected to the two PLC inputs discrete type), as shown in Fig. 2.13.

One of the output ports (discrete outputs) of the PLC used to switch motor starter on/off, which will start/stop the electric motor.

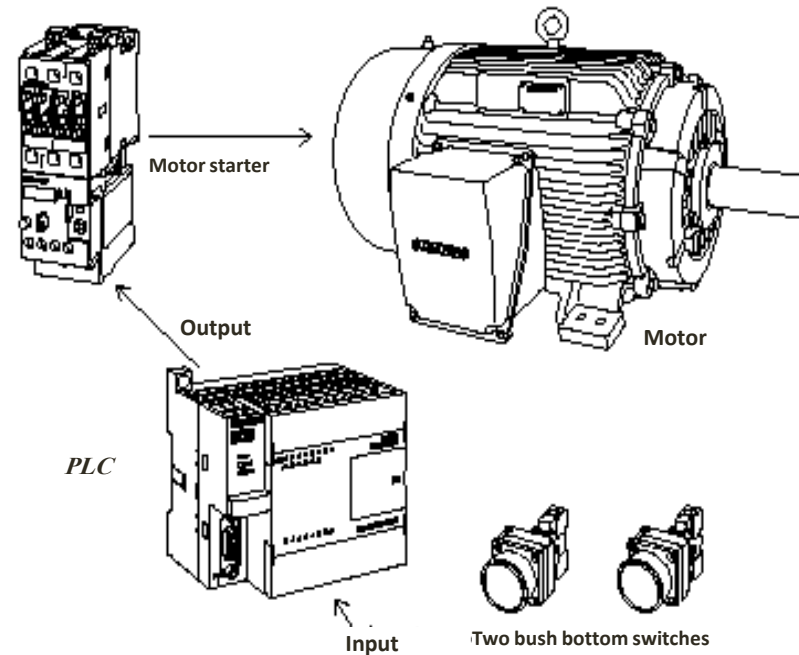
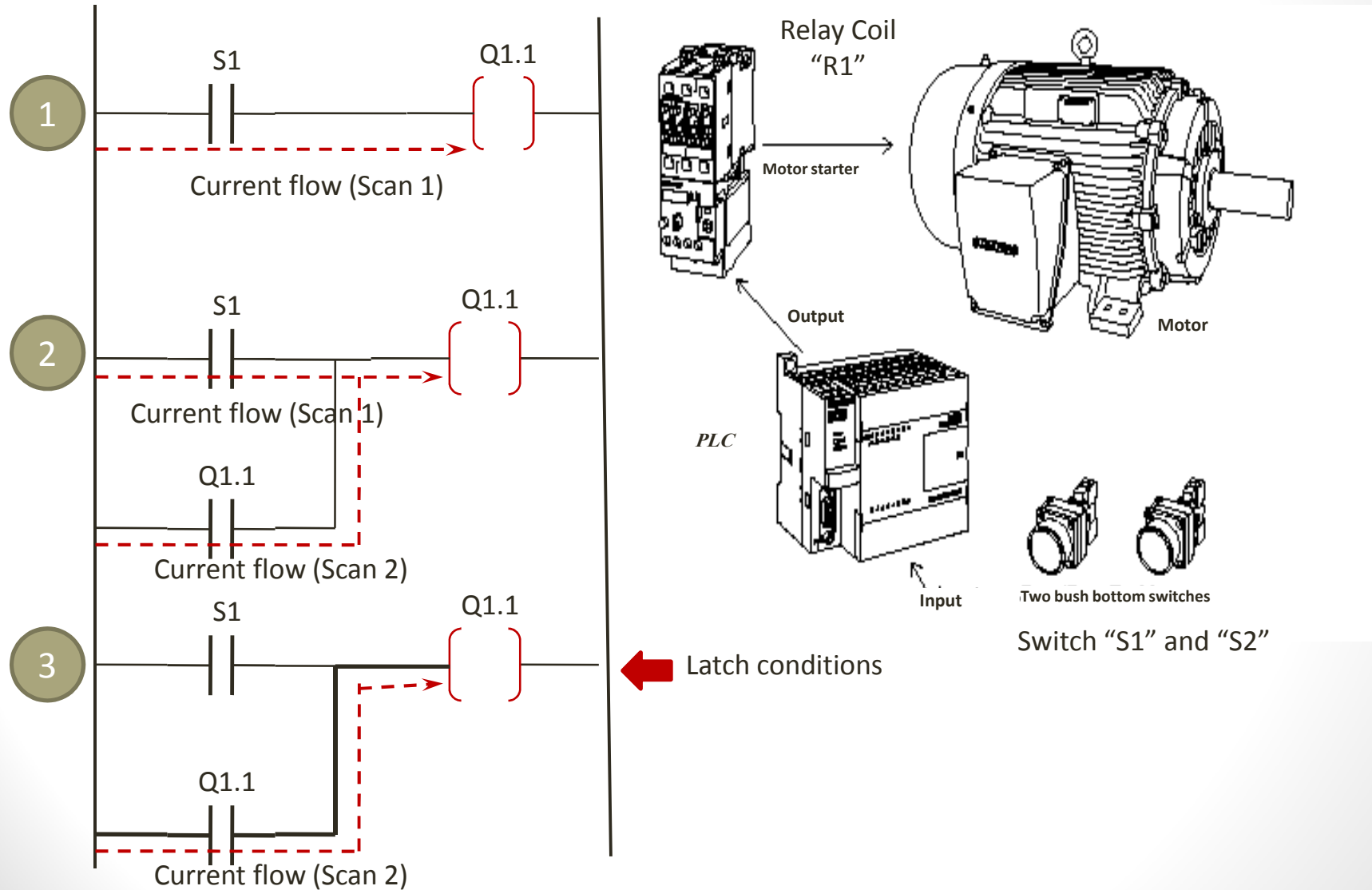
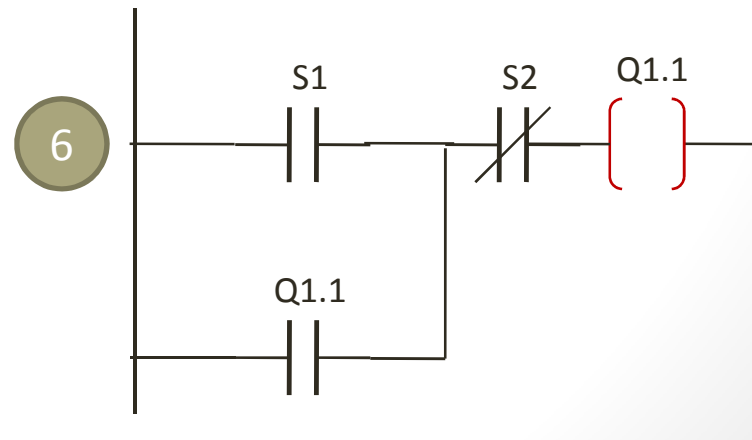
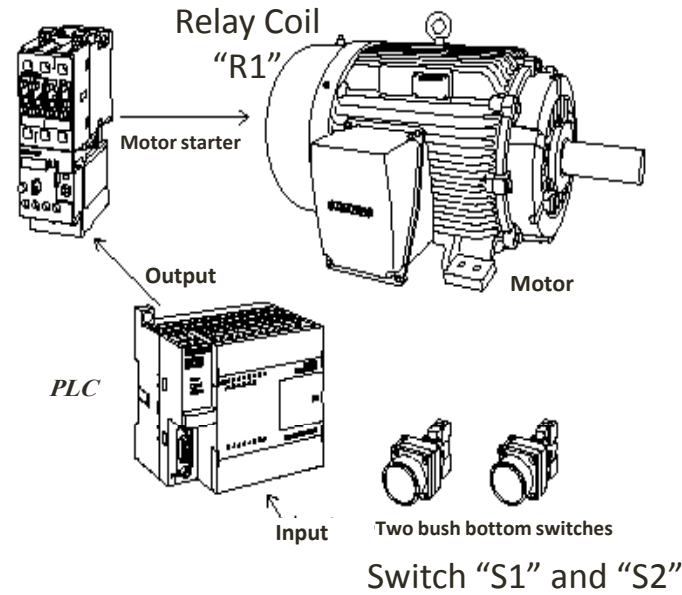
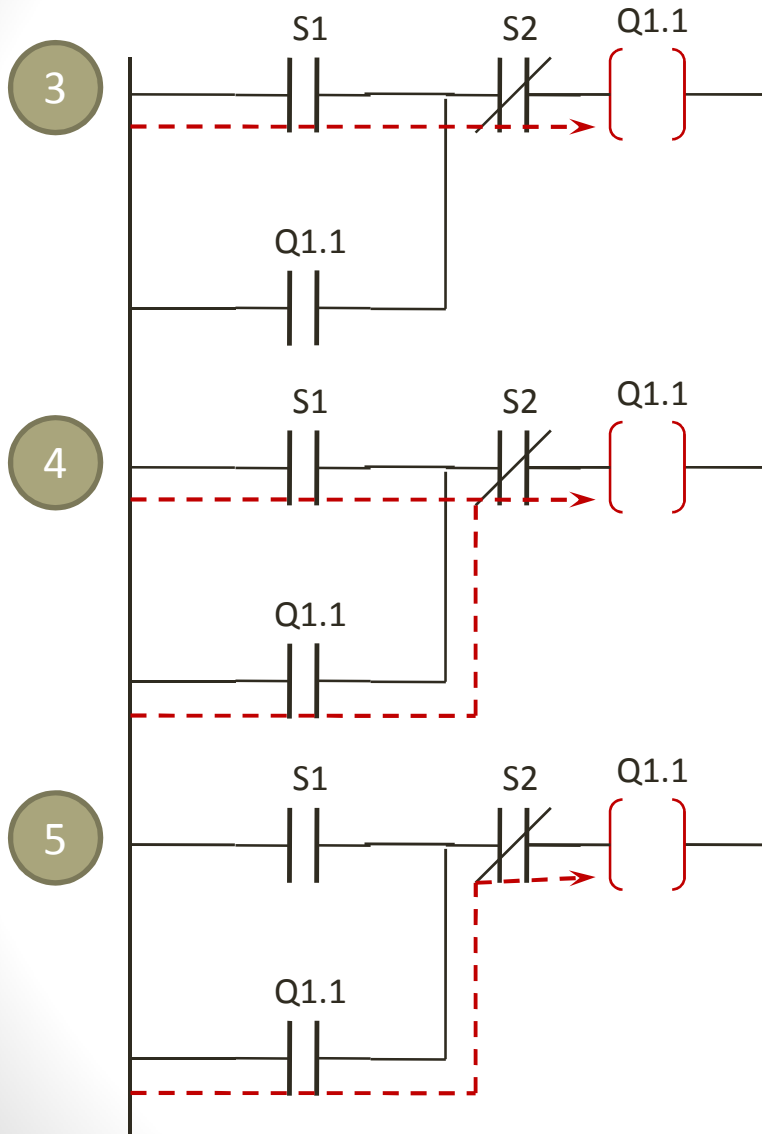

Fig. 2.13 Motor control using PLC, motor starter and two push buttons.

2.4 Motor control RLL network, two push buttons and motor starter



2.4 Motor control RLL network, two push buttons and motor starter



2.5 Motor control RLL network, two push buttons and motor starter Adding Two Indicators Green (G) and Red (R)

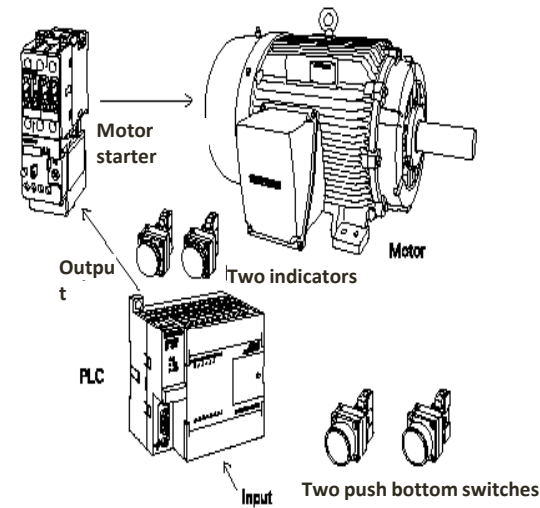
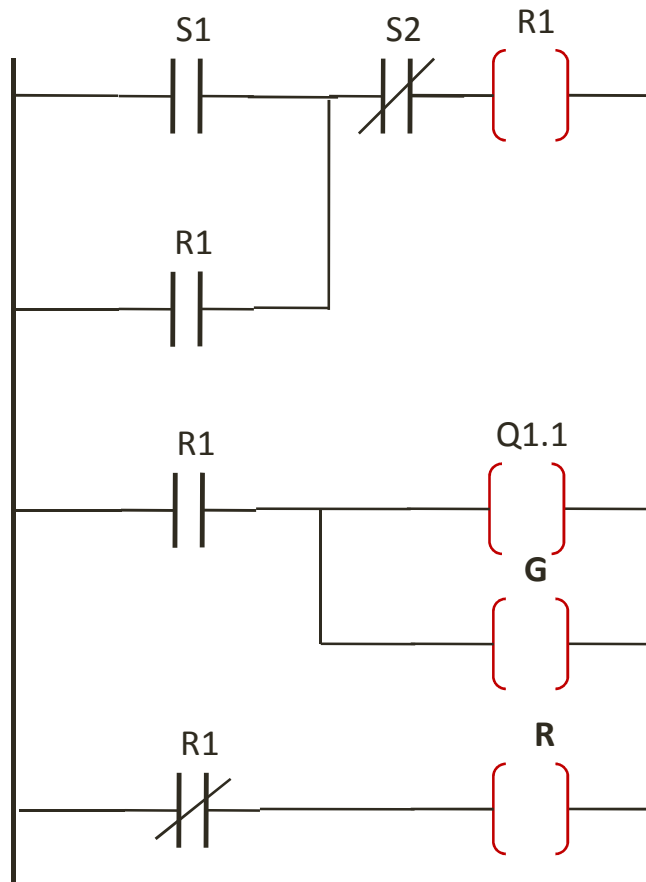

Fig. 2.15 Amended *RLL* for motor control after adding two indicators.

2.5 Motor control RLL network, two push buttons and motor starter Adding Two Indicators Green (G) and Red (R)

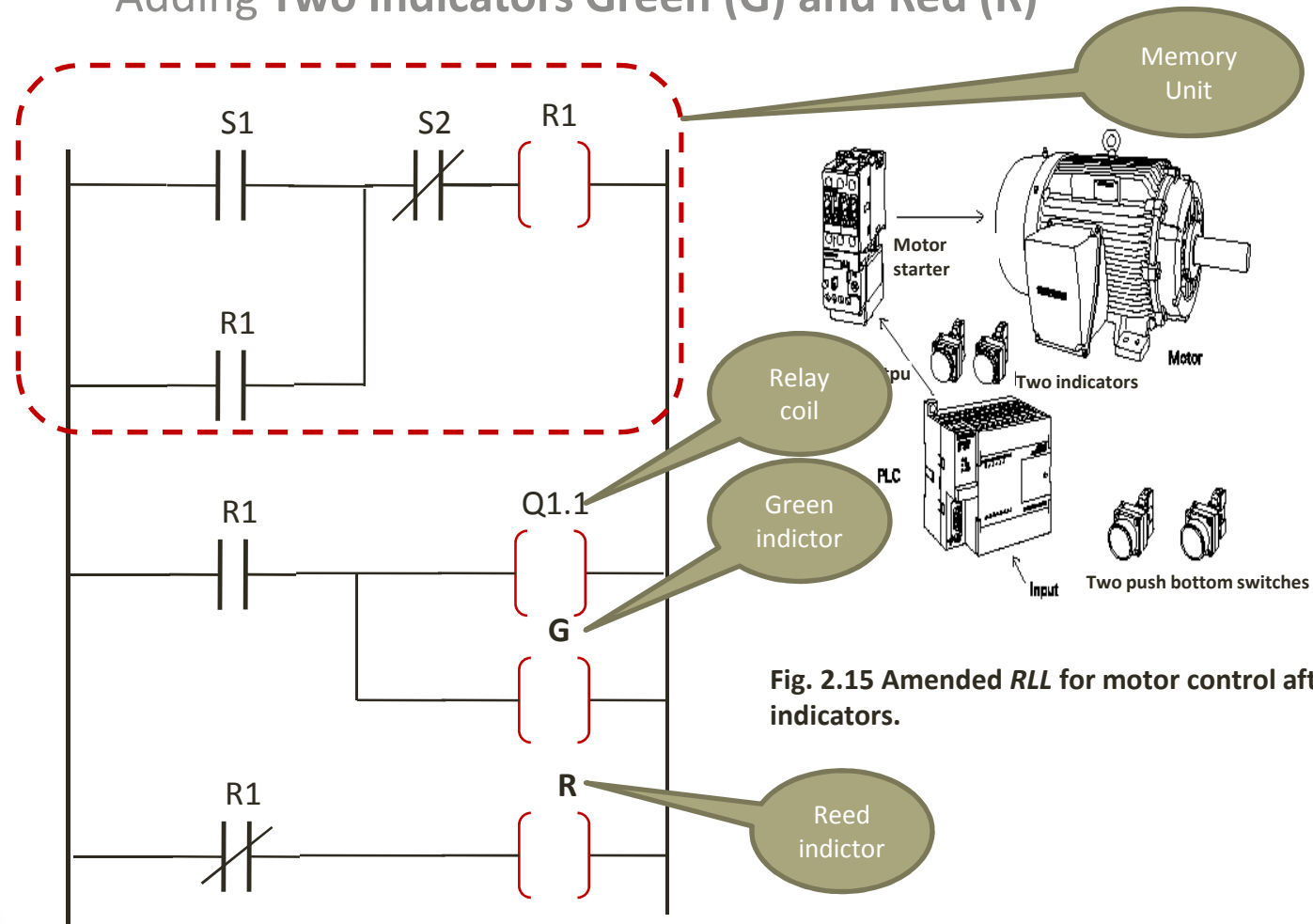

Fig. 2.15 Amended RLL for motor control after adding two indicators.

2.5 Motor control RLL network, two push buttons and motor starter

Adding Two Indicators Green (G) and Red (R) + **Overload Switch (OV)**

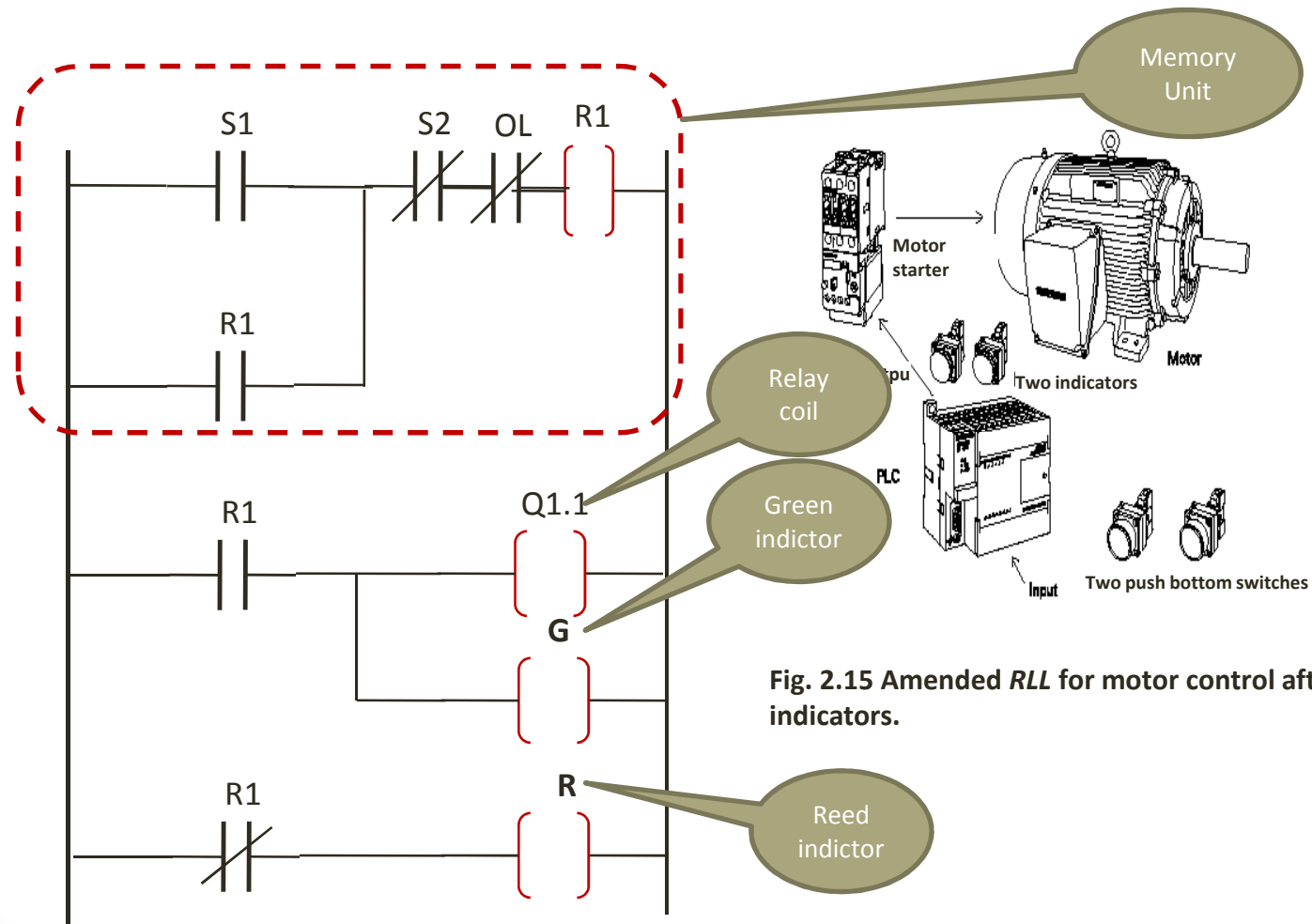
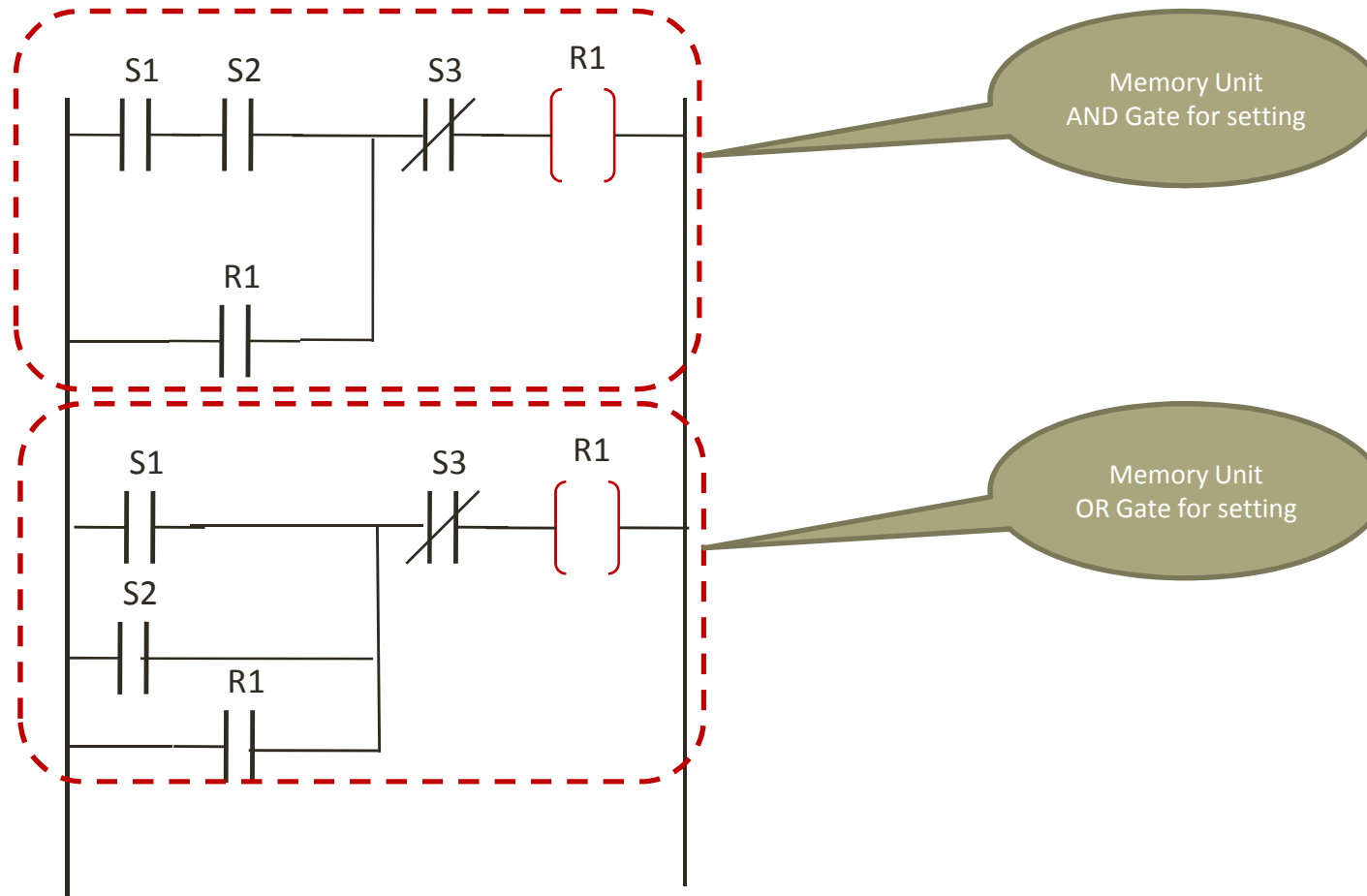
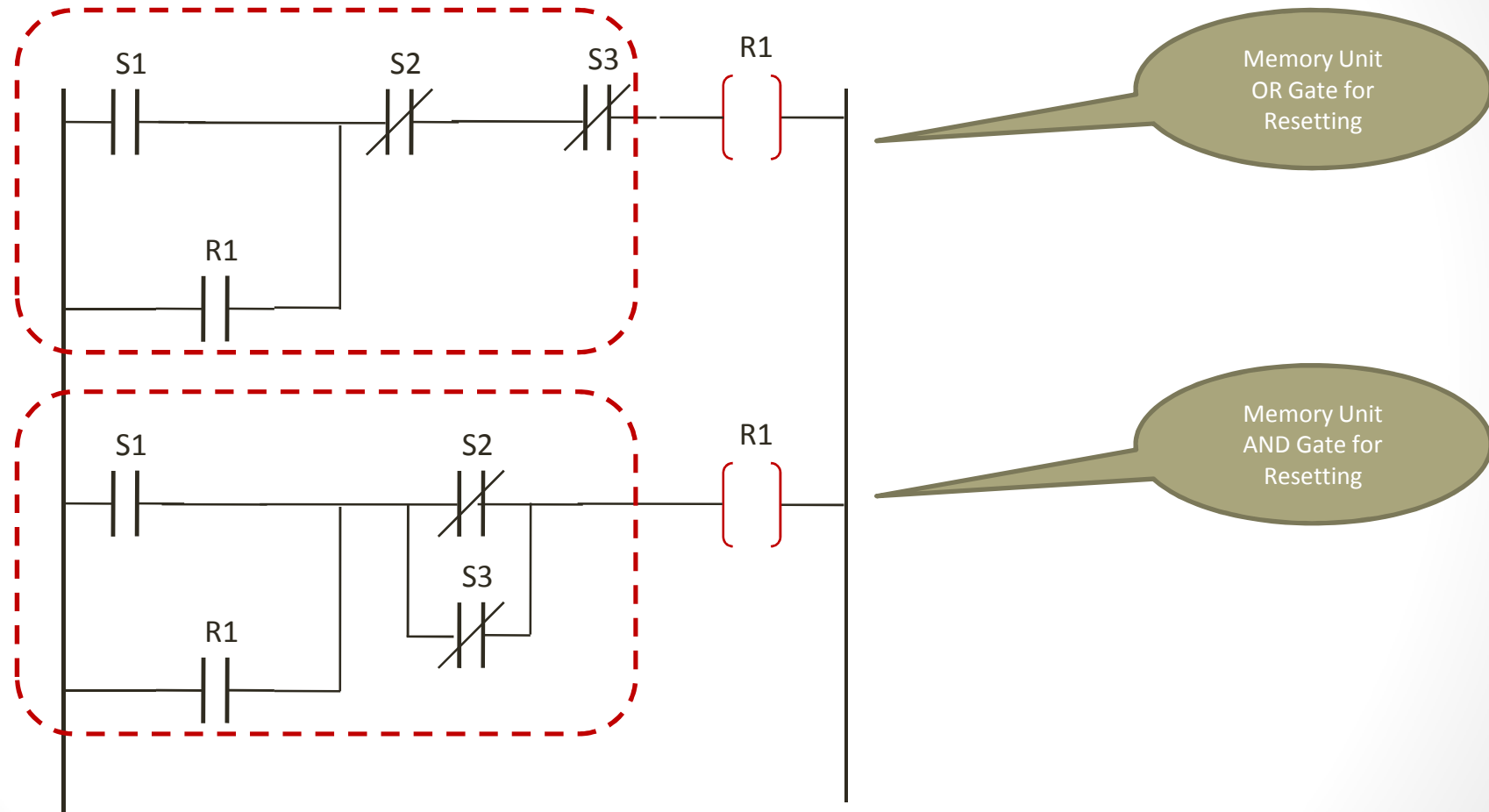

Fig. 2.15 Amended RLL for motor control after adding two indicators.

2.5 Setting and resetting memory elements using AND and OR gates



2.5 Setting and resetting memory elements using AND and OR gates



2.5 PLC Programming and Networks



{ Relay Ladder Logic }

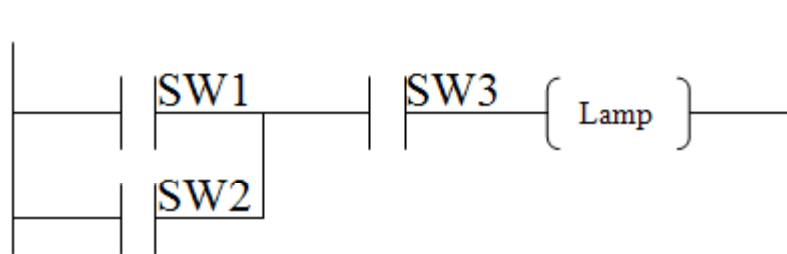

{ Relay Ladder Logic }
LAMP = (SW1 OR SW2) AND SW3
LAMP = (SW1 + SW2) . SW3

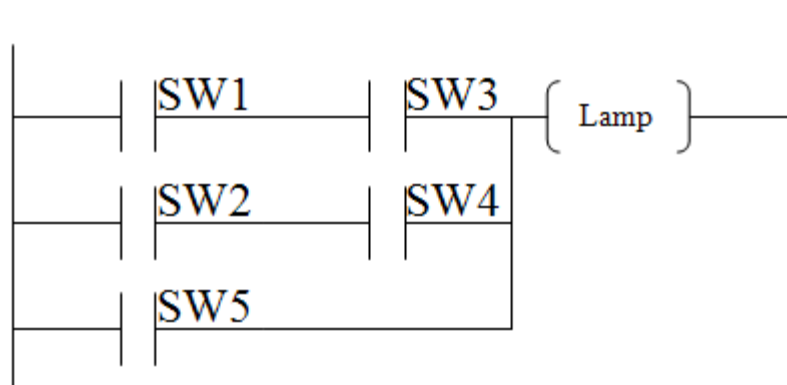

{ Relay Ladder Logic }
LAMP = (SW1.SW3) +(SW2.SW4)+SW5

2.5 PLC Programming and Networks

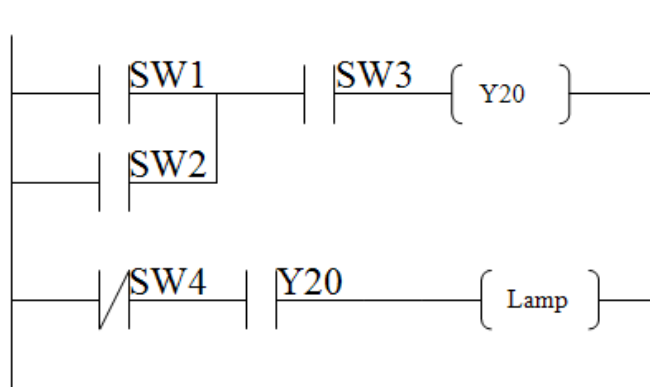

$$Y20 = (\overline{SW1} + \overline{SW2}) \cdot SW3$$

$$LAMP = SW4 \cdot Y20$$

Or

$$LAMP = (SW1 + SW2) \cdot SW3 \cdot \overline{SW4}$$

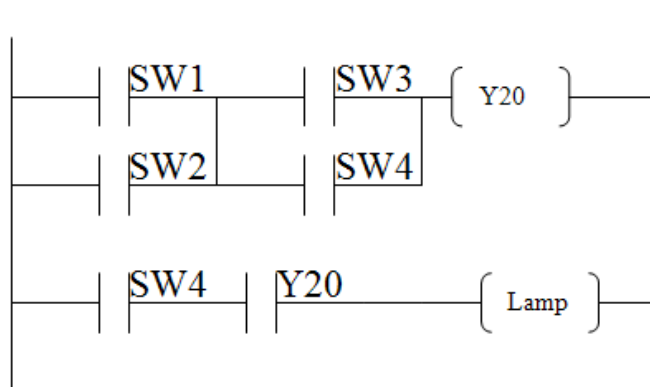

$$Y20 = (SW1 \cdot SW3) + (SW1 \cdot SW4) + (SW2 \cdot SW3) + (SW2 \cdot SW4)$$

$$LAMP = SW4 \cdot Y20$$

Or

$$LAMP = ((SW1 \cdot SW3) + (SW1 \cdot SW4) + (SW2 \cdot SW3) + (SW2 \cdot SW4)) \cdot SW4$$

2.5 PLC Programming and Networks

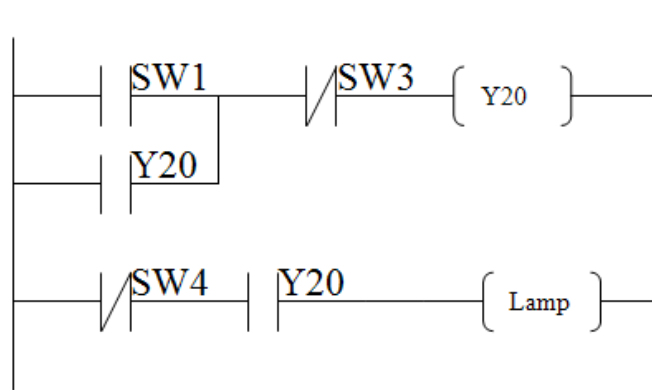

$$Y20 = SW1 \cdot \overline{SW3} + Y20 \cdot \overline{SW3}$$

$$LAMP = \overline{SW4} \cdot Y20$$

Note: 1st Boolean equation is memory flip-flop.

Fig. 2.18 Development of RLL for different control logics

Example 4:

Modify the developed relay-ladder logic given in *example 3* such that the enabled/disabled using external supervisor through switch (SW5) ?

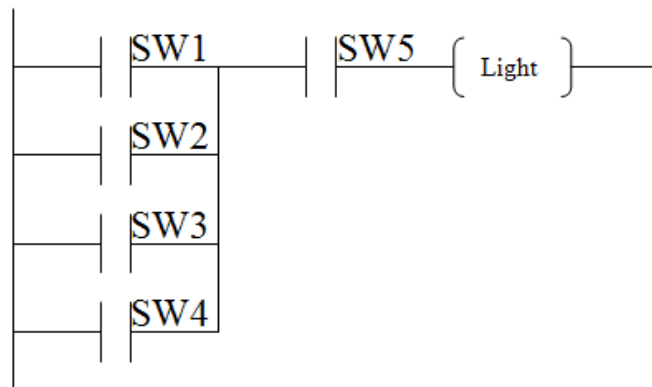

$$LIGHT = (SW1 + SW2 + SW3 + SW4) \cdot SW5$$

PROBLEMS

2.1) Develop the *RLL* diagrams for the following Boolean equations :

- $F1 = A \cdot B + \overline{A} \cdot B$
- $F2 = sw1 \cdot sw2 \cdot sw3 \cdot \overline{sw4}$
- $F3 = (sw1 \cdot sw2 \cdot sw3) + \overline{sw4}$
- $Y = (A \cdot B \cdot C + D) \cdot (\overline{E \cdot F})$

2.2) Drive the Boolean equations for the following relay ladder logics

(a)

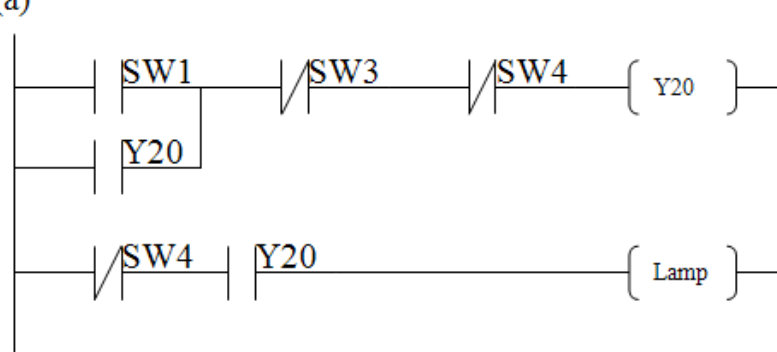

(b)

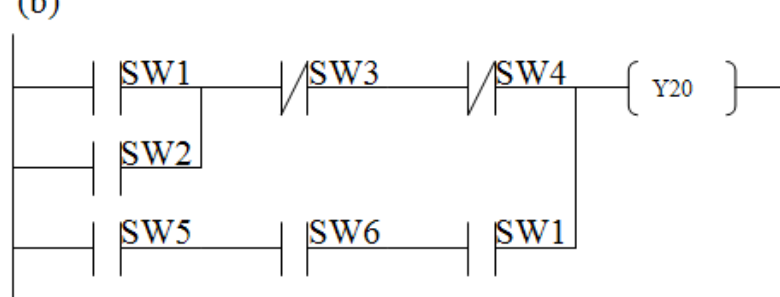

2.3) Develop a relay ladder logic that will switch on the motor on/off in automatic and manual (called jog) modes?

(ans: SW1: START push bottom, SW3 STOP push bottom, SW2 JOG or Manual operating mode, and Y20 memory that will run the relay that will switch the motor on)

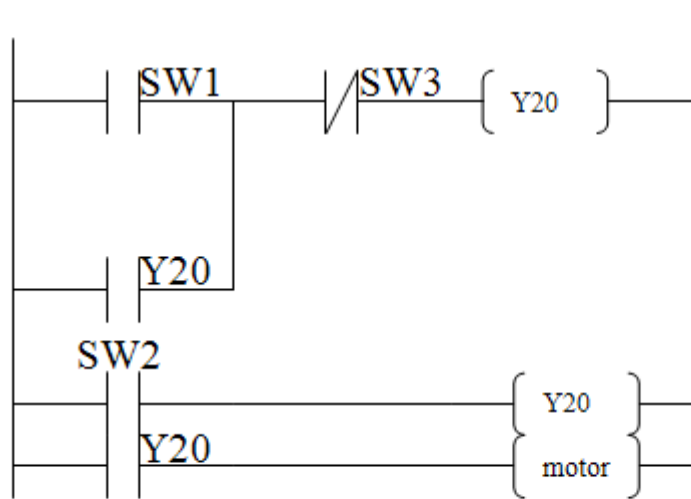

2.4) Give examples of where a *PLC* could be used?

2.5) Why would relays be used in place of *PLC*?

(ans: for some cases is simple and cost effective)

2.6) List the advantages of a *PLC* over relay control?